

HOSPIRA

TECHNICAL SUPPORT OPERATIONS
ELECTRONIC TECHNICAL SERVICE MANUAL

Plum XL Series Infusion Systems

EPS-00587-008 (REV. 2/05)



PLUM XLTM Series Infusion Systems

For use with the following list numbers:

| | |
|---|---|
| Plum XL | 11555-04, 12570-04 |
| LifeCare XL | 11555-09, 11555-13, 11555-27, 11555-29, 11555-36, 11555-46, 11555-54, 11555-88 |
| Plum XLM | 11846-04 |
| LifeCare XLM | 11846-09, 11846-27, 11846-29, 11846-36, 11846-42, 11846-46, 11846-54, 11846-88 |
| Plum XLM with DataPort | 11859-04 |
| Plum XLM with DataPort Veterinary | 12570-04 |
| LifeCare XLM with DataPort | 11859-09, 11859-27, 11859-29, 11859-36, 11859-42, 11859-54, 11859-63, 11859-69, 11859-71, 11859-88 |

Technical Service Manual



© 2005

Hospira, Inc.

This document and the subject matter disclosed herein are proprietary information. Hospira retains all the exclusive rights of dissemination, reproduction, manufacture, and sale. Any party using this document accepts it in confidence, and agrees not to duplicate it in whole or in part nor disclose it to others without the written consent of Hospira.

Change History

| Part Number | Description of Change | Remove and Destroy Pages | Insert Change Pages |
|----------------------------|---|---------------------------------|----------------------------|
| 430-00587-001 (Rev. 11/93) | Original issue | | |
| 430-00587-002 (Rev. 7/94) | Second issue | | |
| 430-00587-A02 (Rev. 11/94) | Updated cover | Cover | Cover |
| | Updated Change History | i, ii | i, ii |
| | Added error code 59-1 to Table 6-2 | 6-7 to 6-10 | 6-7 to 6-10 |
| 430-00587-003 (Rev. 2/96) | Third issue | | |
| 430-00587-004 (Rev. 12/97) | Fourth issue | | |
| 430-00587-005 (Rev. 2/99) | Fifth issue | | |
| | Updated Table 5-1 | | |
| | Included international DataPort content | | |
| 430-00587-006 (Rev. 10/99) | Sixth issue | | |
| | Included nurse call adapter information | | |
| 430-00587-007 (Rev. 08/01) | Seventh issue | | |
| | Updated PVT in Section 5 | | |
| | Updated replacement procedures in Section 7 | | |
| | Updated IPB graphics in Section 9 | | |
| 430-00587-008 (Rev. 2/05) | Eighth issue | | |
| | Incorporated Hospira name change | | |
| | Included IEC 60601-1-2 specifications in Appendix and throughout manual | | |
| | Updated replacement procedures in Section 7 | | |
| | Updated IPB graphics in Section 9 | | |

This page intentionally left blank.

Contents

Section 1

| | |
|---|-----|
| INTRODUCTION | 1-1 |
| 1.1 SCOPE | 1-1 |
| 1.2 GLOBAL PRODUCT CONFIGURATIONS | 1-2 |
| 1.3 CONVENTIONS. | 1-5 |
| 1.4 COMPONENT DESIGNATORS | 1-6 |
| 1.5 ACRONYMS AND ABBREVIATIONS. | 1-6 |
| 1.6 USER QUALIFICATION | 1-7 |
| 1.7 ARTIFACTS | 1-8 |
| 1.8 INSTRUMENT INSTALLATION PROCEDURE | 1-8 |
| 1.8.1 UNPACKING | 1-8 |
| 1.8.2 INSPECTION | 1-9 |
| 1.8.3 SELF TEST. | 1-9 |

Section 2

| | |
|--------------------|-----|
| WARRANTY | 2-1 |
|--------------------|-----|

Section 3

| | |
|-----------------------------------|-----|
| SYSTEM OPERATING MANUAL | 3-1 |
|-----------------------------------|-----|

Section 4

| | |
|---|------|
| THEORY OF OPERATION | 4-1 |
| 4.1 GENERAL DESCRIPTION | 4-1 |
| 4.2 ELECTRONICS OVERVIEW | 4-2 |
| 4.2.1 POWER SUPPLY PWA | 4-2 |
| 4.2.1.1 SWITCHER CIRCUITRY | 4-2 |
| 4.2.1.2 VOLTAGE REGULATOR CIRCUITRY | 4-3 |
| 4.2.1.3 BATTERY CHARGER CIRCUITRY | 4-4 |
| 4.2.2 POWER SUPPLY PWA | 4-5 |
| 4.2.2.1 SWITCHER CIRCUITRY | 4-5 |
| 4.2.2.2 VOLTAGE REGULATOR CIRCUITRY | 4-6 |
| 4.2.2.3 BATTERY CHARGER CIRCUITRY | 4-6 |
| 4.2.3 MCU PWA. | 4-7 |
| 4.2.3.1 WATCHDOG CIRCUITRY | 4-7 |
| 4.2.3.2 SERIAL COMMUNICATION CIRCUITRY | 4-7 |
| 4.2.3.3 ALARM CIRCUITRY (XL) | 4-8 |
| 4.2.3.4 ALARM CIRCUITRY (XLM) | 4-8 |
| 4.2.3.5 ALARM POWER BACKUP CIRCUITRY | 4-8 |
| 4.2.3.6 MOTOR DRIVER CIRCUITRY | 4-9 |
| 4.2.3.7 PIN DETECTOR CIRCUITRY | 4-9 |
| 4.2.3.8 UART (XLM WITH DATAPORT) | 4-9 |
| 4.2.3.9 NURSE CALL ALARM (XLM WITH DATAPORT - NURSE CALL) | 4-10 |
| 4.2.4 BUZZER PWA (XLM) | 4-10 |
| 4.2.4.1 HIGH VOLUME AUDIBLE ALARM | 4-10 |
| 4.2.4.2 LOCKOUT SWITCH | 4-11 |
| 4.2.5 DISPLAY PWA | 4-11 |
| 4.2.5.1 DISPLAY CIRCUITRY (XL) | 4-11 |
| 4.2.5.2 DISPLAY CIRCUITRY (XLM DISPLAY PWA -003 AND LOWER) | 4-11 |

| | | |
|---------|--|------|
| 4.2.5.3 | DISPLAY CIRCUITRY (XLM DISPLAY PWA -004 AND HIGHER) | 4-11 |
| 4.2.5.4 | EL PANEL DRIVER CIRCUITRY (XL) | 4-12 |
| 4.2.5.5 | LED BACKLIGHT PANEL AND DRIVER (XLM) | 4-12 |
| 4.2.5.6 | RUN INDICATOR CIRCUITRY. | 4-12 |
| 4.2.5.7 | LINE POWER INDICATOR CIRCUITRY | 4-12 |
| 4.2.5.8 | CONTROL KNOB CIRCUITRY (XL) | 4-13 |
| 4.2.5.9 | CONTROL KNOB CIRCUITRY (XLM) | 4-13 |
| 4.2.6 | SENSOR PWA | 4-13 |
| 4.2.6.1 | PRESSURE AMPLIFIER/FILTER CIRCUITRY. | 4-13 |
| 4.2.6.2 | AC AMPLIFIER CIRCUITRY. | 4-14 |
| 4.2.6.3 | VOLTAGE REFERENCE CIRCUITRY | 4-14 |
| 4.2.6.4 | OPTO INTERRUPTER CIRCUITRY | 4-14 |
| 4.2.6.5 | EEPROM CIRCUITRY | 4-14 |
| 4.2.7 | BUBBLE SENSOR PWA | 4-14 |
| 4.2.7.1 | TRANSMITTER CIRCUITRY | 4-15 |
| 4.2.7.2 | RECEIVER CIRCUITRY | 4-15 |
| 4.2.7.3 | PIN DETECTOR FLEX CIRCUITRY | 4-15 |
| 4.3 | MECHANICAL OVERVIEW | 4-16 |
| 4.3.1 | CASSETTE | 4-16 |
| 4.3.2 | MECHANISM ASSEMBLY | 4-18 |
| 4.3.2.1 | MOTOR AND VALVE ASSEMBLIES. | 4-19 |
| 4.3.2.2 | PRIMARY/SECONDARY VALVE SUBSYSTEM | 4-19 |
| 4.3.2.3 | INLET/OUTLET VALVE SUBSYSTEM | 4-20 |
| 4.3.2.4 | PLUNGER DRIVE SUBSYSTEM | 4-20 |

Section 5

| | |
|--|------|
| MAINTENANCE AND SERVICE TESTS | 5-1 |
| 5.1 ROUTINE MAINTENANCE | 5-1 |
| 5.1.1 INSPECTING THE INFUSION SYSTEM. | 5-1 |
| 5.1.2 CLEANING THE INFUSION SYSTEM | 5-1 |
| 5.1.3 SANITIZING THE INFUSION SYSTEM. | 5-2 |
| 5.1.4 CLEANING THE BUZZER | 5-3 |
| 5.2 PERFORMANCE VERIFICATION TEST | 5-4 |
| 5.2.1 EQUIPMENT REQUIRED | 5-4 |
| 5.2.2 ICONS AND ENGLISH LANGUAGE EQUIVALENTS | 5-5 |
| 5.2.3 INSPECTION | 5-6 |
| 5.2.4 TEST SETUP. | 5-6 |
| 5.2.5 SELF TEST | 5-7 |
| 5.2.6 KEYPAD AND CONTROL KNOB TEST. | 5-8 |
| 5.2.7 OPEN DOOR ALARM TEST | 5-9 |
| 5.2.8 ALARM LOUDNESS TEST (XL). | 5-9 |
| 5.2.9 ALARM LOUDNESS AND LOCK FUNCTION TESTS (XLM) | 5-9 |
| 5.2.10 BATTERY LEGEND TEST | 5-10 |
| 5.2.11 FREE FLOW TEST. | 5-10 |
| 5.2.12 PROXIMAL OCCLUSION TEST. | 5-10 |
| 5.2.13 DISTAL OCCLUSION TEST | 5-11 |
| 5.2.14 DELIVERY ACCURACY TEST | 5-12 |
| 5.2.15 EMPTY CONTAINER/AIR-IN-LINE ALARM TEST. | 5-12 |
| 5.2.16 ELECTRICAL SAFETY TEST | 5-13 |
| 5.2.17 END OF PERFORMANCE VERIFICATION TEST | 5-14 |
| 5.3 PERIODIC MAINTENANCE INSPECTION | 5-14 |
| 5.4 BATTERY OPERATION OVERVIEW | 5-14 |
| 5.4.1 BATTERY CHARGER CURRENT TEST (OPTIONAL). | 5-15 |
| 5.5 DATAPORT CONNECTION AND GROUND CONTINUITY TEST (OPTIONAL) | 5-16 |
| 5.6 NURSE CALL FUNCTION TEST (OPTIONAL). | 5-18 |

Section 6

| | |
|--|------|
| TRUBLESHOOTING | 6-1 |
| 6.1 TECHNICAL ASSISTANCE. | 6-1 |
| 6.2 ALARM MESSAGES AND ERROR CODES | 6-1 |
| 6.2.1 OPERATIONAL ALARM MESSAGES | 6-2 |
| 6.2.2 ERROR CODES REQUIRING TECHNICAL SERVICE | 6-6 |
| 6.2.3 SERVICE MODE | 6-11 |
| 6.2.3.1 ALARM HISTORY | 6-11 |
| 6.2.3.2 SOFTWARE REVISION NUMBER. | 6-12 |
| 6.2.3.3 RUN TIME AND BATTERY RUN TIME | 6-12 |
| 6.2.3.4 PARAMETER PROGRAMMING (XLM WITH DATAPORT) | 6-12 |
| 6.3 TROUBLESHOOTING PROCEDURES. | 6-14 |

Section 7

| | |
|--|------|
| REPLACEABLE PARTS AND REPAIRS | 7-1 |
| 7.1 REPLACEABLE PARTS | 7-1 |
| 7.2 REPLACEMENT PROCEDURES | 7-3 |
| 7.2.1 SAFETY AND EQUIPMENT PRECAUTIONS | 7-3 |
| 7.2.2 REQUIRED TOOLS AND MATERIALS | 7-3 |
| 7.2.3 RUBBER FOOT PAD REPLACEMENT | 7-4 |
| 7.2.4 BATTERY WITH WIRE HARNESS ASSEMBLY, BATTERY DOOR, AND BATTERY DOOR PAD REPLACEMENT. | 7-6 |
| 7.2.5 SEPARATING THE FRONT ENCLOSURE ASSEMBLY, REAR ENCLOSURE ASSEMBLY, AND MAIN CHASSIS ASSEMBLY | 7-7 |
| 7.2.6 FRONT ENCLOSURE ASSEMBLY, REAR ENCLOSURE ASSEMBLY, OR MAIN CHASSIS ASSEMBLY REPLACEMENT | 7-9 |
| 7.2.7 FRONT ENCLOSURE ASSEMBLY COMPONENT REPLACEMENT. | 7-10 |
| 7.2.7.1 DISPLAY PWA AND MCU/DISPLAY CABLE REPLACEMENT | 7-11 |
| 7.2.7.2 FRONT PANEL KEY REPLACEMENT | 7-12 |
| 7.2.7.3 CONTROL KNOB, KNOB DETENT, WASHER, GASKET, SNAP RETAINER, AND DETENT RING REPLACEMENT | 7-13 |
| 7.2.7.4 FRONT PANEL LABEL REPLACEMENT | 7-14 |
| 7.2.8 REAR ENCLOSURE ASSEMBLY COMPONENT REPLACEMENT | 7-14 |
| 7.2.8.1 FUSE REPLACEMENT | 7-15 |
| 7.2.8.2 POWER SUPPLY PWA REPLACEMENT. | 7-17 |
| 7.2.8.3 VELCRO RETAINER STRAP REPLACEMENT | 7-19 |
| 7.2.8.4 AC (MAINS) POWER CORD AND STRAIN RELIEF BUSHING REPLACEMENT | 7-19 |
| 7.2.8.5 AC (MAINS) POWER CORD REPLACEMENT (INTERNATIONAL) | 7-21 |
| 7.2.8.6 AC RECEPTACLE, EMI SHIELD, AND EQUIPOTENTIAL POST REPLACEMENT | 7-22 |
| 7.2.8.7 LIFECARE AC RECEPTACLE, BRACKET, GASKET, SEAL, AND EQUIPOTENTIAL POST REPLACEMENT | 7-23 |
| 7.2.8.8 DATAPORT/MCU CABLE ASSEMBLY REPLACEMENT (XLM WITH DATAPORT) | 7-25 |
| 7.2.8.9 LIFECARE DATAPORT/MCU CABLE ASSEMBLY REPLACEMENT (XLM WITH DATAPORT) | 7-27 |
| 7.2.8.10 POLE CLAMP EXTRUSION, POLE CLAMP BACKING PLATE, AND ADHESIVE-BACKED INSULATOR REPLACEMENT. | 7-28 |
| 7.2.8.11 POLE CLAMP SHAFT/KNOB ASSEMBLY AND POLE CLAMP SHAFT TIP REPLACEMENT | 7-30 |
| 7.2.8.12 BUZZER PWA AND MCU/BUZZER CABLE REPLACEMENT | 7-31 |

7.2.9 MAIN CHASSIS ASSEMBLY COMPONENT REPLACEMENT 7-32

7.2.9.1 MCU PWA AND SENSOR/MCU CABLE ASSEMBLY
REPLACEMENT 7-33

7.2.9.2 MECHANISM ASSEMBLY REPLACEMENT 7-35

7.2.9.3 CASSETTE DOOR AND MECHANISM SHIELD
REPLACEMENT 7-36

7.2.9.4 OPENER HANDLE ASSEMBLY REPLACEMENT 7-41

Section 8

SPECIFICATIONS 8-1

8.1 PLUM XL AND XLM 8-1

8.2 LIFECARE XL AND XLM 8-2

Section 9

DRAWINGS 9-1

Appendix A-1

Index. I-1

Figures

| | | |
|--------------|--|------|
| Figure 1-1. | Plum XL Icon Based and English Language Front Panels | 1-4 |
| Figure 1-2. | Plum XLM Icon Based and English Language Front Panels | 1-4 |
| Figure 1-3. | Plum XL LCD Test Screens | 1-10 |
| Figure 1-4. | Plum XLM LCD Test Screens. | 1-10 |
| Figure 4-1. | Major Elements of the Dual-Channel Cassette. | 4-17 |
| Figure 4-2. | Fluid Path in the Cassette | 4-18 |
| Figure 4-3. | Mechanism Valve Pins and Sensor Locations | 4-20 |
| Figure 5-1. | Cleaning the Buzzer | 5-3 |
| Figure 5-2. | Icons and English Language Equivalents | 5-5 |
| Figure 5-3. | Plum XL LCD Test Screens | 5-7 |
| Figure 5-4. | Plum XLM LCD Test Screens. | 5-8 |
| Figure 5-5. | Distal Occlusion Test Setup | 5-11 |
| Figure 5-6. | Special Cassettes with Bubble Sensor Tips Removed | 5-13 |
| Figure 5-7. | Battery Charger Current Test Configuration | 5-16 |
| Figure 5-8. | DataPort Connector | 5-17 |
| Figure 7-1. | Bottom View of the Infusion System | 7-5 |
| Figure 7-2. | Front Enclosure, Main Chassis Assembly, and Rear Enclosure | 7-8 |
| Figure 7-3. | Display PWA and MCU/Display Cable | 7-10 |
| Figure 7-4. | Front Enclosure Assembly Components | 7-11 |
| Figure 7-5. | Fuse Replacement (115 VAC). | 7-16 |
| Figure 7-6. | Fuse Replacement (220 VAC). | 7-16 |
| Figure 7-7. | Power Supply PWA | 7-18 |
| Figure 7-8. | AC Power Cord (115 VAC - Plum XL) | 7-20 |
| Figure 7-9. | AC Power Cord (115 VAC - Plum XLM) | 7-21 |
| Figure 7-10. | AC Power Cord (220 VAC - Plum XLM) | 7-23 |
| Figure 7-11. | AC Power Cord (220 VAC - Plum XLM) | 7-24 |
| Figure 7-12. | DataPort Assembly (Domestic) | 7-26 |
| Figure 7-13. | DataPort Assembly (International). | 7-28 |
| Figure 7-14. | XL Series Pole Clamp | 7-30 |
| Figure 7-15. | Buzzer PWA. | 7-32 |
| Figure 7-16. | Exploded View of the Main Chassis Assembly | 7-34 |
| Figure 7-17. | Top View of the Main Chassis Assembly | 7-35 |
| Figure 7-18. | Mechanism Shield Replacement | 7-38 |
| Figure 7-19. | Cassette Door Replacement (1 of 3). | 7-39 |
| Figure 7-20. | Cassette Door Replacement (2 of 3). | 7-39 |
| Figure 7-21. | Cassette Door Replacement (3 of 3) | 7-40 |
| Figure 7-22. | Cassette Door Replacement, Bottom View | 7-40 |
| Figure 7-23. | Opener Handle Assembly Replacement (1 of 3) | 7-42 |
| Figure 7-24. | Opener Handle Assembly Replacement (2 of 3) | 7-43 |
| Figure 7-25. | Opener Handle Assembly Replacement (3 of 3) | 7-43 |
| Figure 9-1. | Illustrated Parts Breakdown | 9-7 |
| Figure 9-2. | Front Enclosure, Rear Enclosure, and Main Chassis Assemblies | 9-11 |
| Figure 9-3. | Front Enclosure Assembly | 9-13 |
| Figure 9-4. | Rear Enclosure Assembly (XL Domestic). | 9-15 |
| Figure 9-5. | Rear Enclosure Assembly (XL International) | 9-17 |
| Figure 9-6. | Rear Enclosure Assembly (XLM Domestic) | 9-19 |
| Figure 9-7. | Rear Enclosure Assembly (XLM International) | 9-21 |
| Figure 9-8. | Rear Enclosure Assembly (XLM with DataPort - Domestic) | 9-23 |
| Figure 9-9. | Rear Enclosure Assembly (XLM with DataPort - International) | 9-25 |
| Figure 9-10. | Rear Enclosure Assembly (Lifecare XLM with DataPort) | 9-27 |
| Figure 9-11. | Main Chassis Assembly. | 9-29 |
| Figure 9-12. | Battery Replacement | 9-31 |
| Figure 9-13. | Mechanical Assembly | 9-33 |

Figure 9-14. Plum XL Block Diagram 9-37

Figure 9-15. MCU PWA Schematic (XL) 9-39

Figure 9-16. MCU PWA Schematic (XLM) 9-43

Figure 9-17. MCU PWA Schematic (XLM with DataPort) 9-47

Figure 9-18. Display PWA Schematic (XL) 9-83

Figure 9-19. Display PWA Schematic (XLM) 9-85

Figure 9-20. Bubble Sensor PWA Schematic 9-99

Figure 9-21. Sensor PWA Schematic 9-105

Figure 9-22. Pin Detector Flex Circuit Schematic 9-107

Figure 9-23. Power Supply PWA Schematic (XL Domestic) 9-109

Figure 9-24. Power Supply PWA Schematic (XL International) 9-113

Figure 9-25. Power Supply PWA Schematic (XLM Domestic) 9-117

Figure 9-26. Power Supply PWA Schematic (XLM International) 9-121

Figure 9-27. Power Supply PWA Schematic (XLM with DataPort) 9-129

Figure 9-28. Buzzer PWA Schematic 9-137

Tables

Table 1-1. Global Product Configurations 1-2

Table 1-2. Conventions 1-5

Table 4-1. Battery Charge Current States 4-4

Table 5-1. Cleaning Solutions 5-2

Table 5-2. Battery Charger Current Test Parameters 5-16

Table 6-1. Operational Alarm Messages and Corrective Actions 6-2

Table 6-2. Error Codes Requiring Technical Service 6-6

Table 6-3. Service Mode Control Knob Settings 6-11

Table 6-4. Sub-Modes of Parameter Programming 6-12

Table 6-5. Communication Circuitry Selections 6-13

Table 6-6. PVT Troubleshooting 6-14

Table 7-1. Wire Color Coding 7-18

Table 9-1. Drawings 9-1

Table 9-2. IPB for the Infusion System 9-2

Table A-1. Guidance and Manufacturer’s Declaration - Electromagnetic Emissions A-1

Table A-2. Guidance and Manufacturer’s Declaration - Electromagnetic Immunity A-2

Table A-3. Guidance and Manufacturer’s Declaration - Electromagnetic Immunity for Life-Supporting Equipment and Systems A-3

Table A-4. Recommended Separation Distances Between Portable and Mobile RF Communications Equipment and the LifeCare XLM with DataPort A-5

Section 1

INTRODUCTION

The Plum XL™, XL Micro/Macro, and XL Micro/Macro with DataPort Infusion Systems are dual-line volumetric infusion systems designed to meet the growing demand for hospital-wide device standardization. The infusion system provides primary line, secondary line, and piggyback fluid delivery capabilities to furnish a wide range of general floor, critical care, and home care applications. Compatibility with LifeCare® 5000 PlumSet® administration sets and accessories make the infusion system convenient and cost-effective. The Plum XL Micro/Macro is herein referred to as XLM. The Plum XL Micro/Macro with DataPort is herein referred to as Plum XLM with DataPort.

- ✎ **Note:** References to the Plum XL and XLM Infusion Systems apply to the LifeCare XL and XLM Infusion Systems as well.
- ✎ **Note:** Unless otherwise stated, references to the Plum XLM include the Plum XLM with DataPort.
- ✎ **Note:** Do not connect DataPort when infusing.



1.1 SCOPE

This Technical Service Manual applies to Plum XL series infusion systems only. It is organized into the following sections:

- [Section 1 Introduction](#)
- [Section 2 Warranty](#)
- [Section 3 System Operating Manual](#)
- [Section 4 Theory of Operation](#)
- [Section 5 Maintenance and Service Tests](#)
- [Section 6 Troubleshooting](#)
- [Section 7 Replaceable Parts and Repair](#)
- [Section 8 Specifications](#)
- [Section 9 Drawings](#)
- [Appendices](#)
- [Index](#)
- [Technical Service Bulletins](#)

If a problem in device operation cannot be resolved using the information in this manual, contact Hospira (*see Section 6.1, Technical Assistance*).



Specific instructions for operating the device are contained in the *Plum XL System Operating Manual*, *Plum XL Micro/Macro System Operating Manual*, and *Plum XL Micro/Macro with DataPort System Operating Manual*. Provision is made for the inclusion of the system operating manual in *Section 3* of this manual.

- 
Note: In this manual, the terms “device” and “infusion system” refer to all configurations of the Plum XL series infusion system unless otherwise specified. Display messages and key labels may vary slightly, depending on the configuration of the infusion system in use.
- 
Note: Figures are rendered as graphic representations to approximate actual product; therefore, figures may not exactly reflect the product.

1.2

GLOBAL PRODUCT CONFIGURATIONS

The design of the infusion system facilitates its operation in many countries with slight modification to the product. Three configurations presented in this manual are detailed in *Table 1-1, Global Product Configurations*. The front panels of the English language and icon based system are shown in *Figure 1-1, Plum XL Icon Based and English Language Front Panels* and *Figure 1-2, Plum XLM Icon Based and English Language Front Panels*.

| Group Icon | List Number | Country | Power Supply | Rear Case | LCD |
|---|--|-------------------------------|----------------|--|---------|
|  115V | 11555-04 11846-04 11859-04 12570-04 | USA | 100-130 VAC | Nondetachable AC (mains) power cord | English |
| | 11555-13 | French Canadian | 100-130 VAC | Nondetachable AC (mains) power cord | Icons |
| | 11555-88 11846-88 11859-88* | Spanish | | | |
|  220V | 11555-27 11846-27 11859-27* | Australia | 210-260 VAC | Detachable AC (mains) power cord | English |
| | 11555-54 11846-54 11859-54* | UK | | | |
| | 11555-09 11846-09 11859-09* | Spanish (Latin America) | 210-260 VAC | Detachable AC (mains) power cord | Icons |

| Table 1-1. Global Product Configurations | | | | | |
|--|-----------------------------------|----------------|--------------|-----------|-----|
| Group Icon | List Number | Country | Power Supply | Rear Case | LCD |
| | 11555-29 11846-29 11859-29* | French | | | |
| | 11555-36 11846-36 11859-36* | Europe | | | |
| | 11846-42 11859-42* | Italy | | | |
| | 11555-46 11846-46 | Swedish | | | |
| | 11859-63* | Poland | | | |
| | 11859-69* | Hungary | | | |
| | 11859-71* | Czech Republic | | | |

* Complies with IEC/EN 60601-1-2: 2001



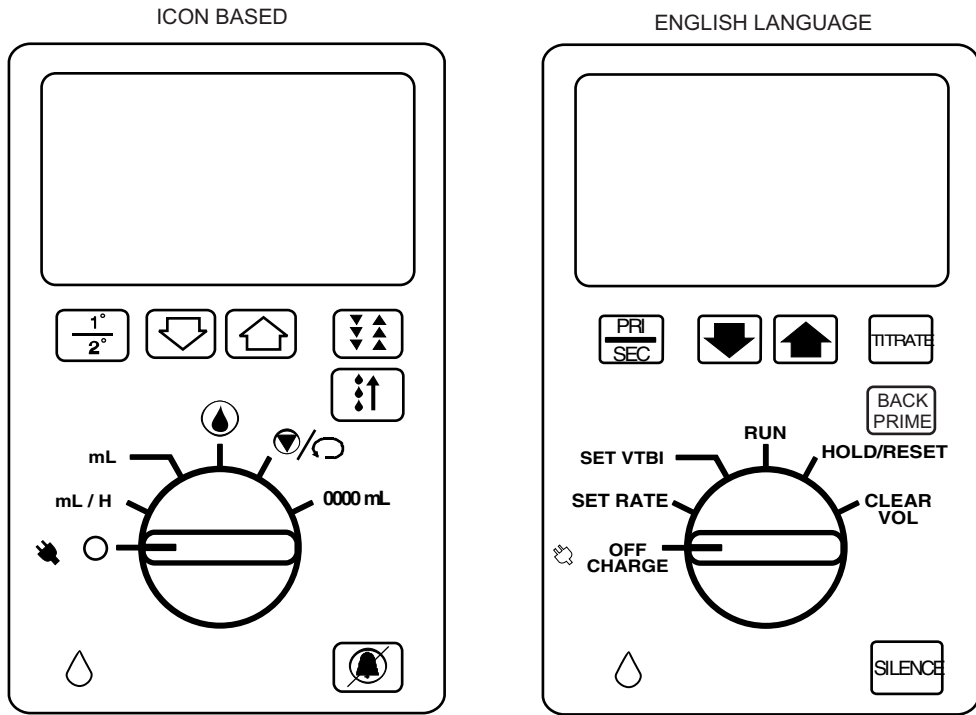

04K01021

Figure 1-1. Plum XL Icon Based and English Language Front Panels

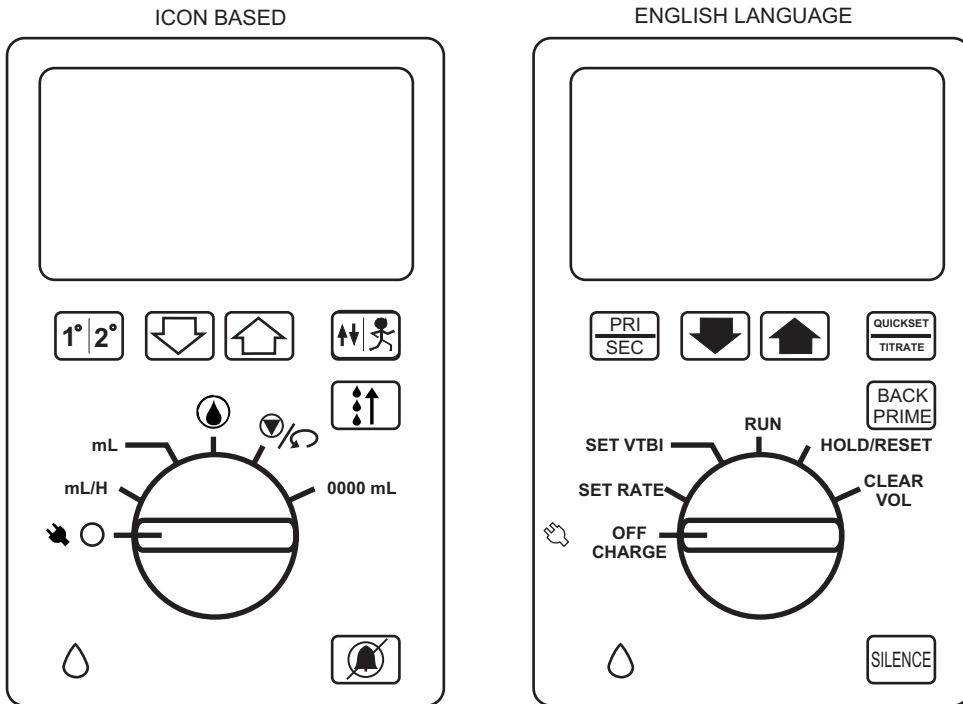

04K01022

Figure 1-2. Plum XLM Icon Based and English Language Front Panels

1.3 CONVENTIONS

The conventions listed in *Table 1-2, Conventions*, are used throughout this manual.

| Convention | Application | Example |
|---|---|---|
| <i>Italic</i> | Reference to a section, figure, table, or publication | <i>(see Figure 5-4, Distal Occlusion Test Setup)</i> |
| [ALL CAPS] | In-text references to keys are described in all caps and enclosed in brackets | [TITRATE] |
| ALL CAPS Initial Caps with lowercase | Screen displays | DOOR/CASSETTE Self test in progress |
| Bold | Emphasis | CAUTION: Use proper ESD grounding techniques when handling components. |

Throughout this manual, warnings, cautions and notes are used to emphasize important information.

WARNING: A WARNING CONTAINS SPECIAL SAFETY EMPHASIS AND MUST BE OBSERVED AT ALL TIMES. FAILURE TO OBSERVE A WARNING MAY RESULT IN PATIENT INJURY AND IS POTENTIALLY LIFE THREATENING.

CAUTION: A CAUTION usually appears in front of a procedure or statement. It contains information that could prevent hardware failure, irreversible damage to equipment or loss of data.

Note: A note highlights information to help clarify a concept, procedure or statement.

 **EN-2** : Information applies to IEC/EN 60601-1-2: 2001 compliant devices.

1.4

COMPONENT DESIGNATORS

Components are indicated by alpha-numeric designators, as follows:

| | | | | | |
|-----------|-----------|--------------------|----------|------------|-----------|
| Battery | BT | Diode | D | Resistor | R |
| Capacitor | C | Fuse | F | Switch | SW |
| Crystal | Y | Integrated Circuit | U | Transistor | Q |

The number following the letter is a unique value for each type of component (e.g., R1, R2).

 **Note:** Alpha-numeric designators may be followed with a dash (-) number that indicates a pin number for that component. For example, U15-13 is pin 13 of the encoder chip [U15] on the interface PWA.

1.5

ACRONYMS AND ABBREVIATIONS

Acronyms and abbreviations used in this manual are as follows:

| | |
|---------------|---|
| A | Ampere |
| AC | Alternating current |
| ACE | Asynchronous communication element |
| AC RMS | Alternating current root mean square |
| A/D | Analog-to-digital |
| CMOS | Complementary metal-oxide semiconductor |
| CPU | Central processing unit |
| DC | Direct current |
| DMM | Digital multimeter |
| DPM | Digital pressure meter |
| ECG | Electrocardiograph |
| EEG | Electroencephalogram |
| EEPROM | Electrically erasable programmable read-only memory |
| EL | Electroluminescent |
| EMG | Electromyogram |
| EMI | Electromagnetic interference |
| ETO | Ethylene oxide |
| FET | Field-effect transistor |
| HKDC | Housekeeping DC |
| hr | Hour |
| Hz | Hertz |
| IC | Integrated circuit |

| | |
|---------------|---|
| IEC | International Electrotechnical Commission |
| IPB | Illustrated parts breakdown |
| IV | Intravenous |
| kHz | Kilohertz |
| KVO | Keep vein open |
| LCD | Liquid crystal display |
| LED | Light-emitting diode |
| mA | Milliampere |
| MCU | Micro controller unit |
| MHz | Megahertz |
| mL | Milliliter |
| mV | Millivolt |
| PLL | Phase-lock loop |
| PVT | Performance verification test |
| PSI | Pounds per square inch |
| PWA | Printed wiring assembly |
| SPSTIN | Single-pole, single-throw in |
| UART | Universal asynchronous receiver/transmitter |
| VAC | Volts AC |
| VCO | Voltage-controlled oscillator |
| VCC | Collector supply voltage |
| VDC | Volts DC |
| VDIG | Digital voltage |
| VMOT | Motor voltage |
| Vpp | Volts peak-to-peak |
| VTBI | Volume to be infused |
| μA | Microampere |
| μL | microliter |
| μS | microsecond |

1.6

USER QUALIFICATION

The Plum XL series infusion system is for use at the direction or under the supervision of licensed physicians or certified healthcare professionals who are trained in the use of the infusion system and the administration of parenteral and enteral fluids and drugs, and whole blood or red blood cell components. Training should emphasize preventing related IV complications, including appropriate precautions to prevent accidental infusion of air. The epidural route can be used to provide anesthesia or analgesia.

1.7 ARTIFACTS

Nonhazardous, low-level electrical potentials are commonly observed when fluids are administered using infusion devices. These potentials are well within accepted safety standards, but may create artifacts on voltage-sensing equipment such as ECG, EMG, and EEG machines. These artifacts vary at a rate that is associated with the infusion rate. If the monitoring machine is not operating correctly or has loose or defective connections to its sensing electrodes, these artifacts may be accentuated so as to simulate actual physiological signals. To determine if the abnormality in the monitoring equipment is caused by the infuser instead of some other source in the environment, set the infuser so that it is temporarily not delivering fluid. Disappearance of the abnormality indicates that it was probably caused by electronic noise generated by the infuser. Proper setup and maintenance of the monitoring equipment should eliminate the artifact. Refer to the appropriate monitoring system documentation for setup and maintenance instructions.

1.8 INSTRUMENT INSTALLATION PROCEDURE

CAUTION: Infusion system damage may occur unless proper care is exercised during product unpacking and installation. The battery may not be fully charged upon receipt of the infusion system. Do not place the infusion system in service if it fails the self test.

CAUTION: Infusion system performance may be degraded by electromagnetic interference (EMI) from devices such as electrosurgical units, cellular phones, and two-way radios. Operation of the infusion system under such conditions should be avoided.

CAUTION: Before operating the infusion system next to, or in a stacked configuration with other electrical equipment, confirm the infusion system's operational performance in that configuration.

CAUTION: The use of any accessory, transducer or cable with the LifeCare XLM with DataPort other than those specified may result in increased emissions or decreased immunity of the LifeCare XLM with DataPort.

The instrument installation procedure consists of unpacking, inspecting, and self test.

Note: Do not place the infusion system in service if the battery is not fully charged. To make certain the battery is fully charged, connect the infusion system to AC (mains) power for eight hours (*see Section 8, Specifications*).

1.8.1 UNPACKING

Inspect the infusion system shipping container as detailed in *Section 1.8.2, Inspection*. Use care when unpacking the infusion system. Retain the packing slip and save all packing materials in the event it is necessary to return the infusion system to the factory. Verify that the shipping container includes a copy of the system operating manual.

1.8.2

INSPECTION

Inspect the infusion system for shipping damage. Should any damage be found, contact the delivering carrier immediately.

CAUTION: Do not use the infusion system if it appears to be damaged. Should damage be found, contact Hospira (see Section 6.1, Technical Assistance). Do not use the infusion system if it appears to be damaged.

Inspect the infusion system periodically for signs of defects such as worn accessories, broken connections, or damaged cable assemblies. Also inspect the infusion system after repair or during cleaning. Replace any damaged or defective external parts.

1.8.3

SELF TEST

CAUTION: Do not place the infusion system in service if the self test fails.

To perform the self test, refer to [Figure 1-3, Plum XL LCD Test Screens](#) and [Figure 1-4, Plum XLM LCD Test Screens](#), and proceed as follows:

1. Connect the infusion system AC (mains) power cord to a grounded AC (mains) outlet and confirm the AC (mains) power icon (next to the OFF/CHARGE setting) illuminates.
2. Open the door assembly (cassette door) by lifting up on the cassette door handle.
3. Hold a primed cassette by its handle and insert the cassette into the cassette door guides. Do not force the cassette into position.
4. Close the cassette door handle to lock the cassette in place.
5. Turn the control knob to SET RATE to initiate the self test.
6. Verify the following screens display in succession:
 - LCD test screen
 - Four backward Cs (approximately two seconds)
 - Set rate screen
7. Disconnect the infusion system from AC (mains) power and confirm BATTERY displays on the LCD screen.
8. Turn the control knob to OFF/CHARGE and remove the administration set.
9. To allow the battery to charge fully, connect the infusion system to AC (mains) power for a minimum of eight hours with the control knob in the OFF/CHARGE position. Confirm the AC (mains) power icon illuminates.

- Note:** If the LCD test screen does not match *Figure 1-3* or *Figure 1-4* exactly, [contact Hospira](#).
- Note:** If an alarm condition occurs during the self test, cycle the power and repeat the self test. If the alarm condition recurs, note the message and take corrective action (*see Section 6, Troubleshooting*). If the alarm condition continues to recur, remove the infusion system from service and contact Hospira.

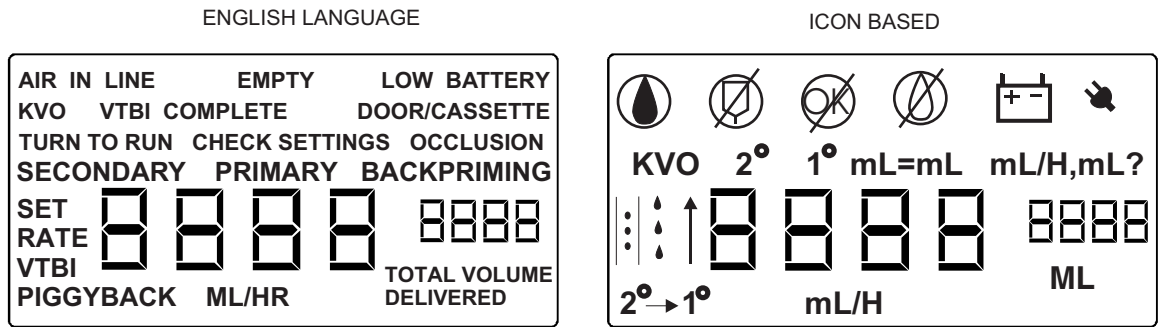

04K01024

Figure 1-3. Plum XL LCD Test Screens

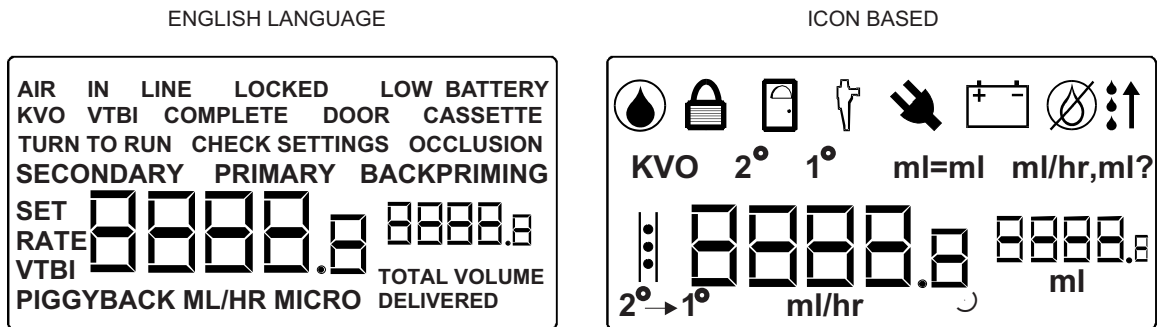

04K01025

Figure 1-4. Plum XLM LCD Test Screens

- Note:** All LCD screens on international infusion systems are icon-based, with the exceptions of country codes 27 and 54.

Section 2

WARRANTY

Subject to the terms and conditions herein, Hospira, Inc., herein referred to as Hospira, warrants that (a) the product shall conform to Hospira's standard specifications and be free from defects in material and workmanship under normal use and service for a period of one year after purchase, and (b) the replaceable battery shall be free from defects in material and workmanship under normal use and service for a period of 90 days after purchase. Hospira makes no other warranties, express or implied, as to merchantability, fitness for a particular purpose, or any other matter.

Purchaser's exclusive remedy shall be, at Hospira's option, the repair or replacement of the product. In no event shall Hospira's liability arising out of any cause whatsoever (whether such cause be based in contract, negligence, strict liability, other tort, or otherwise) exceed the price of such product, and in no event shall Hospira be liable for incidental, consequential, or special damages or losses or for lost business, revenues, or profits. Warranty product returned to Hospira must be properly packaged and sent freight prepaid.

The foregoing warranty shall be void in the event the product has been misused, damaged, altered, or used other than in accordance with product manuals so as, in Hospira's judgment, to affect its stability or reliability, or in the event the serial or lot number has been altered, effaced, or removed.

The foregoing warranty shall also be void in the event any person, including the Purchaser, performs or attempts to perform any major repair or other service on the product without having been trained by an authorized representative of Hospira and using Hospira documentation and approved spare parts. For purposes of the preceding sentence, "major repair or other service" means any repair or service other than the replacement of accessory items such as batteries, flow detectors, detachable AC power cords, and patient pendants.

In providing any parts for repair or service of the product, Hospira shall have no responsibility or liability for the actions or inactions of the person performing such repair or service, regardless of whether such person has been trained to perform such repair or service. It is understood and acknowledged that any person other than a Hospira representative performing repair or service is not an authorized agent of Hospira.

This page intentionally left blank.



Section 3

SYSTEM OPERATING MANUAL

A copy of the system operating manual is included with every infusion system. Insert a copy here for convenient reference. If a copy of the system operating manual is not available, [contact Hospira Technical Support Operations \(see Section 6.1, Technical Assistance\)](#).

This page intentionally left blank.

Section 4

THEORY OF OPERATION

This section describes the infusion system theory of operation. Related drawings are provided in [Section 9, Drawings](#). The theory of operation details the infusion system general description, electronics overview for both 115 VAC and 220 VAC systems, and mechanical overview of the system.

4.1

GENERAL DESCRIPTION

The infusion system includes the following features:

- Volume to be infused (VTBI) setting
- Safeguards to protect against overdelivery:
 - Motor speed is continuously monitored
 - Firmware senses malfunctions that could result in gravity flow
- Volume infused accumulation displays for primary and secondary solutions
- Flow rate selection from 1 to 999 mL/hr in 1 mL increments (XL)
- Flow rate selection from 0 to 99.9 mL in 0.1 mL/hr increments and 100 to 999 mL/hr in 1 mL increments (XLM)
- Battery operation
- Self test
- Simple setup (one hand cassette loading)
- Automatic memory retention of all previous therapy settings and fluid delivery data until cleared by user
- Alarms include the following:
 - OCCLUSION
 - AIR-IN-LINE
 - TURN TO RUN
 - LOW BATTERY
 - DOOR/CASSETTE (XL)
 - DOOR (XLM)
 - CASSETTE (XLM)
 - SET RATE
 - CHECK SETTINGS
 - VTBI COMPLETE
- Two-level adjustable alarm volume
- Remote monitoring with DataPort (XLM with DataPort)
- Nurse call alarm (XLM with DataPort - Nurse Call)

 **Note:** Do not connect DataPort when infusing.

 **Note:** Nurse call alarm is not available in IEC compliant infuser. 

4.2 ELECTRONICS OVERVIEW

This section describes the function and electronic circuitry of each printed wiring assembly (PWA) in the infusion system:

- Power supply PWA
- Micro controller unit (MCU) PWA
- Display PWA
- Buzzer PWA
- Sensor PWA
- Bubble sensor PWA

Schematic diagrams supporting the operation of infusion system PWAs are in [Section 9, Drawings](#).

4.2.1 POWER SUPPLY PWA



The power supply PWA provides direct current (DC) power to system circuits and charges the battery (*see Figure 9-23, Power Supply PWA Schematic (XL Domestic), Figure 9-25, Power Supply PWA Schematic (XLM Domestic) or Figure 9-27, Power Supply PWA Schematic (XLM with DataPort)*). The power supply PWA consists of switcher circuitry, voltage regulator circuitry, and battery charger circuitry. The following sections describe these circuits.

4.2.1.1 SWITCHER CIRCUITRY



The primary function of the switcher circuitry is to convert alternating current AC (mains) line power to an isolated +11 volts DC (VDC). Fuses F1 and F2, and variable resistor VR1 provide protection against AC (mains) line-high voltage spikes and excessive input power demands. Capacitors C1 and C2, transformer T1, and inductor L1 attenuate the conducted emissions. Bridge rectifier U1, resistor R1, and capacitor C3 provide the DC voltage required for switcher circuit. Diodes CR1 and CR2, R2, R3, CR4, C4, and C9 provide the supply voltage to the current mode-switcher controller integrated circuit (IC) U2. Transistor Q1, transformer T2, IC U2, and the associated passive components are enclosed in a shielded box to minimize radiated electromagnetic interference (EMI). U2 controls the duty cycle of Q1 through resistors R5 and R6. Resistor R9 provides current sensing. Resistor R8 and capacitor C7 filter the ramp voltage across R9 and feed it back to U2.

U2 configuration allows DC voltage at pin 9 (ERR+) to equal the peak voltage across resistor R9. DC voltage controls the delivered power through transformer T2 to regulate the output voltage. Voltage at U2-9 is limited to +1.25 VDC so that peak current through transistor Q1 is limited to approximately 2 amperes (A). This limit constitutes the output short protection.

Optocoupler U3 is part of the main regulation loop; it provides the UL-544 isolation barrier.

Resistor R61, diode CR5, and capacitor C6 provide protection from T2 windings short by applying the higher voltage across resistor R9 to the U2 inhibit input. C6 and the input impedance at U2-4 determine the low hiccup frequency in the event of a T2 winding short.

Diode CR3 and the clamp winding of transformer T2 provide intermediate energy transfer to capacitor C3 and limit the peak voltage across transistor Q1. At AC (mains) power-up, capacitor C12 provides delayed timing to permit the voltage potential at U2-14 (Vcc) to reach its minimum level.

Diode CR11 and capacitors C23 and C24 rectify the transformer T2 voltage to create the main DC voltage source (+BUSS) for the infusion system. Diode CR10, resistor R23, IC U4, and capacitor C19 constitute a secondary +12 VDC control loop for protection in case of primary loop failure. Diode CR12 and capacitor C25 create a feed-forward converted negative voltage across capacitor C25 to switch transistor Q9 on through resistor R57 and diode CR14. The Q9 output, housekeeping DC (HKDC), provides the necessary voltage to power both the main regulation loop and the charger circuitry. HKDC is at ground potential when AC (mains) is off and CR12 blocks unnecessary battery power drain. Resistors R58, R59, and R60; capacitors C30, C31, and C32; and IC U9 filter HKDC and create a stable +2.5 VDC reference voltage (F2.5V).

Resistors R21, R39, R44, and R45; capacitor C27; and components U8B and U3 constitute the main control loop. Transistor Q7, resistor R42, and diode CR9 eliminate latch-up at AC (mains) power-up by enabling voltage regulation only after +BUSS reaches +9 VDC.

4.2.1.2

VOLTAGE REGULATOR CIRCUITRY



The primary function of the voltage regulator circuitry is to provide constant DC level output. The motor voltage (VMOT) regulator circuitry (U8A, Q5, Q4, and associated passive components) provides a constant +9.35 VDC output when AC (mains) is on. Transistor Q2 remains forward-biased by HKDC through diode CR8 and resistors R11 and R12. While Q2 remains on, transistor Q3 is disabled to inhibit POWERHOLD and SPSTIN (single-pole, single-throw in) effect on the VMOT voltage regulator.

When AC (mains) is off, Q2 is disabled. If battery operation is required, Q4 is turned on momentarily by the SPSTIN signal and permanently by POWERHOLD. Since Q2 is off, Q4 switches the battery voltage through the VMOT circuitry to supply voltage to the necessary circuits, including the +5 VDC regulator U5. IC U5, the +5 VDC low-drop voltage regulator, powers most of the digital circuits in the infusion system.

4.2.1.3

BATTERY CHARGER CIRCUITRY

The primary function of the battery charger circuitry is to charge the battery. The main component of the battery charger circuitry is a constant current source comprised of transistors Q6 and Q8, IC U6B, resistor R33, and associated passive devices. Q6 is the current carrying device and R33 is the sense resistor.

When AC (mains) is off, Q8 is off and Q6 is on.

The battery is charged by two current levels and trickle current (R20). Charge current control is achieved by controlling the voltage at U6-6 by the signals LOCHG (low charge), CHRГ_OFF (charge off), and BAT2 (battery 2). The BAT2 signal is active when a short is introduced at battery connector J26-3 and -4 (an active BAT2 signal implies battery type 2 is connected to connector J26). In this case, the charge current is lower since Q10 is on.

Table 4-1, Battery Charge Current States, lists the charge current state as a function of the control signals.

Note: *Table 4-1* applies to all 115 VAC and 220 VAC infusion systems.

| LOCHG Signal | CHRГ_OFF Signal | J26-3 to J26-4 | Approximate Current |
|---------------------|------------------------|-----------------------|----------------------------|
| Low | Low | Short | 0.8 A |
| Low | Low | Open | 1.2 A |
| High | Low | Short | 0.16 A |
| High | Low | Open | 0.25 A |
| Don't care | High | Don't care | Trickle = (11-Vbat)/475 |

IC U7A also offers overpower protection for transistor Q6. When the voltage across Q6 generates more than +2.5 VDC at U7-4, the charge current switches to low.

The LOCHG_REQ (low charge request) signal alerts the MCU PWA of the battery voltage level. LOCHG_REQ is generated by ICs U6A, U7B, U7C, U7D, and associated passive components.

IC U6A, resistors R24 through R28, and capacitor C20 constitute a differential amplifier that monitors the battery voltage as the battery is being charged. The output of the differential amplifier is compared to a previously determined level by voltage comparator U7C. U7C generates the LOCHG_REQ signal. The voltage level depends on whether U7-13 or -1 is low or, alternately, whether battery one or battery two is connected.

4.2.2

POWER SUPPLY PWA



The power supply PWA consists of switcher circuitry, voltage regulator circuitry, and battery charger circuitry. Refer to [Figure 9-24, Power Supply PWA Schematic \(XL International\)](#), or [Figure 9-26, Power Supply PWA Schematic \(XLM International\)](#). The power supply PWA includes the following operational modes:

- AC (mains) off. Infusion system is not connected to mains voltage and is not operating
- AC (mains) off, infusion system on. Infusion system is not connected to mains voltage and is operating
- AC (mains) on. Infusion system is connected to mains voltage and is not operating
- AC (mains) on, infusion system on. Infusion system is connected to mains voltage and is operating

4.2.2.1

SWITCHER CIRCUITRY



The switcher circuitry converts AC (mains) voltage to an isolated +11 VDC power through flyback topology.

Fuses F1 and F2, and variable resistors VR1 and VR2 provide protection against high-line voltage spikes and abnormally high input power demands. Capacitors C1, C2, C35, C36, C37, and C38, transformer T1, and inductor L1 are designed for attenuating the conducted emissions. IC U1, resistor R1, inductor L1, and capacitor C3 provide the DC voltage required for conversion by the switcher. Diodes CR1, CR2, CR4, and CR15; resistors R22, R68, R73, and R74; capacitors C4, C9, and C34; and transistors Q11 and Q12 provide the DC voltage for IC U2, the current mode switcher controller IC.

A UL-544 isolation barrier surrounds transistor Q1, transformer T2, IC U2, and associated passive components to minimize radiated EMI. Optocoupler U3 is part of the main regulation loop that provides the UL-544 isolation barrier.

IC U2 oscillates at approximately 40 kHz, a frequency dictated by the values of resistor R4 and capacitor C5. U2 controls the duty cycle of transistor switch Q1 through resistors R5 and R6, and diode CR16. Resistor R9 provides the current sense and resistor R8 and capacitor C7 filter the ramp voltage across R9 and feed it back to IC U2.

U2 configuration allows DC voltage at pin 9 (ERR+) to equal the peak voltage across resistor R9. This DC voltage controls the delivered power through transformer T2 to regulate the output voltage. Voltage at U2 pin 9 is limited to +1.25 VDC so that peak current through transistor Q1 is limited to 1.25 VDC divided by the value of resistor R9.

Resistors R61 and R72, diode CR5, and capacitor C6 provide transformer T2 winding short protection by applying the higher voltage across resistor R9 to the U2 inhibit input. C6 and the input impedance at U2-4 apply the low hiccup frequency to protect transistor Q1.

Diode CR3 and the clamp winding of transformer T2 provide intermediate energy transfer to capacitor C3 and limit the peak voltage across transistor Q1.

At AC (mains) power-up, capacitor C12 provides delayed timing to permit the voltage potential at U2-14 (Vcc) to reach its minimum level. Diode CR11, and capacitors C18, C23, and C24 rectify the transformer T2 voltage to create the main DC voltage source for the infusion system. Diode CR10, resistor R23, IC U4, and capacitor C19 constitute a secondary +12 VDC control loop for protection in case of primary loop failure. Diode CR12 and capacitor C25 create a feed-forward converted negative voltage across capacitor C25 to switch transistor Q9 on through resistor R57 and diode CR14. The Q9 output, housekeeping DC (HKDC), provides the necessary voltage to power both the main regulation loop and the charger circuitry. HKDC is at ground level when AC (mains) is off and diode CR14 inhibits unnecessary battery power drain. Resistors R58 through R60, capacitors C30 through C32, and IC U9 filter HKDC and create a stable +2.5 VDC reference voltage (F2.5V). Both HKDC and F2.5V are at ground level when AC (mains) is off.

IC U8B, with resistors R7, R21, R39, R43 through R45, capacitor C27, and IC U3 constitute the main loop control. Transistor Q7, resistor R42, and diode CR9 eliminate latch-up at AC (mains) power-up by enabling voltage regulation only after +BUSS reaches +9 VDC.

4.2.2.2

VOLTAGE REGULATOR CIRCUITRY



VMOT voltage regulator circuitry (U8A, Q5, and Q4 and associated passive components) is at 9.35 VDC when AC (mains) is on.

Transistor Q2 remains forward-biased by HKDC through diode CR9 and resistors R11 and R12. While transistor Q2 remains on, transistor Q3 is disabled to inhibit POWERHOLD and SPSTIN from affecting the voltage regulator circuitry.

When AC (mains) is off, transistor Q2 is disabled. If battery operation is required, transistor Q4 is turned on momentarily by the SPSTIN signal and permanently by POWERHOLD through transistor Q3. Since Q2 is off, transistor Q4 switches the battery voltage through the VMOT circuitry to supply voltage to the necessary circuits, including the +5 VDC regulator U5. IC U5, the +5 VDC low-drop voltage regulator, powers most of the digital circuits in the infusion system.

4.2.2.3

BATTERY CHARGER CIRCUITRY



The primary part of the battery charger is the constant current source, comprised of transistors Q6 and Q8, IC U6B, resistor R33, and associated passive devices. Transistor Q6 is the current-carrying device, and resistor R33 is the sense resistor. When AC (mains) is off, transistor Q8 is off and transistor Q6 is on.

The battery is charged by two current levels and trickle current (resistor R20). Current level is achieved by controlling the voltage at U6-6. IC U7A, transistor Q10, and resistors R31, R32, R34, R62, and R63 control the voltage at U6-6, and hence, the current level. The BAT2 signal is high (not logic level) when a short is introduced at the battery connector J26 pins 3 and 4, which implies that battery type 2 is connected to connector J26. In this case, the battery charge current is low since transistor Q10 is on.

IC U7A also serves as an overpower protection for transistor Q6. When the voltage across Q6 generates more than 2.5V at U7-4, the charge current switches to low.

The LOCHG_REQ signal alerts the MCU PWA of the battery voltage level; it is generated by U6A, U7B, U7C, U7D and associated passive components.

IC U6A, resistors R24 through R28, and capacitor C20 constitute a differential amplifier that reads the battery voltage as it is being charged. The output of the differential amplifier is compared to a previously determined level by U7C. U7C generates the LOCHG_REQ. The voltage level depends on whether U7-13 or U7-1 is low or, alternatively, whether battery type 1 or battery type 2 is connected.

4.2.3

MCU PWA

The MCU PWA contains micro controller U6 (*see Figure 9-15, MCU PWA Schematic (XL), Figure 9-16, MCU PWA Schematic (XLM), or Figure 9-17, MCU PWA Schematic (XLM with DataPort)*). The MCU PWA has five digital ports and one analog port. Each port is eight lines wide. The MCU PWA also includes the following circuitry:

- Watchdog
- Serial communication
- Alarm
- Alarm power backup
- Motor drivers
- Pin detector
- Universal asynchronous receiver/transmitter (UART) (XLM with DataPort)

4.2.3.1

WATCHDOG CIRCUITRY

The watchdog circuitry continuously monitors the MCU PWA and contains IC U14. U14 is strobed by micro controller U16 at a predetermined minimum frequency; otherwise, the *RESET output becomes active. *RESET also becomes active if digital voltage (VDIG) is out of range. *RESET causes the MCU PWA to reset, blocks any signal to the motors, and turns the alarm on.

4.2.3.2

SERIAL COMMUNICATION CIRCUITRY

The serial communication circuitry interchanges data between the MCU PWA and either the liquid crystal display (LCD) screen or the electrically erasable programmable read-only memory (EEPROM).

Although data is transmitted to both the LCD screen and the EEPROM, the clock is diverted only to the selected receiver. If EE_CS is active, then *SCK appears as EE_CLK at IC U9C. If EE_CS is inactive, then *SCK is inverted to appear as LCD_CLK at IC U8B.

Data is read from either the LCD screen or the EEPROM. If EE_CS is active, then EE_DO appears as RXD at IC U7C. If EE_CS is inactive, then LCD_DO is inverted to appear as RXD at IC U7C.

4.2.3.3

ALARM CIRCUITRY (XL)

The alarm circuitry includes an oscillator circuit consisting of inverters U10C, U10B, and U10E. The oscillator circuit generates acoustic power at a predetermined frequency based on the BUZ1 self resonance. Normally, the BUZZER signal is low, U9-10 is high, and resistor network RN8-7 and RN8-8 disables the oscillator. The alarm can be activated by the BUZZER or *RESET signals becoming active and pulling RN8-7 down. When SW1 is set to LO, resistor R13 is electronically connected to the BUZ1-3 (buzzer drive) and the sound level decreases. U10D and U10F constitute a memory unit that disables the oscillator circuit when the U10F output is high.

At AC (mains) power-up, POWERHOLD becomes active and changes the U10D/U10F memory unit to enable the oscillator circuit. At a voluntary power-off, DIST_AIR_EN and PROX_AIR_EN become momentarily active. This momentary activation of DIST_AIR_EN and PROX_AIR_EN allows the memory unit to change to an oscillator-disabling state and the alarm does not sound. At a catastrophic failure, however, the memory unit remains enabled and the alarm sounds.

During a catastrophic failure, the alarm can be disabled by positioning the infusion system control knob to OFF/CHARGE.

4.2.3.4

ALARM CIRCUITRY (XLM)

The alarm circuitry includes an oscillator circuit consisting of inverters U10C, U10B, and U10E. The oscillator circuit generates acoustic power at a predetermined frequency based on the BUZ1 self resonance. Normally, the BUZZER signal is low, U9-10 is high, and resistor network RN8-7 and RN8-8 disables the oscillator. The alarm can be activated by the BUZZER or *RESET signals becoming active and pulling RN8-7 down. U10D and U10F constitute a memory unit that disables the oscillator circuit when the U10F output is high.

At AC (mains) power-up, POWERHOLD becomes active and changes the U10D/U10F memory unit to enable the oscillator circuit. At a voluntary power-off, DIST_AIR_EN and PROX_AIR_EN become momentarily active. This momentary activation of DIST_AIR_EN and PROX_AIR_EN allows the memory unit to change to an oscillator-disabling state and the alarm does not sound. At a catastrophic failure, however, the memory unit remains enabled and the alarm sounds.

During a catastrophic failure, the alarm can be disabled by positioning the infusion system control knob to OFF/CHARGE.

The alarm circuitry provides sound for low-level settings only. For high-level sound, [see Section 4.2.4, Buzzer PWA \(XLM\)](#).

4.2.3.5

ALARM POWER BACKUP CIRCUITRY

The alarm power backup circuitry is provided through super capacitor C34. C34 offers power backup in the event of a catastrophic failure. Diodes CR15, CR19, and CR20 route the power for alarm driver U10 from VDIG or C34.

4.2.3.6**MOTOR DRIVER CIRCUITRY**

The motor driver circuitry energizes the three stepper motors: plunger, input/output, and primary/secondary. The MCU PWA micro controller, U6, outputs MOTPHAS1 and MOTPHAS2 to inverters U9A and U9F which generate two additional signals: *MOTPHAS1 and *MOTPHAS2. These four signals are required to step the motors. Three motor enable signals manage the motor step width. The motor enable signals are: MOTPLN_EN (motor plunger enable), MOTIO_EN (motor input/output enable), and MOTPS_EN (motor primary/secondary enable). The four motor stepping signals activate ICs U2A, U3A, U3D, and U2D; or U2B, U3B, U3C, and U2C; or U5D, U5A, U4A, and U4D to switch the power metal-oxide semiconductor field-effect transistors (MOSFETs) Q1 through Q4, Q5 through Q8, or Q9 through Q12. When active, *RESET disables motor activity.

4.2.3.7**PIN DETECTOR CIRCUITRY**

The pin detector circuitry detects the primary and secondary valve pin motion. When PSV_EN is active, *PSV_EN becomes active and a constant current flows through light-emitting diode (LED) CR1 and LED CR2. CR1 and CR2 are located in the pin detector sensor assembly mounted on the bubble sensor PWA. If *P_S_EN is active, IC U11A is activated and U11B is de-activated, and vice versa. U11 serves as two hysteresis comparators and its output, PS_VALVE, is edge detected by the MCU PWA. The positive edges are detected by the MCU PWA INT1 input. The negative edges are detected by the MCU PWA PC3 input.

4.2.3.8**UART (XLM WITH DATAPORT)**

The UART used in the Plum XLM with DataPort infusion system is TL16C450 made by Texas Instruments. It is a complementary metal-oxide semiconductor (CMOS) field-effect transistor (FET) version of an asynchronous communication element (ACE) typically functioning in a microcomputer system as a serial input/output interface.

The UART performs serial-to-parallel conversion on data received from the host computer and performs parallel-to-serial conversion on data received from the MCU. The MCU can read the status of the UART at any point in its operation. The status information includes the type of transfer operation in progress, the status of the operation, and any error conditions encountered.

The UART includes a programmable, on-board baud rate generator which is capable of dividing a reference clock input by divisors from 1 to (216 - 1) and producing a 16 x clock to drive the internal transmitter logic. Provisions are also included to use this 16 x clock to drive the receiver logic. In the Plum XLM with DataPort infusion system, data is transmitted and received at 1,200 bits per second. The 16 x clock is running at 19,200 Hz (16 x 1,200).

The UART includes a complete modem control capacity and a processor interrupt system that is software adjustable to user requirements to minimize the computing required to handle the communication link. The software of the Plum XLM with DataPort infusion system programs the UART not to use its modem control capacity, but to interrupt the MCU when a byte of data is received from or transmitted to the host computer.

 **Note:** Do not connect DataPort when infusing.

4.2.3.9

NURSE CALL ALARM (XLM WITH DATAPORT - NURSE CALL)

During an alarm, an isolated contact closure is made by U22, a solid-state FET relay. The BUZZER signal from the microprocessor is filtered to maintain the contact closure between short beeps by the diode and RC network at the input to the driver U5.

The connection to the nurse call feature is made by an adapter that mates to the 15-pin serial port. The nurse call adapter connects to existing signalling equipment with a 1/4 inch phone plug.

 **Note:** Nurse call alarm is not available in IEC compliant infuser. 

 **Note:** Do not connect DataPort when infusing.

4.2.4

BUZZER PWA (XLM)

The buzzer PWA is installed on the Plum XLM and XLM with DataPort (*see Figure 9-28, Buzzer PWA Schematic*). The buzzer PWA includes the following circuitry:

- High volume audible alarm
- Lockout switch

4.2.4.1

HIGH VOLUME AUDIBLE ALARM

In addition to the MCU PWA alarm circuitry, a loud piezo alarm buzzer is installed on the buzzer PWA for high volume setting (*see Section 4.2.3.4, Alarm Circuitry (XLM)*). The high volume setting is selected by lever switch SW1. Switch SW1 is located on the buzzer PWA, and during normal operation is accessible on the rear enclosure.

The BUZZER_HI signal connects to the central processing unit (CPU) port on the MCU PWA. The SPSTIN_BUZ signal connects to the SPSTIN (+BUSS) signal on the MCU PWA. SPSTIN_BUZ is the battery charging voltage. When an alarm occurs, the processor activates BUZZER_HI. When the switch SW1 is closed (high setting), the high volume piezo buzzer and the alarm circuitry on the MCU PWA activate. When switch SW1 is open (low setting), only the MCU PWA alarm circuitry activates.

4.2.4.2**LOCKOUT SWITCH**

The lockout switch SW2 is located on the buzzer PWA and is accessible on the rear enclosure of the Plum XLM. The lockout switch is connected to the LOCKOUT1 signal on the display PWA, and to the LOCKOUT2 signal on the MCU PWA. LOCKOUT1 connects to the collector of Q7 on the display PWA. When lockout switch SW2 is closed, and Q7 saturates, LOCKOUT2 goes low and the LOCKED icon on the LCD illuminates.

4.2.5**DISPLAY PWA**

The display PWA receives serial data from the MCU PWA and displays it at the LCD (*see Figure 9-18, Display PWA Schematic (XL), or Figure 9-19, Display PWA Schematic (XLM)*). The display PWA also includes most of the control knob functions required to operate the infusion system. The display PWA includes the following circuitry: display, electroluminescent (EL) panel driver (XL), LED backlight panel and driver (XLM), RUN indicator, line power indicator, and control knob.

4.2.5.1**DISPLAY CIRCUITRY (XL)**

ICs U2 and U3 are master- and slave-type serial input LCD drivers and are cascaded to form a 92-segment (4 back-plane by 23 fore-plane) driver. LCD panel U1 is designed to match the drivers and has 88 segments.

Display data is serially clocked into U2 at pin 21. The clocking signal, LCD CLK, is received at U2-23 and U3-22. The drive frequency is not synchronized to the data input and is dictated by resistor R7. To eliminate a false display during data updates, U2 and U3 are disabled by CR3, C14, R9, R8, and Q3.

4.2.5.2**DISPLAY CIRCUITRY (XLM DISPLAY PWA -003 AND LOWER)**

IC U2 is the 128 segment LCD driver that can drive the four backplanes and 32 frontplanes. LCD panel U4 has 110 front panel segments multiplexed with the four backplanes.

Display data is clocked serially into U2 via DIN (pin 39) and DCLK (pin 38). The LCD drive frequency (approximately 100 Hz) is set by R7 and is not synchronized to the data input into U2.

4.2.5.3**DISPLAY CIRCUITRY (XLM DISPLAY PWA -004 AND HIGHER)**

IC U13 is the 128 segment LCD driver that can drive the four backplanes and 32 frontplanes. LCD panel U4 has 110 front panel segments multiplexed with the four backplanes.

Display data is clocked serially into U13 via DATA (pin 58) and SCL (pin 57). The LCD drive frequency (approximately 100 Hz) is set by R31 and is not synchronized to the data input into U13.

4.2.5.4**EL PANEL DRIVER CIRCUITRY (XL)**

Transistor Q1 and transformer T1 windings 1-3 (primary) and 4-2 (feedback) constitute the main oscillator positive feedback. The T1 output winding (5, 8) provides a large-turn ratio (to T1 primary winding) to boost the output to 300 volts peak-to-peak (Vpp). The capacitance of EL panel EL1 and the inductance of the T1 output winding dictates the oscillation frequency of 300 Hz to 500 Hz. As the capacitance of EL1 decreases because of aging, the frequency increases to maintain a constant brightness.

A control loop consisting of diode CR1; capacitors C13 and C10; resistors R13, R4, R3, and R6; IC U10B; and transistor Q2 maintains a constant output amplitude by rectifying the output and comparing it to the ELON signal.

4.2.5.5**LED BACKLIGHT PANEL AND DRIVER (XLM)**

The display backlight panel is an array of 60 LEDs arranged as parallel elements of two series LEDs. The required drive voltage of the panel equals two LED voltage drops of approximately 4.2 VDC. The actual forward voltage changes with temperature and varies from panel to panel. Driving the panel with a constant current compensates for varying voltage requirements.

The XLM backlight panel requires approximately 200 mA for optimum brightness. The current is controlled utilizing a current mode switching technique enabling high efficiency operation with a wide power supply range of 7 to 11 volts. The signal VMOT is the supply voltage for the backlight constant current regulator.

Current through U5, LED panel, is regulated by Q3 operation until the voltage across current sensing resistors R14, R23, and R24 exceeds a reference voltage of approximately 96 mV. The voltage drop is filtered by R13 and C7 and then compared to the turn-off threshold determined by the voltage divider R11 and R12. Comparator U3, pin 1 drives low when the current through R14, R23, and R24 exceeds the turn-off threshold, discharging C4. U1 senses the quick discharge of C1 and then turns off Q1.

Q1 remains off while C4 charges via resistor R9. Q3 turns on when the the charge on C4 exceeds the input voltage high threshold of U3, pin 2.

4.2.5.6**RUN INDICATOR CIRCUITRY**

LEDRUN, when active, turns LED1 on. IC U10A (Q8 XLM) functions as a constant current source to LED1 by maintaining constant voltage across resistor R20. The voltage is approximately +3.33 VDC.

4.2.5.7**LINE POWER INDICATOR CIRCUITRY**

HKDC is active when the infusion system is operating on AC (mains), and turns on the line power indicator, LED2. HKDC brings transistor Q4 base voltage to VDIG + Vf through R15 (Vf equals forward voltage of diode CR1). This base voltage change causes Q4 to conduct and the current through LED2 equals approximately VDIG divided by the value of resistor R14.

4.2.5.8**CONTROL KNOB CIRCUITRY (XL)**

The control knob circuitry consists of transistor Q5; rotary switch Hall-effect sensors U11 through U15; reed switch S7; ICs U4, U5, and U7 through U9; and associated passive components. The control knob circuitry senses the control knob position and sends the position code to the MCU PWA. The HSENSEN signal, when active, switches transistor Q5 on and allows the output of rotary switch Hall-effect sensors U11 through U15 to be gated through ICs U4, U5, and U7 through U9. Resultant output conditions of rotary 0 (ROT0), ROT1, and ROT2 at ICs U9B, U7B, and U7A are sent to the MCU PWA as a three-bit code representing the control knob position. The S7 reed switch output, SPSTIN is transferred to the power supply PWA. If more or less than one Hall-effect sensor position signal is active, ROT0, ROT1, and ROT2 become active simultaneously to signify a failure. If the control knob is set to the OFF/CHARGE position, *SESTIN is enabled.

4.2.5.9**CONTROL KNOB CIRCUITRY (XLM)**

The control knob circuitry consists of transistor Q5; rotary switch Hall-effect sensors U11 through U15; reed switch S7; ICs U4, U5, U7, and U8; and associated passive components. The control knob circuitry senses the control knob position and sends the position code to the MCU PWA. The HSENSEN signal, when active, switches transistor Q5 on and allows the output of rotary switch Hall-effect sensors U11 through U15 to be gated through ICs U4, U5, U7, and U8. Resultant output conditions of rotary 0 (ROT0), ROT1, and ROT2 at ICs U7A, U7B, and U7D are sent to the MCU PWA as a three-bit code representing the control knob position. The S7 reed switch output, SPSTIN is transferred to the power supply PWA. If more or less than one Hall-effect sensor position signal is active, ROT0, ROT1, and ROT2 become active simultaneously to signify a failure. If the control knob is set to the OFF/CHARGE position, *SESTIN is enabled.

4.2.6**SENSOR PWA**

The sensor PWA consists of the following circuitry: pressure amplifier/filter, AC (mains) amplifier, voltage reference, opto interrupter, and EEPROM (*see Figure 9-21, Sensor PWA Schematic*).

4.2.6.1**PRESSURE AMPLIFIER/FILTER CIRCUITRY**

The pressure amplifier circuitry (IC U7, resistors R6 and R11 through R16, and capacitors C2 and C3) is a differential amplifier with an approximate gain of 600. Capacitors C2 and C3 are part of an automatic-zero system within U7. The combination of resistors R13 and R11 makes it possible for R12 (trimpot) to compensate for up to a 3 millivolt (mV) offset input from the strain gauge. In case of larger offsets, R13 must be removed from the sensor PWA. R12 is adjusted to approximately +0.7 VDC at distal pressure (DISTPRES) so that negative pressure spikes can be read by the MCU PWA.

The filter circuitry (resistors R1 and R3, capacitors C4 and C5, and IC U8A) constitutes a two-pole, 30 Hz Bessel active filter. The filter alternates the 500 Hz automatic-zero switching frequency of U7 and other noise.

4.2.6.2

AC AMPLIFIER CIRCUITRY

The AC (mains) amplifier circuitry (IC U8A) processes negative spikes that may signify an occlusion on DISTPRES to a level manageable by the MCU PWA analog-to-digital (A/D) converter. The AC amplifier blocks slow pressure changes and amplifies the spikes to the required level. The AC amplifier also divides into the logarithmic compression circuit (resistor R7 and diodes CR1 and CR3), the bias/high-pass circuit (capacitor C8 and resistor R10), and the amplifier circuit (IC U8B, resistors R4 and R9, and capacitor C7). The logarithmic compression circuit limits the amplitude of the negative spikes at high back-pressure. The bias/high pass circuit blocks the slow pressure changes and biases the AC (mains) amplifier to +2.5 VDC.

4.2.6.3

VOLTAGE REFERENCE CIRCUITRY

The voltage reference circuitry consists of ICs U1 and U6; transistor Q1; diodes CR2 and CR5; resistors R17 through R20, R22, and R23; and capacitors C9, C11, and C12. R22, C11, and C12 filter VMOT. R18 biases the reference U1. U6B buffers the +2.5 VDC REF. The +2.5 VDC REF is boosted by Q1, U6A, and associated components to generate the main +3.75 VDC reference 3V75REF. CR2 limits 3V75REF to VDIG level to protect the MCU PWA micro controller, U6. CR5 protects the base-emitter junction of Q1.

4.2.6.4

OPTO INTERRUPTER CIRCUITRY

When PSENSEN is active, transistors Q2 and Q3 drive all LEDs in ICs U2, U3, and U4 with a constant current of approximately 22 milliamperes (mA). Resistor R24 limits the current.

4.2.6.5

EEPROM CIRCUITRY

The EEPROM circuitry (IC U5) communicates serially with the MCU PWA. U5 receives commands and data through pin 3 as TXD. Stored data is transferred through pin 4 as EE_DO. When EE_CS is active at pin 1 and EE_CLK (pin 2) is in synchronization with TXD, U5 is enabled.

4.2.7

BUBBLE SENSOR PWA

The bubble sensor PWA consists of the following circuitry: transmitter, receiver (which includes two channels, proximal and distal), and pin detector flex (*see Figure 9-21, Sensor PWA Schematic*, and *Figure 9-22, Pin Detector Flex Circuit Schematic*).

 **Note:** Both proximal and distal sensors can transmit or receive.

4.2.7.1**TRANSMITTER CIRCUITRY**

The transmitter circuitry consists of a sweep oscillator, a voltage-controlled oscillator (VCO), and a driver.

The sweep oscillator (ICs U1A and portion of U2, capacitor C5, and resistor R15 through R18) oscillates at approximately 12 kHz with a 50 percent duty cycle. A CMOS gate within U2 is used for a quality rail-to-rail symmetrical signal for greater timing accuracy. The output of the sweep oscillator (C2) is between +2 VDC and +3 VDC. The C2 output is used to sweep the VCO at U2-9.

IC U2, capacitor C7, and resistor R21 constitute the VCO. U2 is originally a phase-lock loop (PLL) IC with the VCO portion sweeping output frequencies from 4 MHz to 6 MHz. The VCO center frequency is determined by R21 and C7. Activating either signal, PROX_AIR_EN or DIST_AIR_EN, enables the VCO.

The driver consists of a push-pull, emitter-follower complementary pair of transistors: Q4 and Q5. The driver supplies input to proximal sensor X1 and distal sensor X2.

4.2.7.2**RECEIVER CIRCUITRY**

The receiver consists of an amplifier, detector, and buffer.

The amplifier consists of transistors Q3, Q6, Q2, and associated passive components. The amplifier is biased by 2V5REF and is designed for wide power supply range. Q3 is biased by PROX_AIR_EN in order to receive from proximal sensor X1. Q6 is biased by DIST_AIR_EN to receive from distal sensor X2.

The detector is an emitter-follower transistor Q1. Q1 allows maximum input impedance. Capacitor C1 and resistor R4 constitute a time constant of 200 microseconds (μ S). Since the time between peaks is approximately 40 μ S, the output (*AIR_OPT) remains high with a pronounced sawtooth ripple.

The buffer (IC U1A and resistors R7 and R2) also amplifies the detected signal.

4.2.7.3**PIN DETECTOR FLEX CIRCUITRY**

The pin detector flex circuitry detects movement of the primary and secondary valve pins by optical transmitters CR1 and CR2, and optical receivers Q1 and Q2. Light interrupters are attached to the pins and as the pins move, the appropriate valve movement signals are transferred to the MCU PWA through the bubble sensor PWA.

4.3

MECHANICAL OVERVIEW

The principal mechanical elements of the infusion system include the cassette and the mechanism assembly. When a cassette is locked into the operating position and the control knob is turned on, the infusion system performs a self test to verify the integrity of the internal systems. The operation of the mechanism assembly moves a plunger, causing a pumping action. A valve motor selects the primary or secondary valve, depending on the command. An additional valve motor alternately opens and closes an inlet valve and outlet valve to control fluid flow through the cassette pumping chamber.

The following sections detail the cassette and the mechanism assembly.

4.3.1

CASSETTE

The cassette operates on a fluid displacement principle to volumetrically deliver fluid (*see Figure 4-1, Major Elements of the Dual-Channel Cassette*, and *Figure 4-2, Fluid Path in the Cassette*). Refer to the system operating manual for a description of the major cassette functions.

The pumping cycle begins when the outlet valve is opened and the inlet valve is closed. The plunger extends to deflect the cassette diaphragm and expel fluid. At the end of the pumping stroke, the outlet valve closes, the inlet opens, the appropriate primary or secondary valve opens, and the plunger retracts to allow fluid to refill the pumping chamber. After the pumping chamber is filled, the inlet and outlet valves are reversed, the primary and secondary valves are closed, and the cycle is repeated.

The cassette contains two chambers: an upper air trap chamber and a pumping chamber. The two chambers are separated by an inlet valve (*see Figure 4-1* and *Figure 4-2*) and operate together to detect air. The upper air-trap chamber receives fluid from the intravenous (IV) container through either the primary or secondary valve. The upper air-trap chamber collects air bubbles from the IV line and container to prevent them from entering the pumping chamber; the chamber can collect a substantial amount of air. The controller tracks the amount of air collected in the upper air-trap chamber. If a predetermined air collection threshold is exceeded, the controller starts an infusion system backprime and initiates a secondary display.

A proximal air-in-line sensor (bubble detector) is located between the primary/secondary valves and the upper air-trap chamber. The proximal air-in-line sensor detects air entering the upper air-trap chamber and initiates an audible alarm if the predetermined air collection threshold is exceeded. Similarly, a second air-in-line sensor located distal to the pumping chamber initiates an audible alarm if a predetermined amount of air is detected.

The pumping chamber receives fluid from the upper air-trap chamber through an inlet valve. When the diaphragm covering the pumping chamber is deflected by the plunger, the pumping chamber expels fluid through an outlet valve. A pressure sensor located distal to the pumping chamber monitors pressure on the distal side of the cassette.

A flow regulator is incorporated into the cassette distal end. This flow regulator is used to manually control flow when the cassette is not inserted in the pump. When the cassette is properly inserted into the infusion system and the infusion system door is closed, a mechanism opens the flow regulator to allow the infusion system to control fluid flow. When the infusion system door is opened, the same mechanism closes the flow regulator to disable fluid flow.

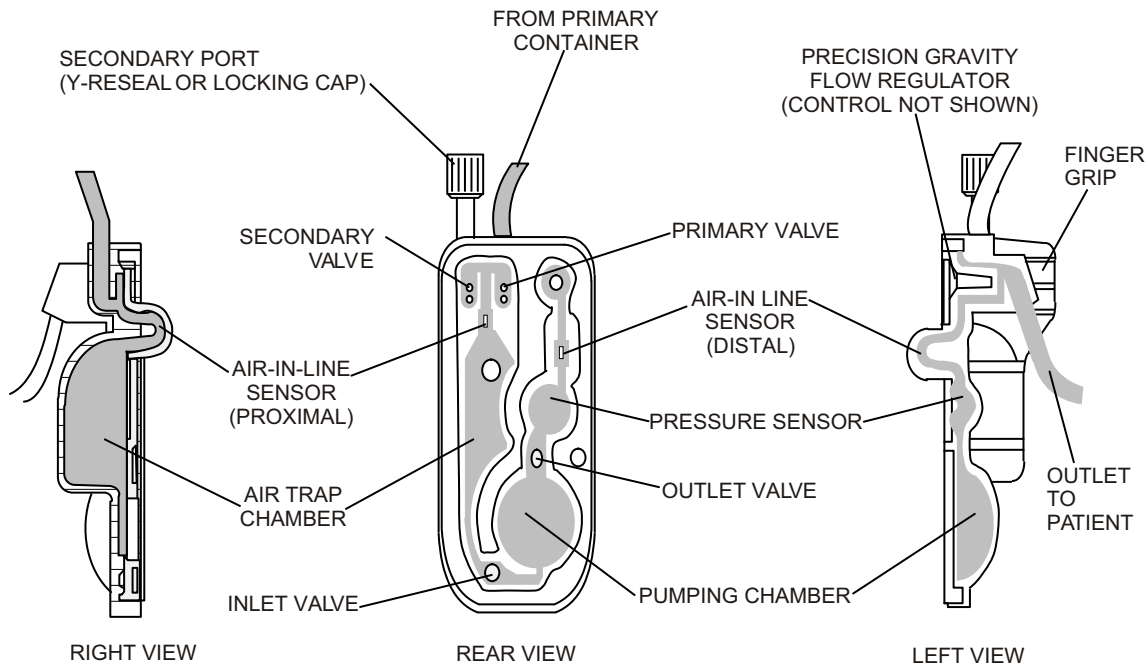

01K04004

Figure 4-1. Major Elements of the Dual-Channel Cassette

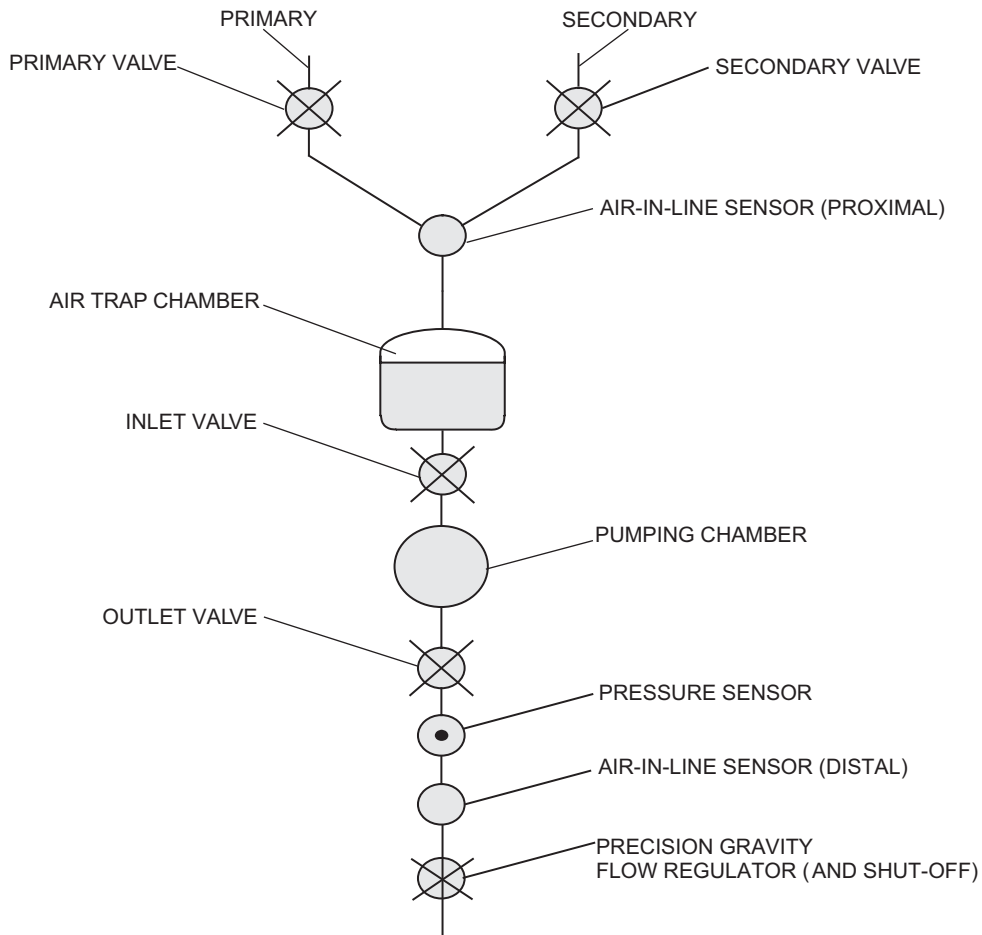

04K01002

Figure 4-2. Fluid Path in the Cassette

4.3.2

MECHANISM ASSEMBLY

The mechanism assembly is a fully self-contained unit consisting of the motor and valve assemblies, primary/secondary valve subsystem, inlet/outlet valve subsystem, plunger drive subsystem, air bubble (ultrasonic) sensor assemblies, cassette door, and pressure sensor assembly. The motor and valve assemblies, primary/secondary valve subsystem, inlet/outlet valve subsystem, and plunger drive subsystem are detailed in the following sections.

During infusion system operation, the mechanism assembly plunger motor drives a lead screw that is coupled to a nut in the plunger. The motor action and lead screw move the plunger forward to cause the delivery of approximately 0.33 mL of fluid per cycle. The plunger motion is synchronized to the valve motors to provide controlled fluid delivery.

4.3.2.1

MOTOR AND VALVE ASSEMBLIES

The mechanism assembly pumping action is controlled by three stepper motors. The first stepper motor, in conjunction with an associated valve assembly, activates the primary or secondary valve of the cassette, depending on the command. The second stepper motor alternately opens and closes the inlet and outlet valve to control fluid delivery through the cassette pumping chamber. A third stepper motor controls plunger movement.

4.3.2.2

PRIMARY/SECONDARY VALVE SUBSYSTEM

The primary/secondary valve subsystem includes a motor designed to rotate a cam (*see Figure 4-3, Mechanism Valve Pins and Sensor Locations*). When the cam is positioned at the top dead center (home position), both valves are closed. Clockwise rotation (when viewed from the motor side) from the home position opens the primary valve, while the secondary valve remains closed. Counterclockwise rotation opens the secondary valve, while the primary valve remains closed.

The primary/secondary valve subsystem consists of a stepper motor with attached cam and integral cam flag, primary and secondary rockers and valve pins, and a pin detector assembly. The cam flag passes through an interrupter module as it rotates with the cam. Valve home position is determined by this cam flag/interrupter module combination through predetermined factory calibration data. During operation, if the cam flag passes through the interrupter module at the incorrect time sequence, a motor phase loss is detected.

The rocker is the connecting link between the cam and the valve pin.

The primary/secondary valve pins each have a series of interrupters that are optically detected by the pin detector assembly to assure proper valve pin movement.

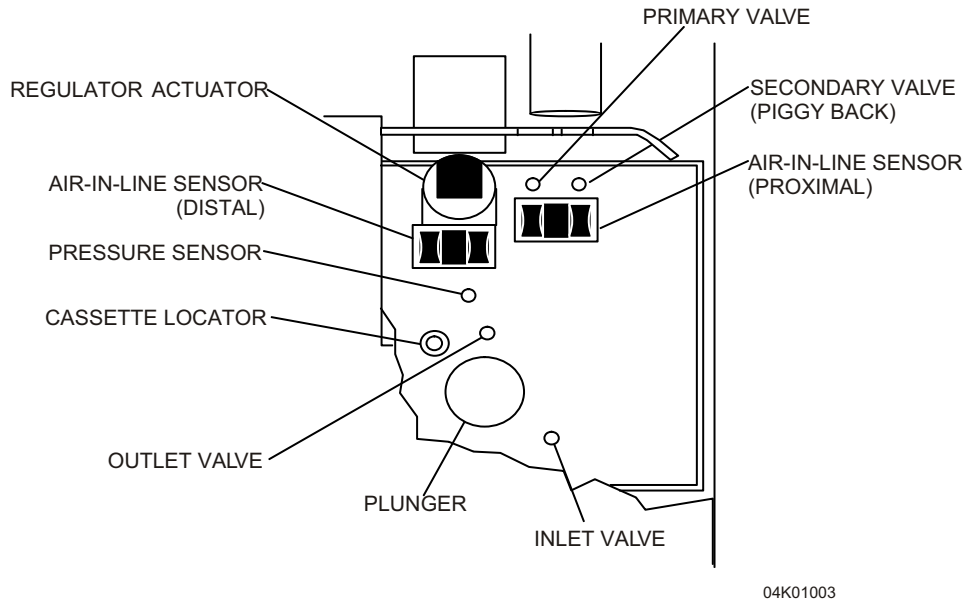

Figure 4-3. Mechanism Valve Pins and Sensor Locations

4.3.2.3

INLET/OUTLET VALVE SUBSYSTEM

The inlet/outlet valve subsystem is similar in function and build to the primary/secondary valve subsystem, but it does not contain a series of interrupters or a pin detection assembly. Refer to [Section 4.3.2.2, Primary/Secondary Valve Subsystem](#), for the inlet/outlet valve subsystem theory of operation.

4.3.2.4

PLUNGER DRIVE SUBSYSTEM

The plunger drive subsystem includes a stepper motor. The stepper motor rotates approximately 1-2/3 revolutions per infusion system cycle to permit a 0.33 mL fluid displacement every infusion system cycle. The stepper motor then reverses and the plunger returns to home position. This cycle repeats for the duration of fluid administration. Excluding the stepper motor, the plunger drive subsystem includes the following components: ball thrust bearing, screw/coupler assembly, and plunger/support system.

The ball thrust bearing is positioned against the mechanism assembly chassis. As the plunger extends into the cassette diaphragm to displace fluid, the resulting load (due to pumping action and back pressure) is transferred axially through the ball thrust bearing to the mechanism assembly chassis.

The screw/coupler assembly links the motor and the plunger. This assembly includes a flag that passes through an interrupter module. This screw/coupler flag/interrupter module combination is used in conjunction with predetermined factory calibration data to determine the plunger position.

During operation, if the screw/coupler flag passes through the interrupter module at the incorrect time sequence, a motor phase loss is detected.

Section 5

MAINTENANCE AND SERVICE TESTS

A complete maintenance program promotes infusion longevity and trouble-free instrument operation. Such a program should include routine maintenance, periodic maintenance inspection, and following any repair procedure, performance verification testing.

5.1

ROUTINE MAINTENANCE

Routine maintenance consists of basic inspection and cleaning procedures. As a minimum requirement, inspect and clean the infusion pump after each use. In addition, establish a regular cleaning schedule for the infusion pump.

5.1.1

INSPECTING THE INFUSION SYSTEM

Inspect the infusion system periodically for signs of defects such as worn accessories, broken instrument connections, or damaged cables. In addition, inspect the infusion system after repair or during cleaning. Replace any damaged or defective external parts. See [Section 5.2.3, Inspection](#).

5.1.2

CLEANING THE INFUSION SYSTEM

The following procedures are designed to maintain the infusion pump, sustain system longevity, and promote trouble-free instrument operation.

Follow hospital protocol for establishing the infusion pump cleaning schedule.

WARNING: DISCONNECT THE INFUSION SYSTEM FROM AC (MAINS) POWER PRIOR TO CLEANING THE INSTRUMENT. FAILURE TO COMPLY WITH THIS WARNING COULD RESULT IN ELECTRICAL SHOCK.

CAUTION: Do not immerse the infusion system in liquids. Immersion could damage the instrument. Do not allow liquids to enter the infusion system electronics compartment. Do not spray cleaning solutions toward any openings in the infusion system.

CAUTION: Certain cleaning and sanitizing compounds may slowly degrade components made from some plastic materials. Using abrasive cleaners or cleaning solutions not recommended by Hospira may result in product damage and potentially void the product warranty. Do not use compounds containing combinations of isopropyl alcohol and dimethyl benzyl ammonium chloride.

CAUTION: Do not use solvents that are harmful to plastic, such as isopropyl alcohol or acetone, on external surfaces or plastic components. Do not use abrasive cleaners.

CAUTION: To avoid infuser damage, cleaning solutions should be used only as directed in *Table 5-1, Cleaning Solutions*. The disinfecting properties of cleaning solutions vary; consult the manufacturer for specific information

1. Clean the exposed surfaces of the infusion system with a soft, lint-free cloth dampened with one of the cleaning solutions listed in *Table 5-1*, or a mild solution of soapy water.
2. Remove soap residue with clear water. Do not use solvents that are harmful to plastic, such as isopropyl alcohol or acetone. Do not use abrasive cleaners.

| Cleaning Solution | Manufacturer | Preparation |
|--------------------------|--------------------------|---|
| Coverage™ HB | Steris Corporation | Per manufacturer's recommendation |
| Dispatch® | Caltech Industries | Per manufacturer's recommendation |
| Formula C™ | JohnsonDiversey | Per manufacturer's recommendation |
| Manu-Klenz® | Steris Corporation | Per manufacturer's recommendation |
| Precise® | Caltech Industries | Per manufacturer's recommendation |
| Sporicidin® | Sporicidin International | Per manufacturer's recommendation |
| Household bleach | Various | Per hospital procedures; do not exceed one part bleach in ten parts water |

5.1.3

SANITIZING THE INFUSION SYSTEM

Sanitize external surfaces of the infusion system using a cleaner listed in *Table 5-1*.

 **Note:** Not all cleaning solutions are sanitizers. Check product labeling.

CAUTION: Do not sterilize the infusion system using heat, steam, ethylene oxide (ETO), or radiation. These methods may cause the instrument to malfunction.

5.1.4 CLEANING THE BUZZER

Recommended materials are cotton swabs and pure isopropyl alcohol.

Under certain circumstances, residue will build up on the buzzer located on the MCU board. This residue can prevent the buzzer from alarming, but can be easily removed.

To remove any residue, refer to *Figure 5-1, Cleaning the Buzzer*, then proceed as follows:

1. Separate the front and rear enclosures as described in *Section 7.2.5*, leaving the main chassis in the rear enclosure.
2. Inspect the buzzer for any physical damage. If damage is found, discontinue this procedure and [contact Hospira](#).
3. Moisten the cotton swab with the isopropyl alcohol and clean any residue from the entire rear surface of the buzzer.
4. Reassemble the pump in the exact reverse order of disassembly, and perform the PVT in *Section 5.2*.

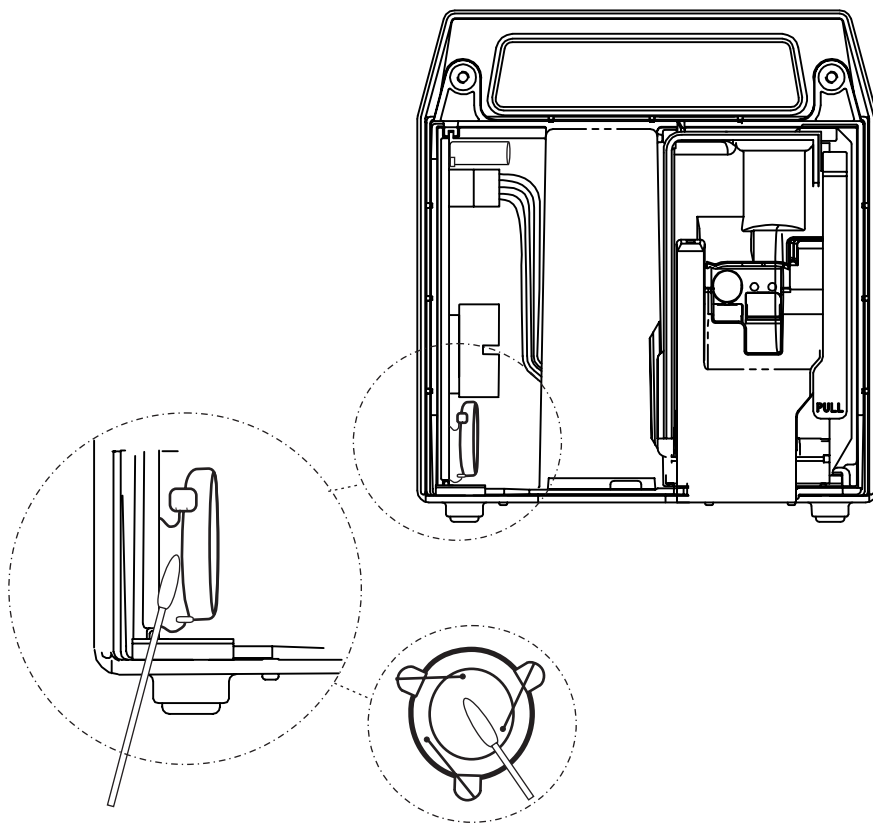

04K01046

Figure 5-1. Cleaning the Buzzer

5.2

PERFORMANCE VERIFICATION TEST

The Performance Verification Test (PVT) consists of the tests described in the following sections. The PVT can be used for diagnostic purposes during the troubleshooting of a malfunctioning infusion system. The PVT should be used for performance verification before an infusion pump is placed back in service after repair. If any malfunction is detected as a result of the PVT, refer to [Table 6-6, PVT Troubleshooting](#).

 **Note:** The PVT must be performed exactly as described in this manual to assure effective and reliable product evaluation information.

5.2.1

EQUIPMENT REQUIRED

The PVT requires the following equipment (or equivalents):

- Graduated cylinder, 25 mL, with 0.2 mL graduations (Type A)
- Sterile water or tap water in two IV bags/containers
- Digital pressure meter, Fluke Biomedical DPM3
- Safety analyzer, Fluke Biomedical 232D
- Three-way stopcock, latex-free, List No. 03233-01 or 03232-01
- Reflux valve (optional)
- Six inch tubing extension, List No. 42362-01 (optional)
- Special cassette with proximal bubble sensor tips removed
- Special cassette with distal bubble sensor tips removed
- LifeShield PlumSet, List No. 1642
- LifeShield secondary set, List No. 11397
- Digital multimeter (DMM), Fluke® 187
- 21-gauge needle, List No. 04492, or 18-gauge blunt cannula
- Battery charger test box (optional)
- Computer with a terminal emulator (optional)
- RS-232 serial communication cable (optional)

5.2.2

ICONS AND ENGLISH LANGUAGE EQUIVALENTS

International infusion systems use icons in displays and labels. Refer to *Figure 5-2, Icons and English Language Equivalents*.

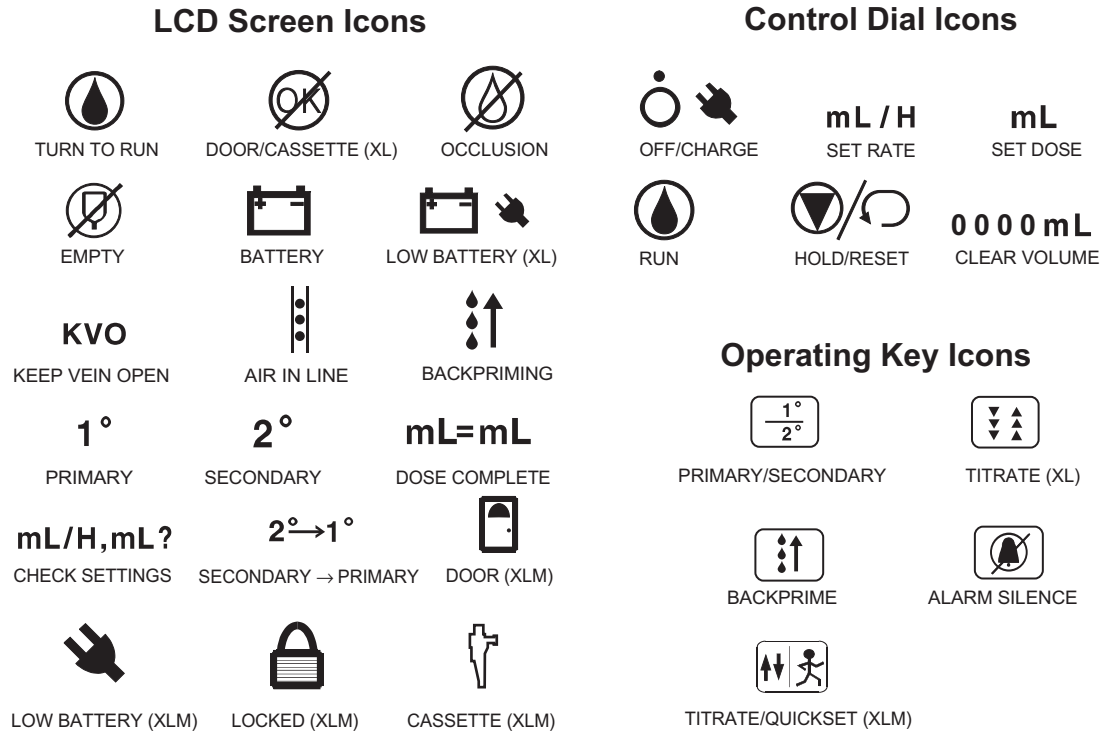

96B03022

Figure 5-2. Icons and English Language Equivalents

5.2.3**INSPECTION**

Inspect the infusion system periodically for signs of defects such as worn accessories or damaged cables. Also, inspect the infusion system after repair or during cleaning. Replace any damaged or defective external parts.

Inspect the following areas for missing and damaged parts:

- Labels
- AC power cord
- Velcro® retainer strap
- Rubber foot pads
- Door assembly, shield, and handle
- Cassette guide spring and roller
- Valve pins, plunger, bubble detectors, and locator pin
- Front panel label
- Control knob and all external screws
- Pole clamp assembly
- Front and rear enclosures
- Battery access cover
- LCD screen
- DataPort connector (XLM with DataPort)

 **Note:** Do not connect DataPort when infusing.

5.2.4**TEST SETUP**

WARNING: A PATIENT SHOULD NEVER BE CONNECTED TO THE INFUSION SYSTEM DURING SYSTEM TESTING.

To set up the infusion system for the PVT, proceed as follows:

1. Confirm the infusion system and appropriate accessories are fully assembled.
2. Hang two sterile water containers at a height of 18 to 24 inches (46 to 60 cm) above the pumping chamber of the infusion system.
3. Connect the infusion system to AC (mains) power. Conduct all tests with the infusion system connected to AC (mains) power unless otherwise specified.
4. Verify the lockout switch is in the UNLOCKED (down) position (XLM only).

5.2.5 SELF TEST

CAUTION: Do not place the infusion system in service if the self test fails.

To perform the self test, refer to *Figure 5-3, Plum XL LCD Test Screens* and *Figure 5-4, Plum XLM LCD Test Screens*, then proceed as follows:

1. Connect the infusion system AC (mains) power cord to a grounded AC (mains) outlet and confirm the AC (mains) power icon (next to the OFF/CHARGE setting) illuminates.
2. Open the door assembly (cassette door) by lifting up on the cassette door handle.
3. Hold a primed cassette by its handle and insert the cassette into the cassette door guides. Do not force the cassette into position.
4. Close the cassette door handle to lock the cassette in place.
5. Turn the control knob to SET RATE to initiate the self test.
6. Verify the following screens display: the LCD test screen; four backward Cs (approximately two seconds); set rate screen.

 **Note:** If the LCD test screen does not match *Figure 5-3* or *Figure 5-4* exactly, contact Hospira.

 **Note:** If an alarm condition occurs during the self test, turn the control knob to OFF/CHARGE and repeat Step 5 and Step 6. If the alarm condition recurs, the message and take corrective action (*see Section 6, Troubleshooting*). Repeat the self test. If the alarm condition recurs, remove the infusion system from service and [contact Hospira](#).

7. Disconnect the infusion system from AC (mains) power and confirm BATTERY displays on the LCD screen.
8. Turn the control knob to OFF/CHARGE and remove the administration set.
9. To allow the battery to charge fully, connect the infusion system to AC (mains) power for a minimum of eight hours with the control knob in the OFF/CHARGE position. Confirm the AC (Mains) power icon illuminates.

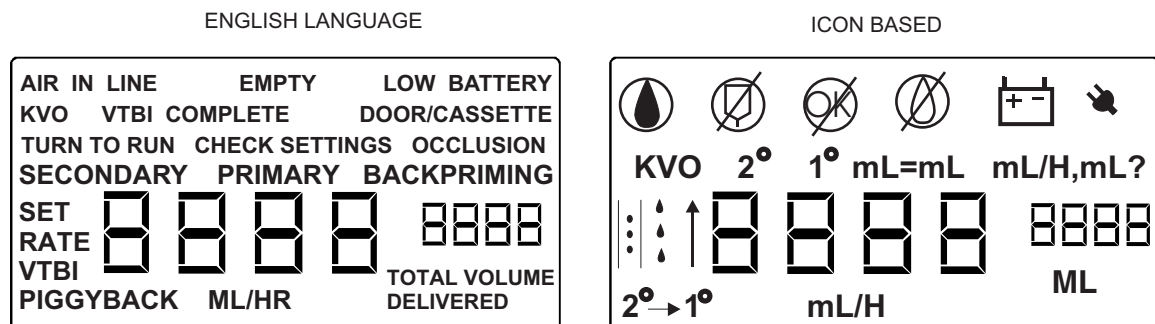

04K01024

Figure 5-3. Plum XL LCD Test Screens

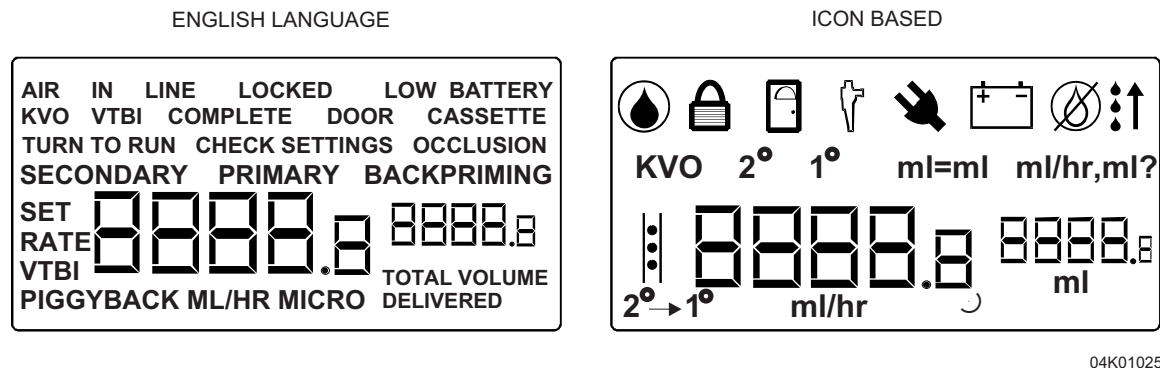

04K01025

Figure 5-4. Plum XLM LCD Test Screens

 **Note:** All LCD screens on international infusion systems are icon-based with the exceptions of country codes 27 and 54.

5.2.6

KEYPAD AND CONTROL KNOB TEST

To perform the keypad and control knob test, proceed as follows:

1. Turn the control knob to SET RATE. Press the following keys to verify that each key activates and the screen responds:
 - [PRI/SEC] toggles screen between PRIMARY and SECONDARY
 - [▲] raises the value of the delivery rate
 - [▼] lowers the value of the delivery rate
 - MICRO legend appears when the rate is lower than 100 mL/hr, and disappears when the rate is above 99.9 mL/hr (XLM)
2. Turn the control knob to SET VTBI. Press the following keys to verify that each key activates and the screen responds:
 - [▲] raises the value of volume delivered
 - [▼] lowers the value of volume delivered
3. Turn the control knob to RUN. Press and hold each key combination simultaneously to verify that each key combination activates and the screen responds:
 - [TITRATE/QUICKSET] and [▲] raises the value of the delivery rate
 - [TITRATE/QUICKSET] and [▼] lowers the value of the delivery rate
4. Turn the control knob to SET RATE. Press the [TITRATE/QUICKSET] key and confirm a quick rate change occurs.
5. Turn the control knob to HOLD/RESET. Press and hold [BACK PRIME] to verify pumping occurs from the primary line up through the secondary inlet port.

5.2.7**OPEN DOOR ALARM TEST**

To perform the open door alarm test, proceed as follows:

1. Close the clamp on the secondary line (to prevent fluid in containers from mixing).
2. Open the cassette door. Verify the DOOR/CASSETTE (XL) or DOOR (XLM) legend appears and an alarm sounds.
3. Press [SILENCE]. Verify the alarm mutes.
4. Close the cassette door and unclamp the secondary line.

5.2.8**ALARM LOUDNESS TEST (XL)**

To perform the alarm loudness test, proceed as follows:

1. Turn the control knob to SET RATE and open the cassette door. Verify the DOOR/CASSETTE legend appears and an alarm sounds.
2. Toggle the audio switch (located on the infusion system bottom) between the high and low settings. Verify two alarm levels sound.
3. Press [SILENCE]. Verify the alarm mutes.
4. Close the cassette door.

5.2.9**ALARM LOUDNESS AND LOCK FUNCTION TESTS (XLM)**

To perform the alarm loudness and lock function tests, proceed as follows:

1. Turn the control knob to SET RATE and open the cassette door. Verify the DOOR legend appears and an alarm sounds.
2. Toggle the audio switch (located on the rear panel) between the high and low settings. Verify two alarm levels sound.
3. Press [SILENCE]. Verify the alarm mutes.
4. Close the cassette door.
5. Turn the control knob to HOLD/RESET, then back to RUN.
6. Press the LOCK button (located on the rear panel). Verify LOCKED appears on the display.
7. Turn the control knob to any other position. Verify the infusion system stops pumping, an alarm sounds, and the display backlight and LOCKED flash.
8. Turn the control knob to RUN. Verify the infusion system starts to pump.
9. Press [SILENCE]. Verify that the alarm condition remains unchanged.
10. Press the LOCK button to clear the alarm condition.

5.2.10

BATTERY LEGEND TEST

To perform the battery legend test, proceed as follows:

1. Disconnect the infusion system from AC (mains) power.
2. Turn the control knob to SET RATE. Verify the line power indicator turns off and the BATTERY legend turns on within five seconds.
3. Reconnect the infusion system to AC (mains) power after the battery legend check.
4. Turn the control knob to OFF/CHARGE.

5.2.11

FREE FLOW TEST

To perform the free flow test, proceed as follows:

1. Insert a primed cassette into the infusion system.
2. Turn the control knob to SET RATE.
3. With the cassette door closed, check the distal end of tubing for fluid flow. Verify a minimal flow of fluid (a few drops maximum) occurs.
4. Open the cassette door and check the distal end of tubing for fluid flow. Verify a minimal flow of fluid (a few drops maximum) occurs.

 **Note:** A small amount of fluid may be expelled from the cassette when opening or closing the door.

5. Close the cassette door and check the distal end of tubing for fluid flow. Verify a minimal flow of fluid (a few drops maximum) occurs.
6. Turn the control knob to OFF/CHARGE.

5.2.12

PROXIMAL OCCLUSION TEST

To perform the proximal occlusion test, proceed as follows:

1. Turn the control knob to SET RATE. Set the rate to a value greater than 40 mL/hr.
2. Turn the control knob to RUN to start pumping fluid.
3. After several pumping cycles, clamp the tubing proximal to the cassette. After drops stop falling through the sight chamber, verify that an occlusion alarm occurs within three pumping cycles.
4. Press [SILENCE] and unclamp the proximal tubing.
5. Turn the control knob to OFF/CHARGE.

5.2.13

DISTAL OCCLUSION TEST

To perform the distal occlusion test, refer to [Figure 5-5, Distal Occlusion Test Setup](#), and proceed as follows:

1. Connect the distal tubing to the DPM through a three-way stopcock as illustrated in [Figure 5-5](#).
 - ✎ **Note:** A reflux valve or six inch tubing extension may be attached between the stopcock and the DPM to keep moisture out of the DPM.
 - ✎ **Note:** The height of the DPM must be 0 to 6 inches (0 to 15 cm) from the midline of the cassette.
2. Turn the control knob to SET RATE.
3. Set the rate to 40 mL/hr.
4. Turn the control knob to SET VTBI.
5. Set the volume to 100 mL.
6. Open the three-way stopcock to air.
7. Turn the control knob to RUN and allow the infusion system to stabilize for one minute. Verify all air is cleared from the tubing.
8. Set the three-way stopcock to measure pressure.
9. Verify the occlusion alarm occurs when DPM indicates 10.0 ± 2 psi (69.0 ± 13.8 kPa).
10. Turn the control knob to HOLD/RESET to clear the occlusion alarm. Open the three-way stopcock to air and disconnect the distal tubing.

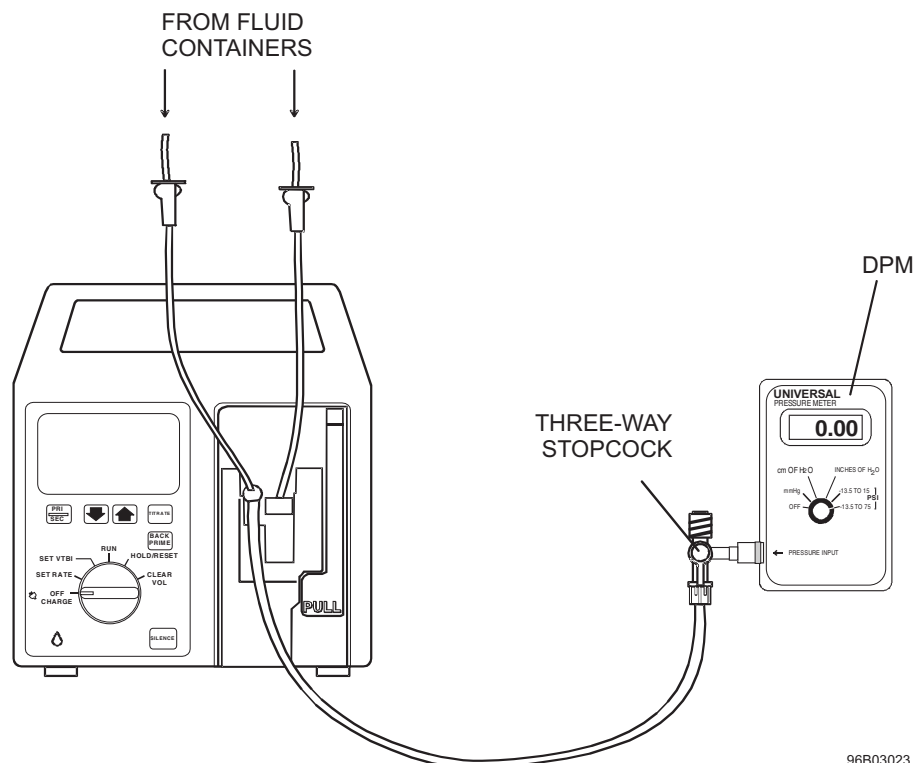

96B03023

Figure 5-5. Distal Occlusion Test Setup

5.2.14**DELIVERY ACCURACY TEST**

 **Note:** Accuracy testing is for informational purposes only, and is not to be used as a re-release test. If there is any concern as to infusion system accuracy, return the infusion system to Hospira Technical Support Operations.

CAUTION: Do not remove the protective cover from the butterfly needle.

To perform the delivery accuracy test, proceed as follows:

1. Attach an 18-gauge cannula, or a 21-gauge needle, to the distal end of the tubing. Verify the fluid container is 18 to 24 inches (46 to 60 cm) above the cassette pumping chamber. Verify all lines are unclamped.
2. Prime the tubing. Verify no air is in the tubing. Place cannula or needle in a 25 mL graduated cylinder.
3. Turn the control knob to SET RATE and set the primary rate to 400 mL/hr.
4. Press [PRI/SEC] to display SECONDARY and set the secondary rate to 400 mL/hr.
5. Turn the control knob to SET VTBI and press [PRI/SEC] to display PRIMARY.
6. Set the primary volume to 10 mL.
7. Press [PRI/SEC] to display SECONDARY and set the secondary volume to 10 mL.
8. Turn the control knob to CLEAR VOL to clear previous value. Verify four beeps sound.
9. Assure the graduated cylinder is dry.
10. Turn the control knob to RUN to start pumping fluid. Verify volume delivered is 20 ± 1 mL. Verify that after the VTBI is complete, the infusion system changes to KVO mode at a rate of 1 mL/hr.
11. Turn the control knob to OFF/CHARGE.
12. Clamp both lines. Remove the distal tubing. Remove the cassette from the infusion system.

5.2.15**EMPTY CONTAINER/AIR-IN-LINE ALARM TEST**

To perform the empty container/air-in-line alarm test, proceed as follows:

1. Install the special cassette marked EMPTY in the infusion system. Confirm the special cassette proximal bubble sensor tips are removed (*see Figure 5-6, Special Cassettes with Bubble Sensor Tips Removed*).
2. Turn the control knob to SET VTBI.
3. Set the volume to 100 mL.
4. Turn the control knob to RUN to start pumping. Verify that within three pumping cycles the audible alarm sounds and the AIR-IN-LINE and BACKPRIMING legends display.
5. Turn the control knob to HOLD/RESET.
6. Open the cassette door and remove the cassette.
7. Install the special cassette marked AIR in the infusion system. Confirm the special cassette distal bubble sensor tips are removed (*see Figure 5-6*).
8. Turn the control knob to RUN to start pumping. Verify that within three pumping cycles the alarm sounds and the AIR-IN-LINE legend displays.

9. Turn the control knob to HOLD/RESET.
10. Open the cassette door and remove the cassette.

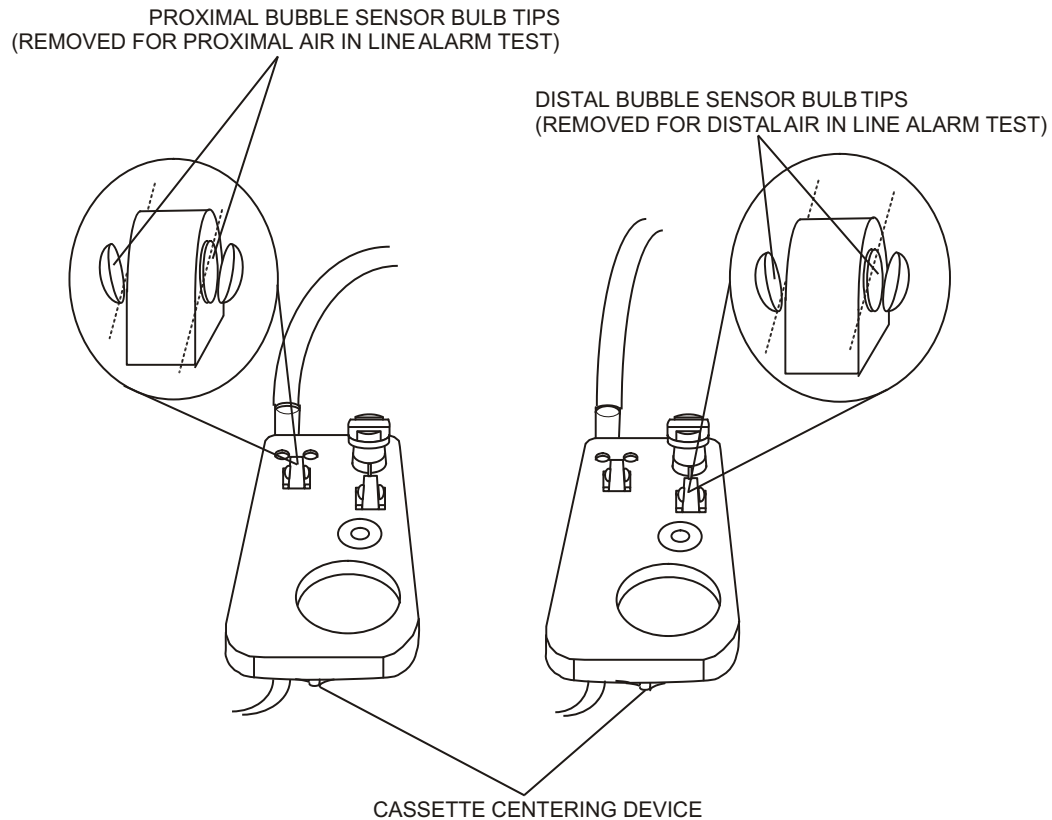

04K01027

Figure 5-6. Special Cassettes with Bubble Sensor Tips Removed

5.2.16

ELECTRICAL SAFETY TEST

To perform the electrical safety test, proceed as follows:

1. Connect the infusion system AC (mains) power cord to a safety analyzer.
2. Connect the safety analyzer ground lead to the infusion system ground test-point screw located on the rear of the infusion system.
3. Check the leakage current with the safety analyzer. Leakage current must not exceed 100 microamperes (μA) (AC RMS).
4. Measure the resistance of the AC (mains) connector ground lug with the safety analyzer. Resistance should not exceed 0.1Ω .

5.2.17

END OF PERFORMANCE VERIFICATION TEST

If all tests have been successful, proceed as follows:

1. Clear the dose history.
2. Reset the infusion system to the original configuration.
3. Return the infusion system to service.

 **Note:** If any tests fail, refer to [Section 6, Troubleshooting](#), or [contact Hospira Technical Support Operations](#).

5.3

PERIODIC MAINTENANCE INSPECTION

Periodic maintenance inspections should be performed per hospital procedures for compliance to accreditation requirements. It is recommended that JCAHO and/or hospital protocol be followed for establishing an infusion pump periodic maintenance inspection schedule. Product specifications for this inspection are listed in [Section 8, Specifications](#). To perform the periodic maintenance inspection, complete the performance verification test in [Section 5.2](#).

5.4

BATTERY OPERATION OVERVIEW

The infusion system is intended to operate on battery power on an exception basis only, such as emergency backup or temporary portable operation. Examples of emergency backup include AC (mains) power failure or inadvertent disconnection of the AC (mains) power cord. An instance of temporary portable operation includes patient transfer from one location to another.

The infusion system should be connected to AC (mains) power whenever possible to allow the battery to remain fully charged. The infusion system line power indicator disappears and the BATTERY legend appears when the infusion system is operating on battery power.

Factors that most commonly affect battery life are the depth and frequency of discharge and the length of the recharge period. As a general rule, the more often the battery is discharged and recharged the sooner it will need replacement. The primary cause of damage is leaving the battery in a less than fully charged state for any period of time. Battery damage can occur in a matter of hours and cause a permanent loss of battery capacity. The amount of lost capacity depends on the degree of discharge, the storage temperature, and the length of time the battery was stored in a discharged state.

 **Note:** A permanently damaged battery cannot be recharged to full capacity.

When the battery discharges below the acceptable level while the infusion system is operating, the alarm sounds and the LOW BATTERY message displays. Although it is not recommended to continue operating the infusion system on battery power at this point, the battery will continue providing power until discharged. At this point, the infusion system enters the battery discharged mode and operation ceases.

CAUTION: As soon as the **LOW BATTERY** alarm occurs, connect the infusion system to AC (mains) power.

Recharging occurs any time the infusion system is connected to AC (mains) power. It is recommended that the infusion system be connected to AC (mains) power whenever practicable to maximize available battery charge during transport or ambulation. The power switch does not have to be on for the battery to recharge. Recharging while the infusion system is operating is rate dependent.

 **Note:** The infusion system should be operated on battery power for six continuous hours at least once every six months for optimum battery performance and life.

5.4.1

BATTERY CHARGER CURRENT TEST (OPTIONAL)

To perform the battery charger current test, refer to *Figure 5-7, Battery Charger Current Test Configuration*, then proceed as follows:

 **Note:** Make certain the battery is in good condition and charged. If necessary, use a second battery for this test.

1. Disconnect the infusion system from AC (mains) power. Remove the battery access cover and disconnect the battery.
2. Connect the battery charger test circuit as illustrated in *Figure 5-7*. Make certain switch S1 is in the off position.
3. Connect the infusion system to AC (mains) power and allow 20 seconds for the current to stabilize. Read the current on the current meter.
4. Compare the measured current to the minimum and maximum values in *Table 5-2, Battery Charger Current Test Parameters*.

 **Note:** If the reading is too low, the battery may be fully charged. Close switch S1; repeat Step 3 and verify per *Table 5-2*.

5. Disconnect the infusion system from AC (mains) power. Remove the battery charger test circuit. Reconnect the battery to the infusion system. Replace the battery access cover and secure.

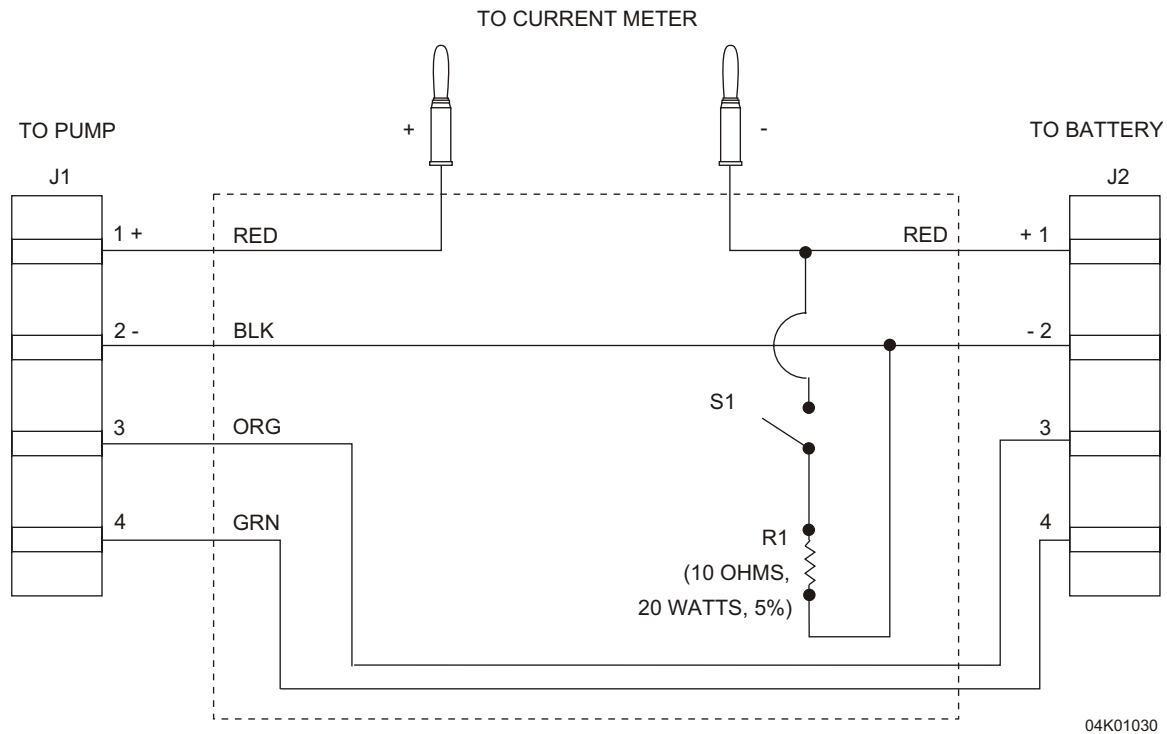

Figure 5-7. Battery Charger Current Test Configuration

| Battery Type | Jumper between Pins 3 and 4 | Minimum Value | Maximum Value |
|--------------|-----------------------------|---------------|---------------|
| 1 | No | 1.0 Amps | 1.4 Amps |
| 2 | Yes | 0.64 Amps | 0.92 Amps |

5.5 DATAPORT CONNECTION AND GROUND CONTINUITY TEST (OPTIONAL)

To perform the DataPort connection and continuity test, refer to [Figure 5-8, DataPort Connector](#), then proceed as follows:

1. Confirm the infusion system and appropriate accessories are fully assembled.
2. Measure the continuity with a DMM between the left lug of the DataPort connector and the ground test point on the lower left corner of the rear case. The resistance should not exceed 1 ohm.
3. Connect the infusion system to AC (mains) power.
4. Turn the control knob to the SET RATE position.
5. Measure the voltage on the DataPort connector between pin 10 (CTS) and pin 9 (COMGND). Verify the voltage is 12.25 ± 0.25 VDC.
6. Turn the control knob to the OFF position.
7. Connect the infusion system to an available RS-232 serial port in the host computer.

8. Set the terminal emulator in the host computer with the following parameters:
 - 1200 baud, 8 data bits, parity none, stop bits 1
 - Echo typed character locally
9. Turn the control knob to the SET RATE position.
10. Type in the following commands from the terminal emulator:
T@0;I45A4<CR> (where "<CR>" = Carriage Return)

 **Note:** Commands are case sensitive.

11. Verify the response message is in the following format:
FXX;YYYY;RZZZZ (where "XX = Hard ID", "YYYY = Soft ID", "ZZZZ = CRC")
12. Turn the control knob to the OFF position.
13. Disconnect the infusion system from the RS-232 cable DataPort Connector.

 **Note:** Do not connect DataPort when infusing.

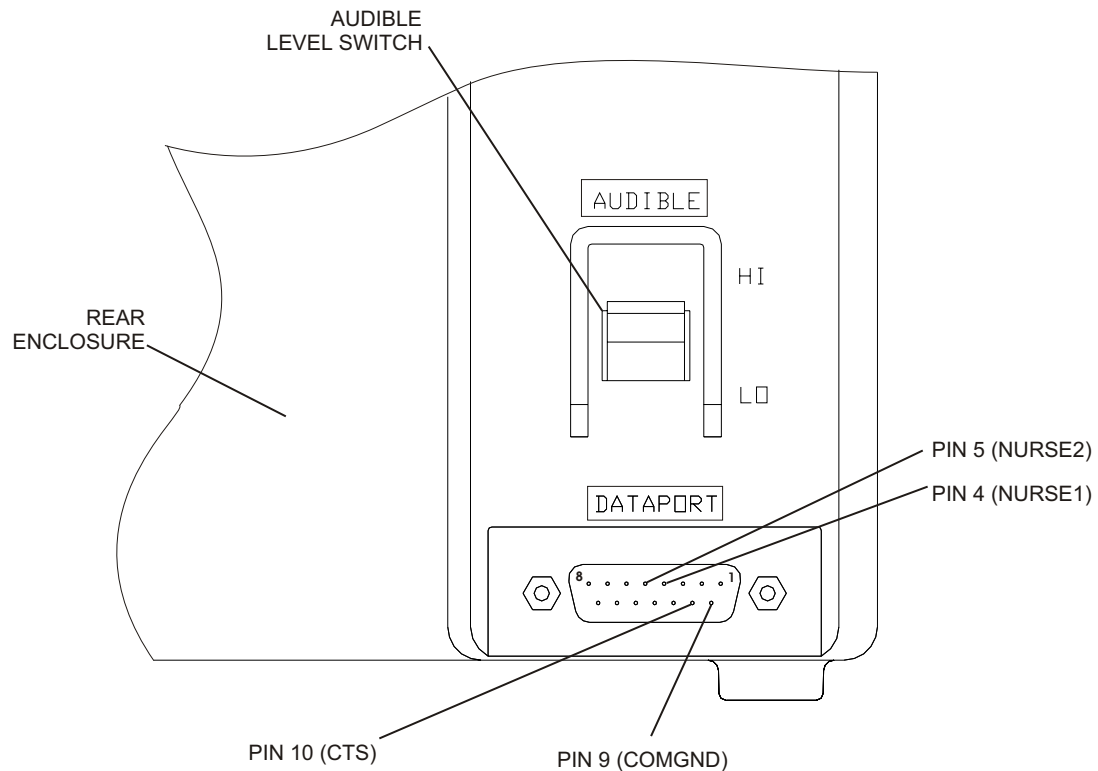

04K01029

Figure 5-8. DataPort Connector

5.6

NURSE CALL FUNCTION TEST (OPTIONAL)

To perform the nurse call function test, refer to [Figure 5-8](#), then proceed as follows:

1. Confirm the infusion system and appropriate accessories are fully assembled.
2. Turn the control knob to the SET RATE position. Set the rate to a value greater than 40 mL/hr.
3. Turn the control knob to SET VTBI position. Set volume to 100 mL.
4. Turn the control knob to RUN to start pumping fluid.
5. Measure the continuity between pin 4 and pin 5 with a DMM. Verify there is an open circuit between the two pins.
6. After several pumping cycles, clamp the tubing proximal to the cassette. After drops stop falling in the sight chamber, verify an occlusion alarm occurs within three pumping cycles.
7. Measure the continuity between pin 4 and pin 5 with the DMM. Verify there is a closed circuit between the two pins.
8. Press [SILENCE] and unclamp the proximal tubing.
9. Verify the continuity between pin 4 and pin 5 changes back to an open circuit once [SILENCE] is pressed.
10. Turn the control knob to OFF/CHARGE.

 **Note:** The nurse call alarm is not available in IEC compliant infusers. 

Section 6

TROUBLESHOOTING

This section contains information on obtaining technical assistance, and alarm messages and error codes for the infusion system.

6.1

TECHNICAL ASSISTANCE

For technical assistance, product return authorization, and to order parts, accessories, or manuals within the United States, [contact Hospira Technical Support Operations](#).

1-800-241-4002

For additional technical assistance, technical training, and product information, visit the website at www.hospira.com.

Send all authorized, prepaid returns within the United States to the following address:

**Hospira, Inc.
Technical Support Operations
755 Jarvis Drive
Morgan Hill, California 95037**

For technical assistance, product return authorization, and to order parts, accessories, or manuals from outside the United States, contact the nearest Hospira sales office.

6.2

ALARM MESSAGES AND ERROR CODES

Under most alarm conditions the infusion system ceases normal operation, generates an audible alarm, and displays an alarm message or error code on the LCD screen.

There are two types of alarm conditions:

- alarm codes that can be cleared by the operator
- error codes that require qualified service personnel

See [Table 6-1, Operational Alarm Messages and Corrective Actions](#), and [Table 6-2, Error Codes Requiring Technical Service](#).

6.2.1

OPERATIONAL ALARM MESSAGES

Table 6-1 lists infusion system alarm codes that can be cleared by the operator. Also listed in *Table 6-1* are the alarm messages, descriptions, possible causes, and corrective actions.

Note: Operational alarm messages are displayed on the LCD screen. Associated error codes are displayed in the alarm history (*see Section 6.2.3.1, Alarm History*).



| Table 6-1. Operational Alarm Messages and Corrective Actions | | | | |
|--|---|--|--|---|
| Error Code | Alarm Message | Description | Possible Cause | Corrective Action |
| 01-1 | OCCLUSION  | Distal occlusion alarm | Distal pressure above 10 psi for five seconds | Unkink tubing, check IV site, or replace administration set If condition recurs, contact Hospira |
| 01-2 | | Distal occlusion alarm | Distal pressure above 10 psi for two plunger strokes | |
| 01-3 | | Distal occlusion alarm | Distal pressure above 13 psi | |
| 01-4 | | Distal occlusion alarm | Excessive distal pressure during the valve leak test | |
| 03-1 | | Proximal occlusion alarm | Clamp closed; tubing kinked; possible occluded tubing; defective administration set; or defective pressure circuit | |
| 03-2 | | Proximal occlusion on secondary during backpriming | | |
| 06-1 | AIR IN LINE BACKPRIMING  | Air detected in cassette Proximal air-in-line | 1000 µL of air has entered the cassette since last initialization | Backprime to expel air |
| 07-1 | AIR IN LINE  | Distal air-in-line | 100 µL bolus of air detected at distal sensor | Remove and reprime cassette |
| 07-2 | | Distal air-in-line | 260 µL of air detected in the last 2.6 mL of fluid delivered | Remove and reprime cassette |

Table 6-1. Operational Alarm Messages and Corrective Actions





| Error Code | Alarm Message | Description | Possible Cause | Corrective Action |
|------------|---|---|--|---|
| 08-1 | AIR IN LINE BACKPRIMING  | Empty container alarm | 500 µL of air detected entering the cassette in the last two intake strokes | Change container and backprime to expel air |
| 10-1 | CHECK SETTINGS mL/H=mL? | Check settings alarm | Rate and VTBI settings not correct | Turn control knob to SET RATE or SET VTBI to check settings or enter values |
| 11-1 | TURN TO RUN  | Turn to run alarm | Rotary control knob not in OFF/CHARGE or RUN position, or no key is pressed for five minutes | Turn control knob to RUN, OFF/CHARGE, or HOLD/RESET |
| 12-1 | VTBI COMPLETE mL=mL | Primary VTBI complete alarm | The VTBI for the primary channel has been delivered | Discontinue infusion, or change container and program new VTBI setting |
| 12-2 | | Secondary VTBI complete alarm | The VTBI for the secondary channel has been delivered | |
| 13-1 | CASSETTE DOOR/CASSETTE (XL only)  or  | Input/output valve leak test failure | Defective administration set | Turn control knob to OFF/CHARGE, open and close cassette door, then restart If condition recurs, replace administration set Turn control knob to OFF/CHARGE or HOLD/RESET, reprime cassette and restart |
| 13-2 | | Primary/secondary valve leak test failure | Cassette improperly loaded or improperly primed | |
| 13-3 | | Valve leak test failure due to excessive signal noise | Fluid spillage around valve pins | |

Table 6-1. Operational Alarm Messages and Corrective Actions





| Error Code | Alarm Message | Description | Possible Cause | Corrective Action |
|-------------------|---|---|---|--|
| 14-1 | LOCKED  | Lock violation alarm | Control knob position changed while in LOCKED mode | Press LOCK button and reset settings |
| 15-1 | None The device does not communicate to the host computer | UART test failure | The UART loop-back test during power-up failed | Replace MCU PWA (Section 7.2.9.1) |
| 15-2 | None The device does not communicate to the host computer | Excessively frequent UART interrupts | The MCU does not have enough time to process UART hardware due to UART hardware failure | Replace MCU PWA (Section 7.2.9.1) |
| 15-3 | None The device does not communicate to the host computer | The UART receiver buffer has overflowed | The MCU does not have enough time to process the received data due to UART hardware failure | Replace MCU PWA (Section 7.2.9.1) |
| 16-1 | TURN TO RUN  | Control knob in between valid states for five minutes | Control knob not in OFF/CHARGE or RUN position | Turn control knob to RUN, OFF/CHARGE, or HOLD/RESET position |
| | | | Defective control knob assembly | Replace control knob assembly (Section 7.2.7.3) |
| 17-1 | LOW BATTERY  | Low battery alarm | Low battery | Connect to AC power or turn control knob to HOLD/RESET, then to RUN |
| 17-2 | | Low battery re-alarms after 15 minutes | Low battery | Connect to AC power or turn control knob to HOLD/RESET, then to RUN |
| 18-1 | LOW BATTERY  | Discharged battery alarm | Fully discharged battery | Connect to AC power, turn control knob to OFF/CHARGE, or replace the battery |

Table 6-1. Operational Alarm Messages and Corrective Actions

| Error Code | Alarm Message | Description | Possible Cause | Corrective Action |
|-------------------|--|--|------------------------------|--|
| 18-2 | Display blank | Infusion system shutdown one minute after discharged battery alarm | Fully discharged battery | Connect to AC power, turn control knob to OFF/CHARGE, or replace the battery |
| 19-1 | DOOR DOOR/CASSETTE (XL only)  or  | Door open | Cassette door open | Turn control knob to OFF/CHARGE, or close cassette door |
| | | | Cassette not seated properly | Reseat cassette |

6.2.2

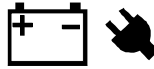
ERROR CODES REQUIRING TECHNICAL SERVICE

Table 6-2 lists infusion system error codes that require technical service. Also listed in *Table 6-2* are the malfunction descriptions, possible causes, and corrective actions.

Note: The error code is displayed on the LCD screen. Associated malfunction descriptions are not displayed. If reference to alarm history is required, see [Section 6.2.3.1](#).

| Table 6-2. Error Codes Requiring Technical Service | | | |
|---|---|---|---|
| Error Code | Malfunction Description | Possible Cause | Corrective Action |
| 20-1 | Stack overflow | MCU RAM error | Replace MCU PWA (Section 7.2.9.1) |
| 21-1 | Critical data checksum failure at start up | MCU RAM error | Replace MCU PWA (Section 7.2.9.1) If condition recurs, contact Hospira |
| | | Nonvolatile memory error | |
| 21-2 | Critical data checksum failure during operation | MCU RAM error | Replace MCU PWA (Section 7.2.9.1) |
| 21-3 | Checksum of operational parameters failure at startup | MCU RAM error | |
| 21-4 | Checksum of operational parameters failure during operation | MCU RAM error | |
| 29-1 | ROM checksum failure at startup | MCU ROM error | |
| 29-2 | ROM checksum failure during operation | MCU ROM error | Replace MCU PWA (Section 7.2.9.1) |
| 29-3 | ROM checksum test not being performed | MCU execution error | |
| 34-1 | EEPROM read/write test failure | Decode circuit failure | |
| | | EEPROM chip failure | |
| 35-1 | Critical RAM values found incorrect | MCU RAM error | Replace MCU PWA (Section 7.2.9.1) Replace display PWA (Section 7.2.7.1) |
| 41-1 | LCD driver chip test failure | Decode circuit failure | |
| | | Driver chip failure | |
| 44-1 44-2 | Audio BUZZER signal out of range | Audio buzzer or circuit failure | Replace MCU PWA (Section 7.2.9.1) Check fuse F3 on power supply PWA; replace fuse, if defective (Section 7.2.8.1) If condition recurs, contact Hospira |
| | | ADC on MCU chip not functioning properly or ADC reference voltage not correct | |

Table 6-2. Error Codes Requiring Technical Service

| Error Code | Malfunction Description | Possible Cause | Corrective Action |
|-------------------|---------------------------------------|---|---|
| 45-1 | [PRI/SEC] key stuck in ON position | Switch S1 on display PWA shorted or stuck | Replace display PWA (Section 7.2.7.1) |
| | | Front panel key stuck | Replace key (Section 7.2.7.2) Replace front enclosure assembly (Section 7.2.6) |
| 45-2 | [UP ARROW] key stuck in ON position | Switch S3 on display PWA shorted or stuck | Replace display PWA (Section 7.2.7.1) |
| | | Front panel key stuck | Replace key (Section 7.2.7.2) Replace front enclosure assembly (Section 7.2.6) |
| 45-3 | [DOWN ARROW] key stuck in ON position | Switch S2 on display PWA shorted or stuck | Replace display PWA (Section 7.2.7.1) |
| | | Front panel key stuck | Replace key (Section 7.2.7.2) Replace front enclosure assembly (Section 7.2.6) |
| 45-4 | [TITRATE] key stuck in ON position | Switch S4 on display PWA shorted or stuck | Replace display PWA (Section 7.2.7.1) |
| | | Front panel key stuck | Replace key (Section 7.2.7.2) Replace front enclosure assembly (Section 7.2.6) |
| 45-5 | [BACKPRIME] key stuck in ON position | Switch S5 on display PWA shorted or stuck | Replace display PWA (Section 7.2.7.1) |
| | | Front panel key stuck | Replace key (Section 7.2.7.2) Replace front enclosure assembly (Section 7.2.6) |
| 45-6 | [SILENCE] key stuck in ON position | Switch S6 on display PWA shorted or stuck | Replace display PWA (Section 7.2.7.1) |
| | | Front panel key stuck | Replace key (Section 7.2.7.2) Replace front enclosure assembly (Section 7.2.6) |
| 59-1 | Valve motor moving at the wrong time | Position sensor failure | Replace mechanism assembly (Section 7.2.9.2) |
| | | Motor drive circuit failure | Replace MCU PWA (Section 7.2.9.1) |

Table 6-2. Error Codes Requiring Technical Service

| Error Code | Malfunction Description | Possible Cause | Corrective Action |
|-------------------|---|---|---|
| 60-1 | Plunger motor position flag stuck high during re-synchronization | Position sensor failure | Replace mechanism assembly (Section 7.2.9.2) |
| | | Plunger motor not moving | Check connection at J7 on MCU PWA If condition recurs, contact Hospira |
| 60-2 | Plunger motor position signal is continuous low during re-synchronization | Position sensor failure | Replace mechanism assembly (Section 7.2.9.2) |
| | | Enable circuit failed | Check connection at J7 on MCU PWA If condition recurs, contact Hospira |
| | | Plunger motor not moving | |
| 61-1 | Input/output motor position flag is continuous high during re-synchronization | Position sensor failure | Replace mechanism assembly (Section 7.2.9.2) |
| | | Input/output motor not moving | Check connection at J8 on MCU PWA If condition recurs, contact Hospira |
| 61-2 | Input/output motor position signal is continuous low during re-synchronization | Position sensor failure | Replace mechanism assembly (Section 7.2.9.2) |
| | | Enable circuit failure | Check connection at J8 on MCU PWA If condition recurs, contact Hospira |
| | | Input/output motor not moving | |
| 62-1 | Primary/secondary motor position flag is continuous high during re-synchronization | Position sensor failure | Replace mechanism assembly (Section 7.2.9.2) |
| | | Primary/secondary motor not moving | Check connection at J9 on MCU PWA If condition recurs, contact Hospira |
| 62-2 | Primary/secondary motor position signal is continuous low during re-synchronization | Position sensor failure | Replace mechanism assembly (Section 7.2.9.2) |
| | | Enable circuit failure | Check connection at J9 on MCU PWA If condition recurs, contact Hospira |
| | | Primary/secondary motor not moving | |
| 63-1 | Plunger motor phase loss | Plunger motor does not have enough torque | Replace mechanism assembly (Section 7.2.9.2) |
| | | Mechanical assembly failure | |

Table 6-2. Error Codes Requiring Technical Service

| Error Code | Malfunction Description | Possible Cause | Corrective Action |
|-------------------|---|---|--|
| 64-1 | Input/output motor phase loss | Input/output motor does not have enough torque | Replace mechanism assembly (Section 7.2.9.2) |
| | | Mechanical breakage in mechanism | |
| 65-1 | Primary/secondary motor phase loss | Primary/secondary motor does not have enough torque | Replace mechanism assembly (Section 7.2.9.2) |
| | | Mechanical breakage in mechanism | |
| 71-1 | Internal timers out of tolerance | Internal MCU PWA malfunction | Replace MCU PWA (Section 7.2.9.1) |
| 73-1 | +2.5-VDC ADC reference voltage out of tolerance | +2.5-VDC reference to ADC missing or bad | Check fuse F3 on power supply PWA; replace fuse, if defective (Section 7.2.8.1) If condition recurs, contact Hospira |
| | | +3.75-VDC reference to ADC missing or bad | Check fuse F3 on power supply PWA; replace fuse, if defective (Section 7.2.8.1) If condition recurs, contact Hospira |
| | | ADC failure | Replace MCU PWA (Section 7.2.9.1) |
| 73-2 | +5-VDC ADC reference voltage out of tolerance | +2.5-VDC reference to ADC missing or bad | Check fuse F3 on power supply PWA; replace fuse, if defective (Section 7.2.8.1) If condition recurs, contact Hospira |
| | | +3.75-VDC reference to ADC missing or bad | Check fuse F3 on power supply PWA; replace fuse, if defective (Section 7.2.8.1) If condition recurs, contact Hospira |
| | | ADC converter failure | Replace MCU PWA (Section 7.2.9.1) |
| 74-1 | Air sensor self test failure; signal seen when sensors disabled | Air sensor or circuitry failure | Replace mechanism assembly (Section 7.2.9.2) |
| 74-4 | Proximal air sensor signal too high | Air sensor or circuitry failure | Replace mechanism assembly (Section 7.2.9.2) |
| 74-5 | Distal air sensor signal too high | Air sensor or circuitry failure | Replace mechanism assembly (Section 7.2.9.2) |

Table 6-2. Error Codes Requiring Technical Service

| Error Code | Malfunction Description | Possible Cause | Corrective Action |
|--------------------------|--|--|---|
| 81-1 | Power supply PWA signals HKDC and DHKDC do not match | Power supply PWA failure | Replace power supply PWA (Section 7.2.8.2) |
| | | Failure in conditioning circuit on MCU PWA | Replace MCU PWA (Section 7.2.9.1) |
| 81-2 | Power supply PWA signal HKDC out of tolerance | Power supply PWA failure | Replace power supply PWA (Section 7.2.8.2) |
| | | Failure of conditioning circuit on MCU PWA | Replace MCU PWA (Section 7.2.9.1) |
| 81-3 | Power supply PWA signal VMOT out of tolerance when AC power is applied | Power supply PWA failure | Replace power supply PWA (Section 7.2.8.2) |
| 81-4 | Motor voltage drops too much when motor is energized | Power supply PWA failure | Replace power supply PWA (Section 7.2.8.2) If condition recurs, contact Hospira |
| | | Motor drawing excessive current | |
| 90-1 | Calibration data in EEPROM checksum failure | EEPROM internal failure | Contact Hospira |
| | | EEPROM decode circuitry failure | |
| 94-1 | Control knob signal seen when disabled | Control knob circuitry failure | Replace display PWA (Section 7.2.7.1) |
| 94-2 | Illegal control knob signal seen | Control knob circuitry failure | Replace display PWA (Section 7.2.7.1) |
| 94-4 | Reed switch does not match control knob signal | Control knob circuitry failure | Replace display PWA (Section 7.2.7.1) |
| | | Reed switch failure | |
| 95-1 | Primary valve pin not moving | Pin detect circuitry failure | Replace mechanism assembly (Section 7.2.9.2) |
| | | Valve pin not present | |
| | | Valve pin not moving | |
| 95-2 | Secondary valve pin not moving | Pin detect circuitry failure | Replace mechanism assembly (Section 7.2.9.2) |
| | | Valve pin not present | |
| | | Valve pin not moving | |
| 96-1 | UART test failure during operation | UART failure | Replace MCU PWA (Section 7.2.9.1) |
| 99-1 through 99-6 | Failure of one of the internal software self-tests | MCU internal failure | Replace MCU PWA (Section 7.2.9.1) |

6.2.3

SERVICE MODE

The service mode provides diagnostic and repair service information. On the Plum XL, the service mode is accessed by simultaneously pressing and holding the [TITRATE] and [SILENCE] keys while turning the control knob from the OFF/CHARGE position.

On the Plum XLM, the service mode is accessed by simultaneously pressing and holding the [TITRATE/QUICKSET] and [SILENCE] keys while turning the control knob from the OFF/CHARGE position. These keys must be pressed until the end of the self-test sequence, at which time normal infusion system operation is disabled and the service mode is accessed.

The following sections briefly describe the service mode-particular alarm history, software revision number, run-time, battery run-time, and parameter programming functions. [Table 6-3, Service Mode Control Knob Settings](#), lists the infusion system control knob settings used during the service mode and provides functional differences for each control knob setting.

| Table 6-3. Service Mode Control Knob Settings | |
|---|-------------------------------|
| Control Knob Setting | Service Mode Information |
| SET RATE | Alarm history |
| SET VTBI | Software revision number |
| RUN | Run time and battery run time |
| HOLD/RESET (XLM with DataPort) | Parameter programming |

6.2.3.1

ALARM HISTORY

When the infusion system is in service mode and the control knob is turned to the SET RATE position, the alarm history can be viewed. In viewing the alarm history list, large digits indicate an alarm error number (Er01, Er02, Er03) and small digits indicate a four-digit alarm code. If there are no entries in the alarm history, the large digits indicate **Er**, and the small digits indicate ----.

The infusion system [▲] and [▼] keys are used to scroll through the alarm history. The first entry displayed is the most recent alarm. To view a previous alarm, press the [▲] key. The large numerals increment to indicate the order of alarms. Pressing the [▲] key has no effect when the end of the alarm history is reached. To review the entries, press the [▼] key.

When preventive maintenance is performed on the infusion system, it may be desirable to clear the alarm history. Clear the alarm history by simultaneously pressing and holding the [PRI/SEC] key and the [BACKPRIME] key for four seconds. The small digits flash and an audible tone sounds four times at a once-per-second rate. After four seconds, the alarm history list is cleared.

6.2.3.2**SOFTWARE REVISION NUMBER**

When the infusion system is in service mode and the control knob is set to the SET VTBI position, the software revision number can be viewed. The decimal point does not appear in the software revision number display, but is implied after the first digit. For example, if the display shows 105, the software revision number is 1.05. The software revision number may be necessary when contacting Hospira.

6.2.3.3**RUN TIME AND BATTERY RUN TIME**

When the infusion system is in service mode and the control knob is set to the RUN position, the run time and battery run time can be viewed. In the run time and battery run time display, large digits indicate the total infusion system run time in tens of hours and the small digits indicate the battery run time in tens of hours. For example: if the large digits indicate 245 and the small digits indicate 79, the infusion system has been operated for a total of 2,450 hours and has also been operated on battery for 790 of those 2,450 hours.

When replacing the battery, it may be desirable to clear the battery run time. To clear the battery run time, simultaneously press and hold the [PRI/SEC] key and the [BACKPRIME] key for four seconds. The small digits flash and an audible tone sounds four times at a once-per-second rate. After four seconds, the battery run time is cleared. The total infusion system time cannot be cleared.

6.2.3.4**PARAMETER PROGRAMMING (XLM WITH DATAPORT)**

When the infusion system is in service mode and the control knob is set to HOLD/RESET, three sub-modes can be viewed and changed. Each of these three sub-modes are used to change the value of an operational parameter of the infusion system as shown in [Table 6-4, Sub-Modes of Parameter Programming](#).

The first sub-mode (communication selection) is the default sub-mode of parameter programming. Subsequently pressing the [BACKPRIME] key will change it to the second sub-mode (soft ID), the third sub-mode (channel label), then to the first sub-mode. Within a sub-mode, the small digits indicate its index while the large digits indicate the current value of the parameter to be viewed and programmed.

| Sub-Mode Name | Purpose | Sub-Mode Index |
|-------------------------|--|-----------------------|
| Communication Selection | To select the communication with the host computer | 1 |
| Soft ID | To enter the soft ID of the infusion system | 2 |
| Channel Label | To enter the channel label of the infusion system | 3 |

6.2.3.4.1**Communication Selection**

The value of the communication selection can be either 0 or 1. Value 0 means that the communication circuitry of the infusion system will be powered up when the device is operating on AC (mains) power, and will be powered down when the infusion system is operating on battery. Value 1 means the communication circuitry will be powered up regardless of the power supply type. [Table 6-5, Communication Circuitry Selections](#), shows how the communication selection and the power supply determine the power of the communication circuitry. Use the [▲] and [▼] keys to toggle the value between 0 and 1.

| Selection | AC Operation | Battery Operation |
|------------------|----------------------------------|------------------------------------|
| 0 | Power up communication circuitry | Power down communication circuitry |
| 1 | Power up communication circuitry | Power up communication circuitry |

6.2.3.4.2**Soft ID**

The large digits indicate the current value of the soft ID. The range is between 0 and 9999.

Use the [▲] and [▼] keys to change the value. The [▲] key increases the value up to, but does not exceed, 9999. The [▼] key decreases the value down to, but does not pass, 0.

6.2.3.4.3**Channel Label**

The first two of the large digits indicate the current hard ID if the setting of the junction box has no parity error. If there is no entry, two dashes will be displayed. The third digit displays a dash. The fourth digit indicates the current value of the channel label. The fourth digit should be 0 for the single channel version of the infusion system (i.e., XLM with DataPort).

Simultaneously press and hold the [TITRATE/QUICKSET] and [SILENCE] keys for two seconds to change the value. Use the [▲] key to increase the value and [▼] key to decrease the value.

6.3

TROUBLESHOOTING PROCEDURES

Table 6-6, PVT Troubleshooting, describes failures that may be detected during the Performance Verification Test (PVT). If an error code displays, see [Section 6.2](#).

| Table 6-6. PVT Troubleshooting | | |
|---|--|--|
| Test Failures | Possible Causes | Corrective Actions |
| Self test Section 5.2.5 | Cassette not properly installed | Reprime and re-insert cassette |
| | Defective MCU PWA | Replace MCU PWA |
| Keypad and control knob test Section 5.2.6 | Defective display PWA or ribbon cable | Replace display PWA or ribbon cable |
| | Defective control knob | Replace control knob |
| Open door alarm test Section 5.2.7 | Cassette door open | Close cassette door |
| | Cassette not properly seated | Reseat cassette |
| | Defective sensor PWA | Replace mechanism assembly |
| | Defective mechanism assembly | Replace mechanism assembly |
| | Defective MCU PWA or ribbon cable | Replace MCU PWA or ribbon cable |
| Alarm loudness test Section 5.2.8 Section 5.2.9 | Corrosive buildup on bottom surface of the buzzer located on the MCU board | Clean buzzer <i>(see Section 5.1.4)</i> |
| | Defective MCU PWA | Replace MCU PWA |
| | Defective power supply PWA | Replace power supply PWA |
| Battery legend test Section 5.2.10 | Defective fuse | Replace fuse |
| | Defective AC (mains) cordset | Replace AC (mains) cordset |
| | Defective display PWA or ribbon cable | Replace display PWA or ribbon cable |
| | Defective power supply PWA | Replace power supply PWA |
| Free flow test Section 5.2.11 | Cassette not properly seated | Reseat cassette |
| | Defective cassette | Replace cassette |
| | Defective or dirty valve pins | Clean valve pins |
| | | Replace mechanism assembly |
| Proximal occlusion test Section 5.2.12 | Closed proximal clamp | Open clamp |
| | Cassette not properly primed | Reprime cassette |
| | Defective cassette | Replace cassette |
| | Dirty sensor pin | Clean sensor pin |
| | Defective sensor PWA | Replace mechanism assembly |
| Distal occlusion test Section 5.2.13 | Cassette not properly primed | Reprime cassette |
| | Defective cassette | Replace cassette |
| | Dirty sensor pin | Clean sensor pin |
| | Defective sensor PWA | Replace mechanism assembly |

Table 6-6. PVT Troubleshooting

| Test Failures | Possible Causes | Corrective Actions |
|---|--|--|
| Delivery accuracy test <i>Section 5.2.14</i> | Set not properly primed | Reprime set |
| | Damaged or faulty set | Prime using new set |
| | Defective mechanism assembly | Replace mechanism assembly |
| Empty container/ air-in-line alarm test <i>Section 5.2.15</i> | Defective special cassette | Replace special cassette |
| | Dirty bubble sensors | Clean bubble sensors |
| | Defective bubble sensor PWA | Replace mechanism assembly |
| | Defective sensor PWA | Replace mechanism assembly |
| Electrical safety test <i>Section 5.2.16</i> | Insufficient ground connection | Attach lead to T point screw on rear of infusion system |
| | Defective AC (mains) cordset | Replace AC (mains) cordset |
| | Defective power supply PWA | Replace power supply PWA |
| Battery charger current test (optional) <i>Section 5.4.1</i> | Blown fuse | Replace fuse |
| | Defective AC (mains) cordset | Replace AC (mains) cordset |
| | Defective power supply PWA | Replace power supply PWA |
| DataPort connection/ ground continuity test (optional) <i>Section 5.5</i> | Insufficient ground connection from DataPort connector to ground screw | Attach ground wire from DataPort connector to ground screw |
| | Defective DataPort/MCU cable assembly | Replace DataPort/MCU cable assembly |
| | DataPort/MCU cable not properly seated on MCU PWA | Reseat DataPort/MCU cable assembly to MCU PWA |

This page intentionally left blank.

Section 7

REPLACEABLE PARTS AND REPAIRS

This section itemizes all parts and subassemblies of the XL and XLM infusion systems that are repairable within the scope of this manual. In addition, this section details replacement procedures for all listed parts.

7.1

REPLACEABLE PARTS

Replaceable parts for the infusion system are itemized in the spare parts price list and are identified in *Figure 9-1, Illustrated Parts Breakdown. Table 9-2, IPB for the Infusion System*, identifies each infusion system part by an index number that correlates to *Figure 9-1*.

To request a copy of the current spare parts price list, [contact Hospira \(see Section 6.1, Technical Assistance\)](#), or to view the catalog online, visit the website at:

www.hospiraparts.com

For convenient reference, insert a copy of the spare parts price list here.

This page intentionally left blank.

7.2

REPLACEMENT PROCEDURES

This section contains safety and equipment precautions, required tools and materials, and step-by-step procedures for replacing parts in the infusion system. Unless otherwise stated, always perform the PVT after a replacement procedure.

7.2.1

SAFETY AND EQUIPMENT PRECAUTIONS

Before opening the front enclosure of the infusion system, take all necessary precautions for working on high-voltage equipment.

WARNING: POSSIBLE EXPLOSION HAZARD EXISTS IF THE INFUSION SYSTEM IS SERVICED OR REPAIRED IN THE PRESENCE OF FLAMMABLE ANESTHETICS.

WARNING: UNLESS OTHERWISE INDICATED, DISCONNECT THE INFUSION SYSTEM FROM AC POWER BEFORE PERFORMING ANY REPLACEMENT PROCEDURE.

CAUTION: Use proper ESD grounding techniques when handling components. Wear an antistatic wrist strap and use an ESD-protected workstation. Store PWAs in antistatic bags before placing them on any surface.

7.2.2

REQUIRED TOOLS AND MATERIALS

The following tools and materials, or equivalents, are required for the replacement procedures in this section. In addition, the beginning of each procedure lists tools and materials required for that specific procedure.

- Set of nutdrivers (1/4, 3/16, and 5/16 inch)
- Medium size flat blade screwdriver
- No. 2 Phillips® screwdriver
- Fuse puller
- Wide-head pliers
- Long needle nose pliers
- Diagonal cutters
- X-acto® knife (with square, round, and pointed blades)
- Wood chisel, 3/8 inch
- Mild solvent (such as isopropyl alcohol)

7.2.3

RUBBER FOOT PAD REPLACEMENT

Recommended tools and materials for this procedure are a 3/8 inch wood chisel or an X-acto knife and mild solvent.

The replacement part for this procedure is:

Foot Pad, Rubber

To replace the rubber foot pads, refer to [Figure 7-1, Bottom View of the Infusion System](#), then proceed as follows:

1. Turn the control knob to OFF/CHARGE.
2. Disconnect the infusion system from AC (mains) power.
3. Set the infusion system on its back to access the foot pads.
4. Using a 3/8 inch wood chisel or an X-acto knife, remove the rubber foot pad and scrape the enclosure recess to remove adhesive residue.

 **Note:** Each adhesive-backed rubber foot pad is bonded in its recess. Do not damage the recess.

5. Using a mild solvent, clean the enclosure recess.
6. Remove the protective backing from the self-adhesive surface on the replacement rubber foot pad and bond the foot pad in place.
7. After approximately five minutes, verify the foot pad is secure.
8. Connect the infusion system to AC (mains) power.

Replacement of a rubber foot pad is a routine maintenance procedure and no verification procedure is normally required. However, if the infusion system may have been damaged during this procedure, perform the PVT in [Section 5.2](#).

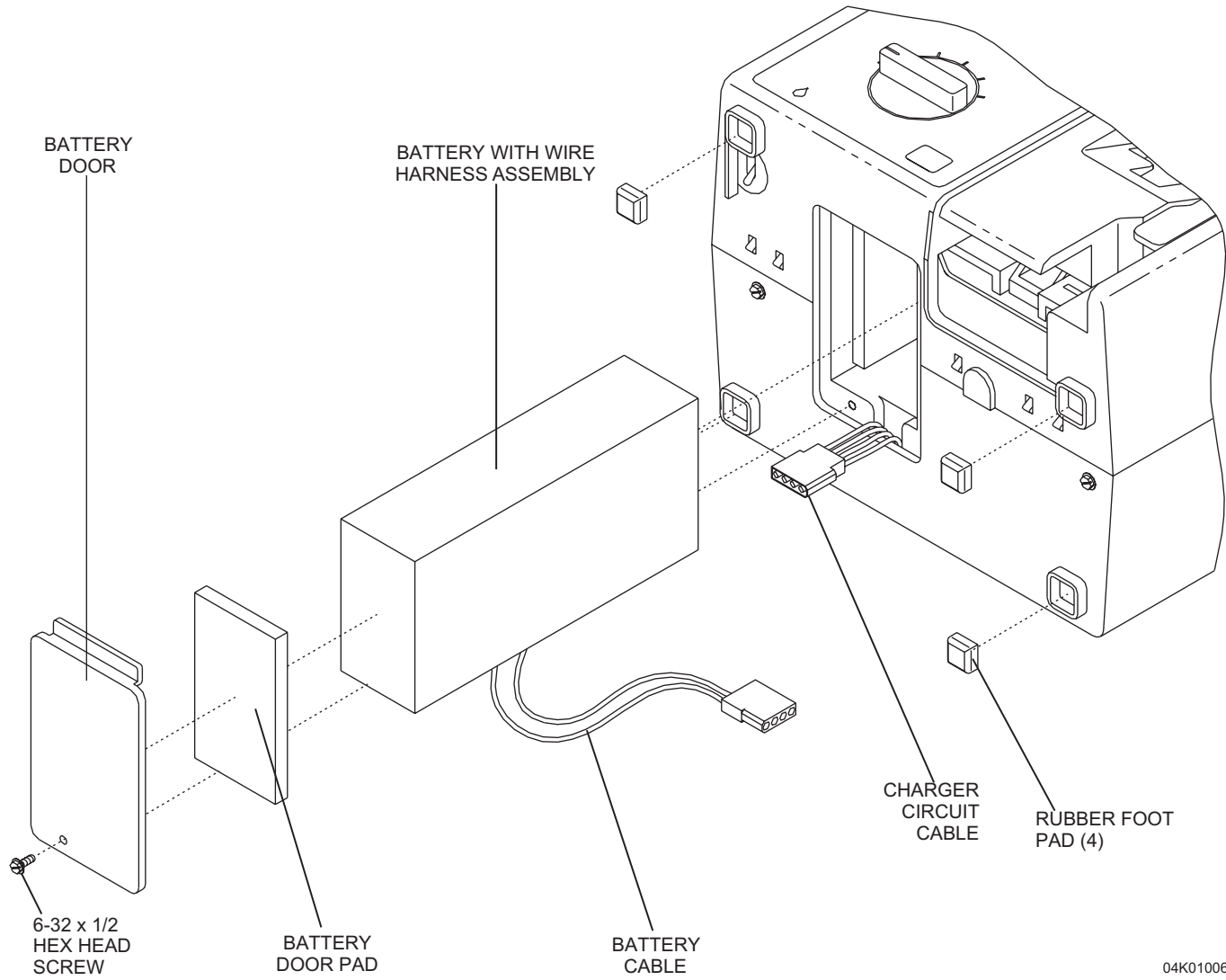

Figure 7-1. Bottom View of the Infusion System

7.2.4

BATTERY WITH WIRE HARNESS ASSEMBLY, BATTERY DOOR, AND BATTERY DOOR PAD REPLACEMENT

Recommended tools and materials for this procedure are a medium size flat blade screwdriver, an X-acto knife, and mild solvent.

The replacement parts for this procedure are:

**Screw, 6-32 x 1/2, Hex Head, Slotted
Assembly, Battery, with Wire Harness
Pad, Door, Battery
Door, Battery**

To replace the battery, battery door, and battery door pad, refer to [Figure 7-1](#), then proceed as follows:

1. Turn the control knob to OFF/CHARGE.
2. Disconnect the infusion system from AC (mains) power.
3. Set the infusion system on its back to access the bottom.
4. Using a medium size flat blade screwdriver, remove the hex head screw securing the battery door to the infusion system. Remove the battery door and replace it if necessary.
5. Inspect the battery door pad for damage. If the pad is damaged, remove it using an X-acto knife and mild solvent. Dry the battery door thoroughly, and install a new battery door pad on the battery door.
6. Disconnect the battery cable from the charger circuit cable. Pull the battery cable wires and connector outside the enclosure. Remove the battery.
7. Connect the replacement battery cable to the charger circuit cable.

 **Note:** The cable connectors are keyed so that cables cannot be connected incorrectly.

8. Insert the replacement battery into the enclosure, confirming that the battery cable is not pinched between the battery and the enclosure.
9. Using a medium size flat blade screwdriver, replace and tighten the hex head screw to secure the battery door to the infusion system.
10. Connect the infusion system to AC (mains) power.

To verify successful battery, battery door, and battery door pad replacement, perform the PVT in [Section 5.2](#).

7.2.5

SEPARATING THE FRONT ENCLOSURE ASSEMBLY, REAR ENCLOSURE ASSEMBLY, AND MAIN CHASSIS ASSEMBLY

The recommended tool for this procedure is a medium size flat blade screwdriver.

CAUTION: Use proper ESD grounding techniques when handling components. Wear an antistatic wrist strap and use an ESD-protected workstation. Store the PWA in an antistatic bag before placing it on any surface.

To separate the front enclosure assembly, rear enclosure assembly, and main chassis assembly, refer to [Figure 7-2, Front Enclosure, Main Chassis Assembly, and Rear Enclosure](#), then proceed as follows:

1. Turn the control knob to OFF/CHARGE.
2. Disconnect the infusion system from AC (mains) power.
3. Remove the battery door and battery as described in [Section 7.2.4](#).
4. Using the medium size flat blade screwdriver, remove the two remaining hex head screws located on the enclosure bottom. Remove the two hex head screws from the carrying handle.

 **Note:** Do not remove the ground test-point screw.

5. Separate the front and rear enclosures by carefully pulling the carrying handles apart.
6. Disconnect the MCU/Display PWA cable from J3 on the MCU PWA ([see Figure 7-2](#)).
7. (XLM only) Slowly back off the rear enclosure assembly two to three inches and disconnect the MCU/Buzzer cable from J10 on the MCU PWA.
8. (For devices equipped with DataPort only) Disconnect the DataPort/MCU cable from J11 on the MCU PWA.
9. Separate the main chassis assembly from the rear enclosure assembly, being careful not to remove the power supply PWA from the rear enclosure.

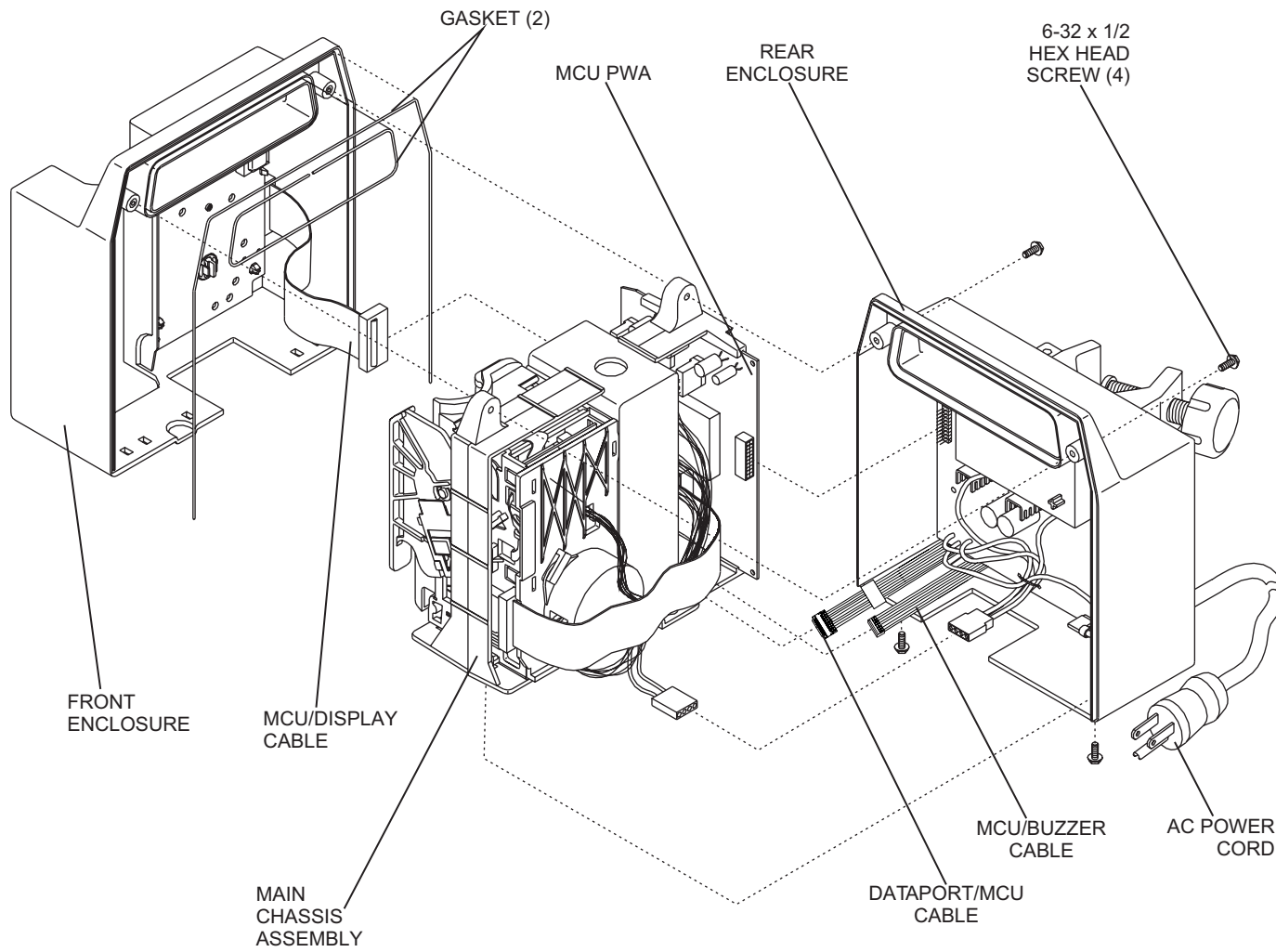

04K01005

Figure 7-2. Front Enclosure, Main Chassis Assembly, and Rear Enclosure

7.2.6**FRONT ENCLOSURE ASSEMBLY, REAR ENCLOSURE ASSEMBLY, OR MAIN CHASSIS ASSEMBLY REPLACEMENT**

The recommended tool for this procedure is a medium size flat blade screwdriver.

The replacement parts for this procedure are:

Assembly, Enclosure, Front
Assembly, Enclosure, Rear
Chassis, Main
Gasket, Front/Rear Enclosure

CAUTION: Use proper ESD grounding techniques when handling components. Wear an antistatic wrist strap and use an ESD-protected workstation. Store the PWA in an antistatic bag before placing it on any surface.

To replace the front enclosure assembly, rear enclosure assembly, or main chassis assembly, refer to [Figure 7-2](#), then proceed as follows:

1. Separate the front enclosure assembly, rear enclosure assembly, and main chassis assembly as described in [Section 7.2.5](#).
2. To replace the front enclosure assembly, remove the specific components described in [Section 7.2.7, Front Enclosure Assembly Component Replacement](#).
3. To replace the rear enclosure assembly, remove the specific components described in [Section 7.2.8, Rear Enclosure Assembly Component Replacement](#).
4. To replace the main chassis assembly, remove the specific components described in [Section 7.2.9, Main Chassis Assembly Component Replacement](#).
5. Inspect the front enclosure assembly gaskets and replace if necessary ([see Figure 7-2](#)).
6. Reassemble the replacement front enclosure assembly, rear enclosure assembly, or main chassis assembly components. Refer to the specific procedure in [Section 7.2.7, Section 7.2.8, or Section 7.2.9](#).
7. Reassemble the device in the exact reverse order of separation.

 **Note:** (XLM with DataPort) When joining the front and rear enclosures, do not pinch the DataPort/MCU cable between the two enclosures ([see Figure 7-12, DataPort Assembly \(Domestic\)](#) or [Figure 7-13, DataPort Assembly \(International\)](#)).

8. Connect the infusion system to AC (mains) power.

To verify successful front enclosure, rear enclosure, or main chassis replacement, perform the PVT in [Section 5.2](#).

7.2.7**FRONT ENCLOSURE ASSEMBLY COMPONENT REPLACEMENT**

Front enclosure assembly component replacement includes the replacement of the following:

- ❑ Display PWA and MCU/display cable
- ❑ Switch-activated front panel keys
- ❑ Control knob, knob detent, washer, and snap retainer
- ❑ Front panel label

To replace the front enclosure assembly components, refer to either [Figure 7-3, Display PWA and MCU/Display Cable](#), or [Figure 7-4, Front Enclosure Assembly Components](#), then proceed as detailed in the following sections.

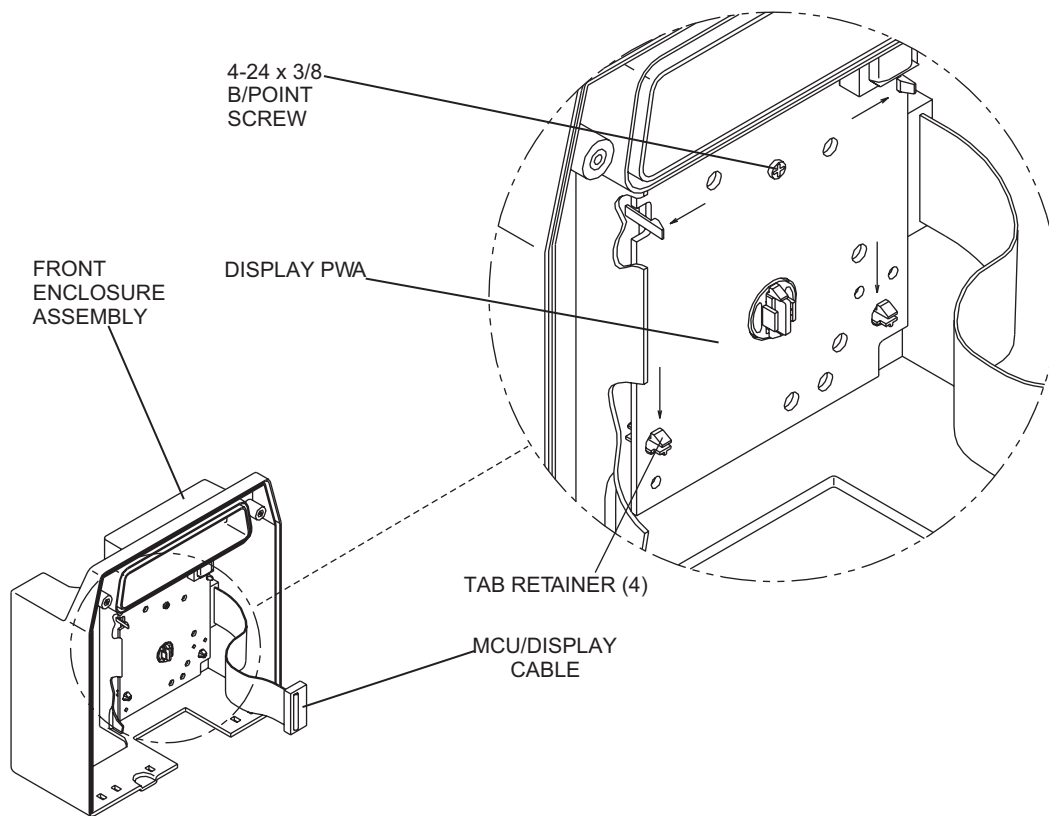

04K01007

Figure 7-3. Display PWA and MCU/Display Cable

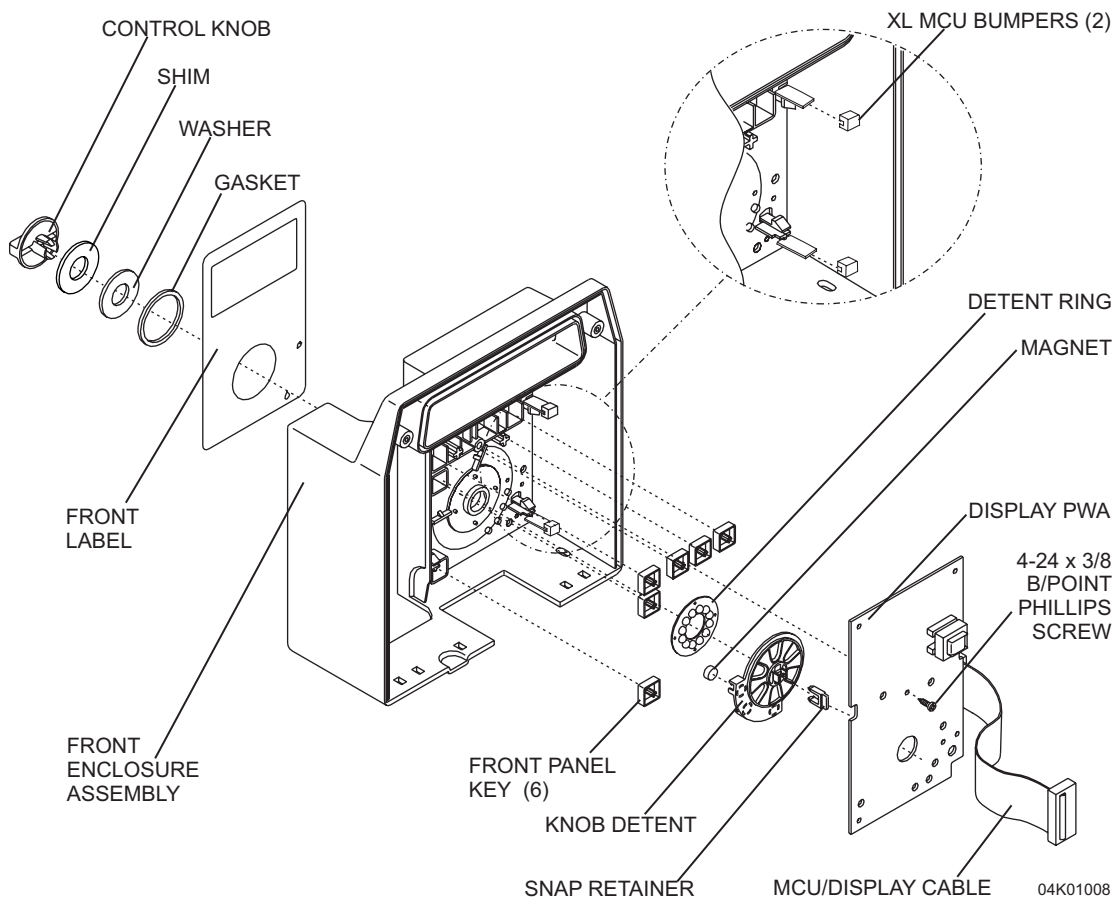

Figure 7-4. Front Enclosure Assembly Components

7.2.7.1

DISPLAY PWA AND MCU/DISPLAY CABLE REPLACEMENT

Recommended tools for this procedure are a medium size flat blade screwdriver and a No. 2 Phillips screwdriver.

The replacement parts for this procedure are:

**PWA, Display
Assembly, Cable, MCU/Display
Bumper, XL MCU
Screw, 4-24 x 3/8, B/Point, Phillips**

CAUTION: Use proper ESD grounding techniques when handling components. Wear an antistatic wrist strap and use an ESD-protected workstation. Store the PWA in an antistatic bag before placing it on any surface.

To replace the display PWA and the MCU/display cable, refer to [Figure 7-3](#) and [Figure 7-4](#), then proceed as follows:

1. Separate the front enclosure assembly and rear enclosure assembly as described in [Section 7.2.5](#).

2. Place the front enclosure assembly face down.
3. Remove and replace the two XL MCU Bumpers.
4. Using a No. 2 Phillips screwdriver, remove the Phillips screw securing the display PWA to the control knob assembly.
5. Disengage the four tab retainers securing the display PWA to the front enclosure assembly. Remove the display PWA from the front enclosure assembly.
6. Disconnect the MCU/display cable from the display PWA. Replace the MCU/display cable if it is defective or damaged.
7. Install the replacement display PWA in the exact reverse order of removal.
8. Reassemble the device in the exact reverse order of disassembly.

 **Note:** (XLM with DataPort) When joining the front and rear enclosures, do not pinch the DataPort/MCU cable between the two enclosures.

9. Connect the infusion system to AC (mains) power.

To verify successful display PWA and MCU/display cable replacement, perform the PVT in [Section 5.2](#).

7.2.7.2

FRONT PANEL KEY REPLACEMENT

Recommended tools for this procedure are a medium size flat blade screwdriver and No. 2 Phillips screwdriver.

The replacement part for this procedure is:

Key, Front Panel, Switch Activated

CAUTION: Use proper ESD grounding techniques when handling components. Wear an antistatic wrist strap and use an ESD-protected workstation. Store the PWA in an antistatic bag before placing it on any surface.

To replace the front panel keys, refer to [Figure 7-4](#), then proceed as follows:

1. Separate the front enclosure assembly and rear enclosure assembly as described in [Section 7.2.5](#).
2. Remove the display PWA as described in [Section 7.2.7.1](#).
3. Remove the front panel keys from the key recesses and install replacements ([see Figure 7-4](#)).
4. Reassemble the device in the exact reverse order of disassembly.

 **Note:** (XLM with DataPort) When joining the front and rear enclosures, do not pinch the DataPort/MCU cable between the two enclosures.

5. Connect the infusion system to AC (mains) power.

To verify successful front panel key replacement, perform the PVT in [Section 5.2](#).

7.2.7.3**CONTROL KNOB, KNOB DETENT, WASHER, GASKET, SNAP RETAINER, AND DETENT RING REPLACEMENT**

Recommended tools for this procedure are a small flat blade screwdriver, a medium size flat blade screwdriver, a No. 2 Phillips screwdriver, and long needle nose pliers.

The replacement parts for this procedure are:

Retainer, Snap, Knob
Knob, Control
Detent, Knob
Washer, Knob
Gasket, Knob
Ring, Detent
Shim
Magnet

CAUTION: Use proper ESD grounding techniques when handling components. Wear an antistatic wrist strap and use an ESD-protected workstation. Store the PWA in an antistatic bag before placing it on any surface.

To replace the control knob, knob detent, washer, gasket, detent ring, and snap retainer, refer to *Figure 7-4*, then proceed as follows:

1. Separate the front enclosure assembly and rear enclosure assembly as described in *Section 7.2.5*.
2. Remove the display PWA as described in *Section 7.2.7.1*.
3. Remove the front panel keys as described in *Section 7.2.7.2*.
4. Using long needle nose pliers, carefully remove the snap retainer.
5. Remove the control knob, knob detent, shim, washer, gasket, and detent ring.
6. Inspect the magnet on the knob detent. If the magnet appears damaged, carefully remove it using the small flat blade screwdriver. Install the replacement, assuring that the dot on the magnet is facing up.
7. Install the replacement control knob, washer, and gasket.
 - Fit the gasket into the circular recess on the front side of the front enclosure.
 - Install the washer on the control knob.
 - Install the shim on the control knob.
 - Place the control knob through the hole in the front enclosure.
 - Turn the control knob to OFF/CHARGE.
8. Place the front enclosure assembly face down. Place the detent ring on the four pins, centered on the control knob. Assure that the raised bumps on the detent ring are facing up.
9. Using the snap retainer, secure the knob detent on the control knob retainer clips and splines. Press the snap retainer firmly until it is secure.

 **Note:** When the control knob is at OFF/CHARGE, the knob detent is positioned on the detent ring as shown in *Figure 7-4*.

10. Verify that the control knob rotates fully.
11. Reassemble the device in the exact reverse order of disassembly.

-  **Note:** (XLM with DataPort) When joining the front and rear enclosures, do not pinch the DataPort/MCU cable between the two enclosures.

12. Connect the infusion system to AC (mains) power.

To verify successful control knob, knob detent, washer, and snap retainer replacement, perform the PVT in [Section 5.2](#).

7.2.7.4

FRONT PANEL LABEL REPLACEMENT

Recommended tools and materials for this procedure are an X-acto knife, long needle nose pliers, and mild solvent.

The replacement part for this procedure is:

Label, Front Panel

To replace the front panel label, refer to [Figure 7-4](#), then proceed as follows:

1. Turn the control knob to OFF/CHARGE.
2. Disconnect the infusion system from AC (mains) power.
3. Using an X-acto knife, remove the front panel label from the front panel enclosure.
4. Using a mild solvent, remove adhesive residue from the front panel assembly recess.
5. Remove the adhesive backing from the replacement front panel label and press the label into place on the front enclosure assembly.

Replacement of the front panel label is a routine maintenance procedure and no verification procedure is normally required. However, if the infusion system may have been damaged during this procedure, perform the PVT in [Section 5.2](#).

7.2.8

REAR ENCLOSURE ASSEMBLY COMPONENT REPLACEMENT

Rear enclosure assembly component replacement includes the replacement of the following:

- Fuses
- Power supply PWA
- Velcro retainer strap
- AC (mains) power cord, and strain relief bushing
- AC (mains) power cord (International)
- AC receptacle, EMI shield, and equipotential post
- LifeCare AC receptacle, bracket, gasket, seal, and equipotential post
- DataPort/MCU cable assembly
- LifeCare DataPort/MCU cable assembly
- Pole clamp extrusion, knob, backing plate, and adhesive-backed insulator
- Pole clamp shaft/knob assembly and the pole clamp shaft tip
- Buzzer PWA and MCU/buzzer cable

To replace the rear enclosure assembly components, proceed as detailed in the following sections.

7.2.8.1

FUSE REPLACEMENT

Recommended tools for this procedure are a medium size flat blade screwdriver and a fuse puller.

The replacement part for this procedure is:

Fuse, 0.5A, 250V, Slo-Blo, 5 x 20 mm
Cover, Fuse 5 x 20 mm

To replace the fuse, refer to [Figure 7-5, Fuse Replacement \(115 VAC\)](#) or [Figure 7-6, Fuse Replacement \(220 VAC\)](#), then proceed as follows:

1. Separate the front enclosure assembly and rear enclosure assembly as described in [Section 7.2.5](#).
2. Remove the two plastic fuse covers. Using the fuse puller, remove the two fuses on the power supply PWA and install replacements.

CAUTION: Confirm replacement fuse rating is identical to fuse rating indicated on the power supply PWA or equipment damage may occur.

3. Reassemble the device in the exact reverse order of disassembly.

 **Note:** (XLM with DataPort) When joining the front and rear enclosures, do not pinch the DataPort/MCU cable between the two enclosures.

4. Connect the infusion system to AC (mains) power.

To verify successful fuse replacement, perform the PVT in [Section 5.2](#).

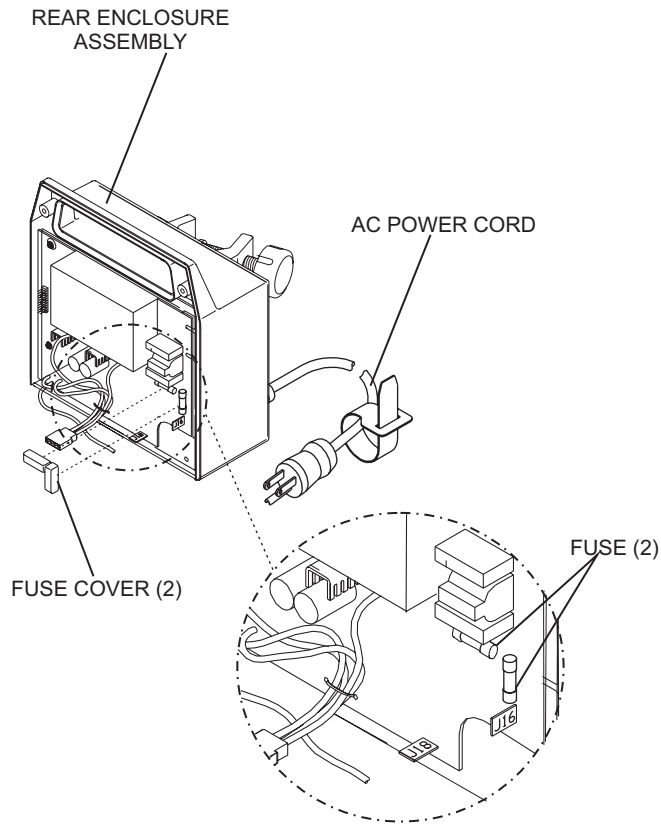

04K01034

Figure 7-5. Fuse Replacement (115 VAC)

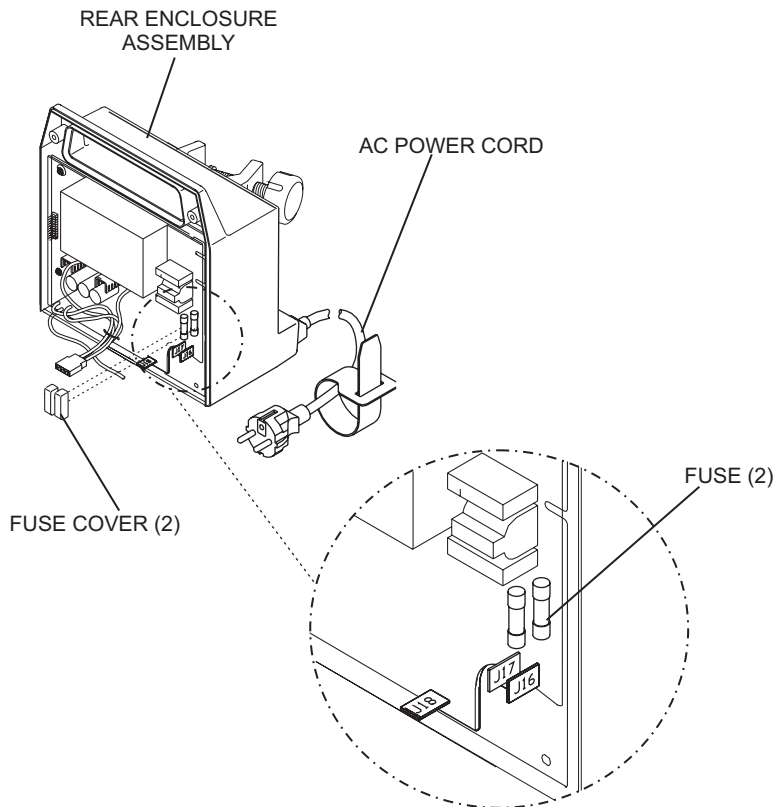

04K01035

Figure 7-6. Fuse Replacement (220 VAC)

7.2.8.2

POWER SUPPLY PWA REPLACEMENT

Recommended tools for this procedure are a medium size flat blade screwdriver and a 1/4 inch nutdriver.

The replacement parts for this procedure are:

**PWA, Power Supply
Screw, 6-32 x 5/16, Hex Head, Slotted**

CAUTION: Use proper ESD grounding techniques when handling components. Wear an antistatic wrist strap and use an ESD-protected workstation. Store the PWA in an antistatic bag before placing it on any surface.

To replace the power supply PWA, refer to *Figure 7-7, Power Supply PWA*, then proceed as follows:

1. Separate the front enclosure assembly and rear enclosure assembly as described in *Section 7.2.5*.
2. Disconnect the AC (mains) power cord wire from J16 (*see Table 7-1, Wire Color Coding*).
3. Disconnect the AC (mains) power cord wire from J17 (*see Table 7-1*).
4. For all infusion systems except Plum XL domestic: disconnect the AC (mains) power cord wire from J18 (*see Table 7-1*).
5. Using a 1/4 inch nutdriver, remove the two hex head screws securing the power supply PWA to the rear enclosure assembly. Remove the power supply PWA from the rear enclosure assembly.
6. Install the replacement power supply PWA.
7. Connect the AC (mains) power cord wire to J17 (*see Table 7-1*).
8. Connect the AC (mains) power cord wire to J16 (*see Table 7-1*).
9. For all infusion systems except Plum XL domestic: connect the AC (mains) power cord wire to J18 (*see Table 7-1*).
10. Reassemble the device in the exact reverse order of disassembly.
 -  **Note:** (XLM with DataPort) When joining the front and rear enclosures, do not pinch the DataPort/MCU cable between the two enclosures.
11. Connect the infusion system to AC (mains) power.

To verify successful power supply PWA replacement, perform the PVT in *Section 5.2*.

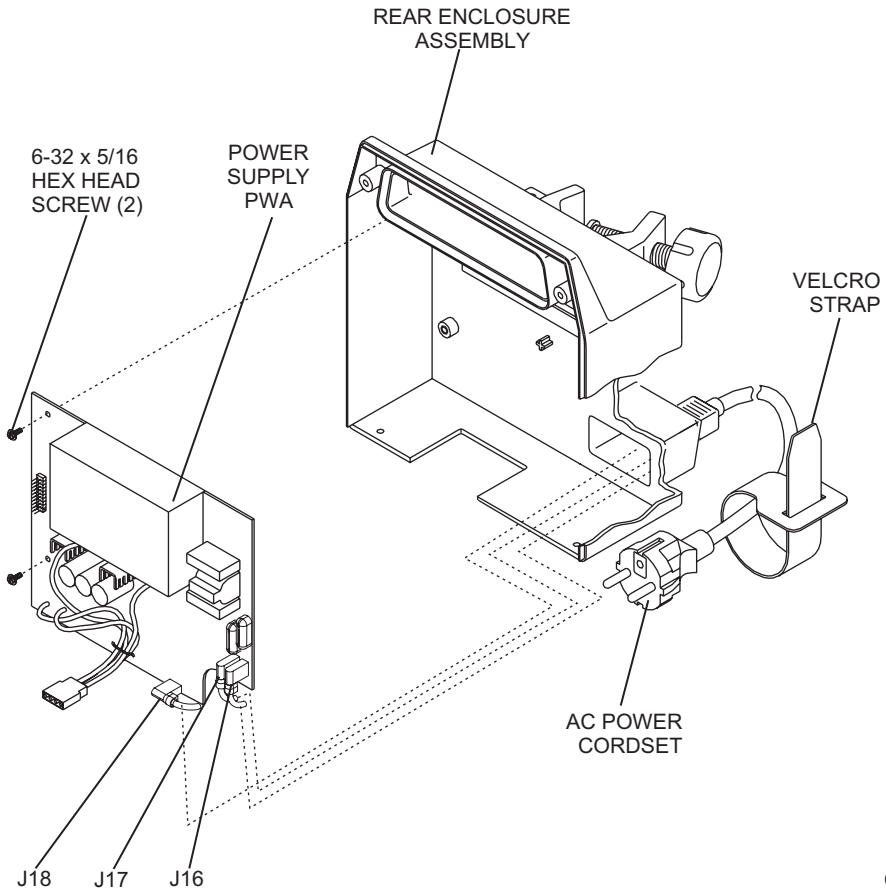



Figure 7-7. Power Supply PWA

| Table 7-1. Wire Color Coding | | | |
|---|-------------------|---------------|--------------------|
| Voltage | Wire Color | Signal | Connects To |
|  115V | Black | Hot (line) | J16 |
| | White | Neutral | J17 |
| | Green | Ground | Rear panel |
|  220V | Brown | Hot (line) | J16 |
| | Blue | Neutral | J17 |
| | Yellow/green | Earth | J18 |

7.2.8.3

VELCRO RETAINER STRAP REPLACEMENT

No tools are required for this procedure.

The replacement part for this procedure is:

Strap, Velcro, 1.75 in x 10 in, Black

To replace the Velcro retainer strap, remove the strap from the power cord and install the replacement (see [Figure 7-7](#)).

Replacement of the Velcro retainer strap is a routine maintenance procedure and no verification procedure is normally required. However, if the infusion system may have been damaged during the Velcro retainer strap replacement, perform the PVT in [Section 5.2](#).

7.2.8.4

AC (MAINS) POWER CORD AND STRAIN RELIEF BUSHING REPLACEMENT

Recommended tools for this procedure are a medium size flat blade screwdriver, a 1/4 inch nutdriver, and pliers.

The replacement parts for this procedure are:

Cordset, AC Power, Hospital Grade
Strain Relief, Nylon, Black
Nut, 6-32, KEP, with Washer
Washer, Flat, #6
Screw, 6-32 x 3/4, Hex Head, Slotted, w/Washer (XL)
Screw, 6-32 x 1, Hex Head, Slotted, w/Washer (XLM)

CAUTION: Use proper ESD grounding techniques when handling components. Wear an antistatic wrist strap and use an ESD-protected workstation. Store the PWA in an antistatic bag before placing it on any surface.

To replace the AC (mains) power cord, and strain relief bushing, refer to [Figure 7-8, AC Power Cord \(115 VAC - Plum XL\)](#) or [Figure 7-9, AC Power Cord \(115 VAC - Plum XLM\)](#), then proceed as follows:

1. Separate the front enclosure assembly and rear enclosure assembly as described in [Section 7.2.5](#).
2. Using a 1/4 inch nutdriver, remove the two hex head nuts from the hex head ground screw.
3. Disconnect the green ground wire from the ground screw.
4. Disconnect the AC (mains) power cord wire from J16 (see [Table 7-1, Wire Color Coding](#)).
5. Disconnect the AC (mains) power cord wire from J17 (see [Table 7-1](#)).
6. Use the pliers to remove the strain relief bushing.
7. Pull the AC (mains) power cord through the mounting hole in the rear enclosure assembly.
8. Install the replacement AC (mains) power cord in the exact reverse order of removal.

9. Connect the AC (mains) power cord wire to J17 (*see Table 7-1*).
10. Connect the AC (mains) power cord wire to J16 (*see Table 7-1*).
11. Connect the ground wire with the grounding lug to the ground screw. Using a 1/4 inch nutdriver, replace and tighten the two hex head nuts to the ground screw.
12. Reassemble the device in the exact reverse order of disassembly.

Note: (XLM with DataPort) When joining the front and rear enclosures, do not pinch the DataPort/MCU cable between the two enclosures.

13. Connect the infusion system to AC (mains) power.

To verify successful AC (mains) power cord, strain relief bushing, and Velcro strap replacement, perform the PVT in [Section 5.2](#).

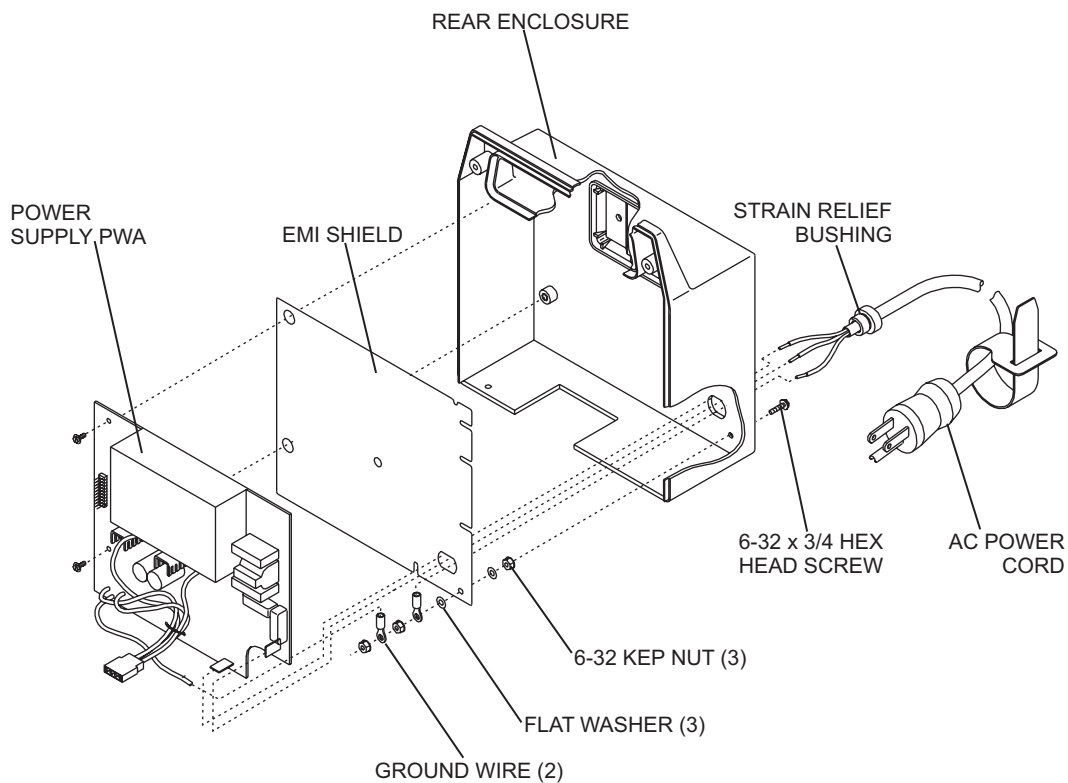

04K01044

Figure 7-8. AC Power Cord (115 VAC - Plum XL)

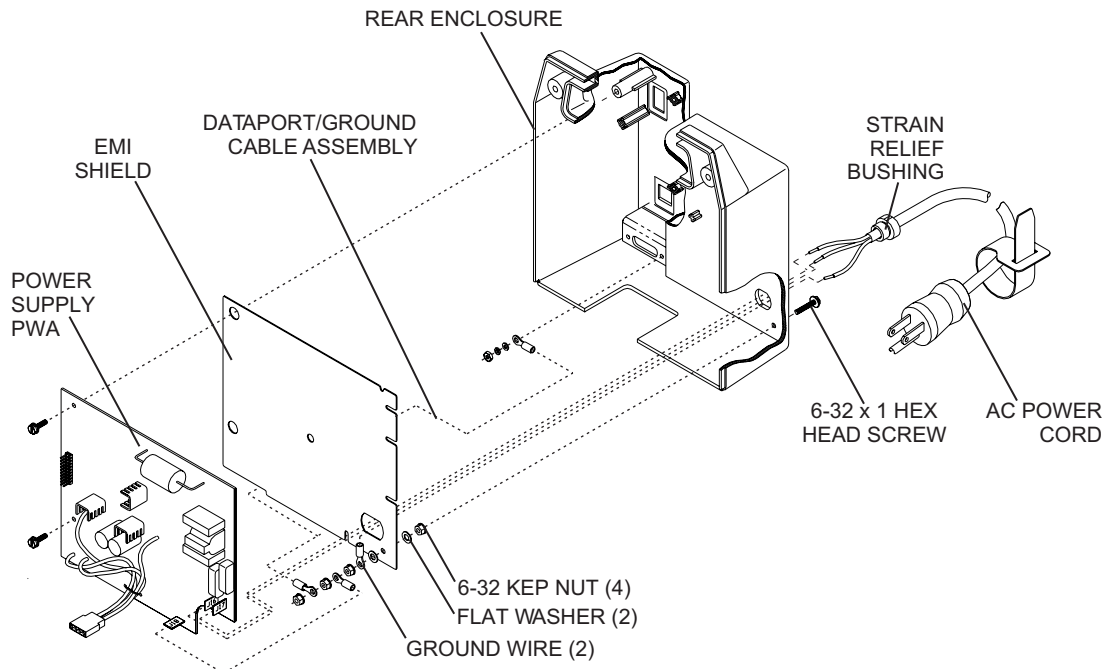

04K01045

Figure 7-9. AC Power Cord (115 VAC - Plum XLM)

7.2.8.5

AC (MAINS) POWER CORD REPLACEMENT (INTERNATIONAL)



No tools are required for this procedure.

The replacement part for this procedure is:

Cordset, AC Power, Hospital, International

To replace the AC (mains) power cord, refer to [Figure 7-10, AC Power Cord \(220 VAC - Plum XLM\)](#) or [Figure 7-11, AC Power Cord \(220 VAC - Plum XLM\)](#), then disconnect the power cord from the rear of the infusion system and connect the replacement power cord.

Replacement of the AC (mains) power cord is a routine maintenance procedure and no verification procedure is normally required. However, if the infusion system may have been damaged during this procedure, perform the PVT in [Section 5.2](#).

7.2.8.6

AC RECEPTACLE, EMI SHIELD, AND EQUIPOTENTIAL POST REPLACEMENT

Recommended tool for this procedure is a 6 mm nutdriver.

The replacement parts for this procedure are:

Receptacle, AC Connection
Post, Equipotential
Shield, EMI
Nut, Hex, 6mm
Washer, Lock
Washer, Flat
Washer, Flat, 1/4 inch

CAUTION: Use proper ESD grounding techniques when handling components. Wear an antistatic wrist strap and use an ESD-protected workstation. Store the PWA in an antistatic bag before placing it on any surface.

To replace the AC connection receptacle and equipotential post, refer to [Figure 7-10](#), then proceed as follows:

1. Separate the front enclosure assembly and rear enclosure assembly as described in [Section 7.2.5](#).
2. Remove the power supply PWA as described in [Section 7.2.8.2](#).
3. Remove the hex nut and two washers holding the EMI shield to the equipotential post. Replace the EMI shield if necessary.
4. Remove the hex nut, three washers and three ground wires, then the remaining hex nut and washers from the equipotential post ([see Figure 7-10](#)).
5. Remove the equipotential post and replace if necessary.
6. Remove the AC receptacle by pulling it through the rear enclosure. Install a replacement if necessary.
7. Reassemble the device in the exact reverse order of disassembly.

 **Note:** (XLM with DataPort) When joining the front and rear enclosures, do not pinch the DataPort/MCU cable between the two enclosures.

8. Connect the infusion system to AC (mains) power.

To verify successful AC receptacle, EMI shield, and equipotential post replacement, perform the PVT in [Section 5.2](#).

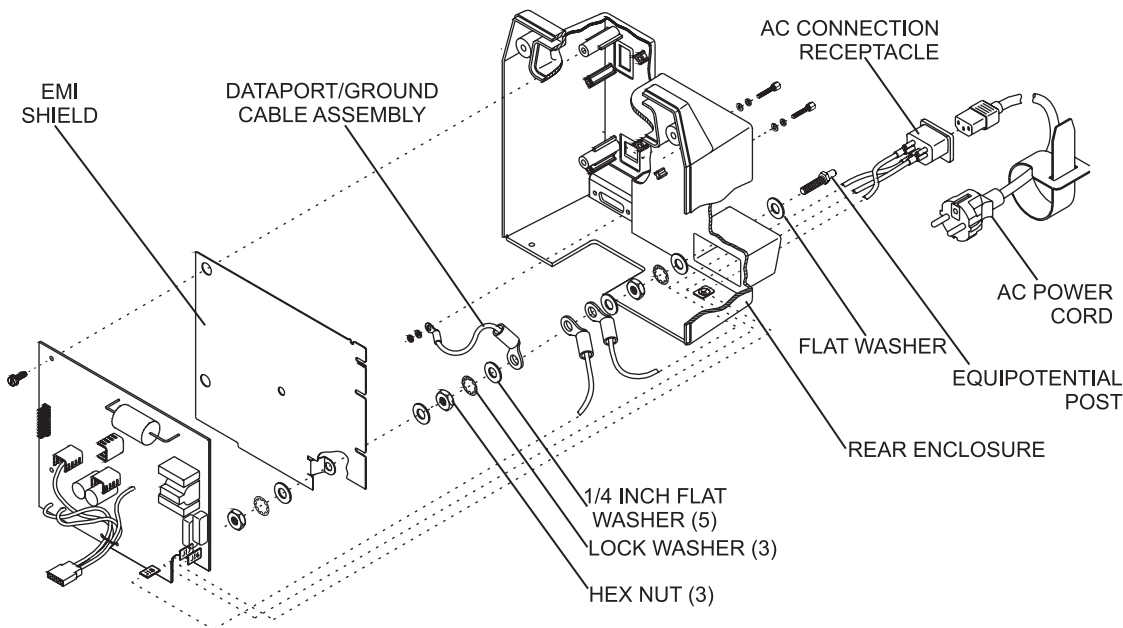

04K01042

Figure 7-10. AC Power Cord (220 VAC - Plum XLM)

7.2.8.7

LIFECARE AC RECEPTACLE, BRACKET, GASKET, SEAL, AND EQUIPOTENTIAL POST REPLACEMENT



Recommended tools for this procedure are a 10mm wrench, a 10mm nutdriver, a 1/4 inch nutdriver, and a 3/16 inch nutdriver.

The replacement parts for this procedure are:

Receptacle, AC
Gasket, AC Receptacle
Seal, Housing, AC Receptacle
Bracket, AC Receptacle
Assembly, Cable, DataPort/Ground
Post, Equipotential
Shield, EMI
Nut, Hex, Metric, DIN 439
Screw, Lock, 4-40

CAUTION: Use proper ESD grounding techniques when handling components. Wear an antistatic wrist strap and use an ESD-protected workstation. Store the PWA in an antistatic bag before placing it on any surface.

To replace the AC receptacle, refer to [Figure 7-11, AC Power Cord \(220 VAC - Plum XLM\)](#), and proceed as follows:

1. Separate the front enclosure assembly and rear enclosure assembly as described in [Section 7.2.5](#).
2. Remove the power supply PWA as described in [Section 7.2.8.2](#).
3. Carefully lift the EMI shield.
4. Using the 10mm nutdriver, remove the two nuts from the equipotential post.
5. Remove the DataPort/ground cable from the equipotential post. If the ground cable is damaged, use the 1/4 nutdriver to disconnect the other end by removing the 4-40 self locking nut from the DataPort bracket. Replace the ground cable.
6. Remove the EMI shield and replace if necessary.
7. Using the 3/16 nutdriver, remove the two 4-40 lock screws securing the AC receptacle to the rear enclosure.
8. Using the 10mm wrench, remove the equipotential post. Remove the AC receptacle bracket. Inspect both for damage, and replace if necessary.
9. Remove the AC receptacle housing seal, inspect for damage and replace if necessary.
10. Remove the AC receptacle gasket, inspect for damage and replace if necessary.
11. Remove the AC receptacle by pulling it away from the rear enclosure.
12. Install the replacement AC receptacle.
13. Reassemble the device in the exact reverse order of disassembly.

 **Note:** (XLM with DataPort) When joining the front and rear enclosures, do not pinch the DataPort/MCU cable between the two enclosures.

14. Connect the infusion system to AC (mains) power.

To verify successful AC receptacle, bracket, gasket, seal and equipotential post replacement, perform the PVT in [Section 5.2](#).

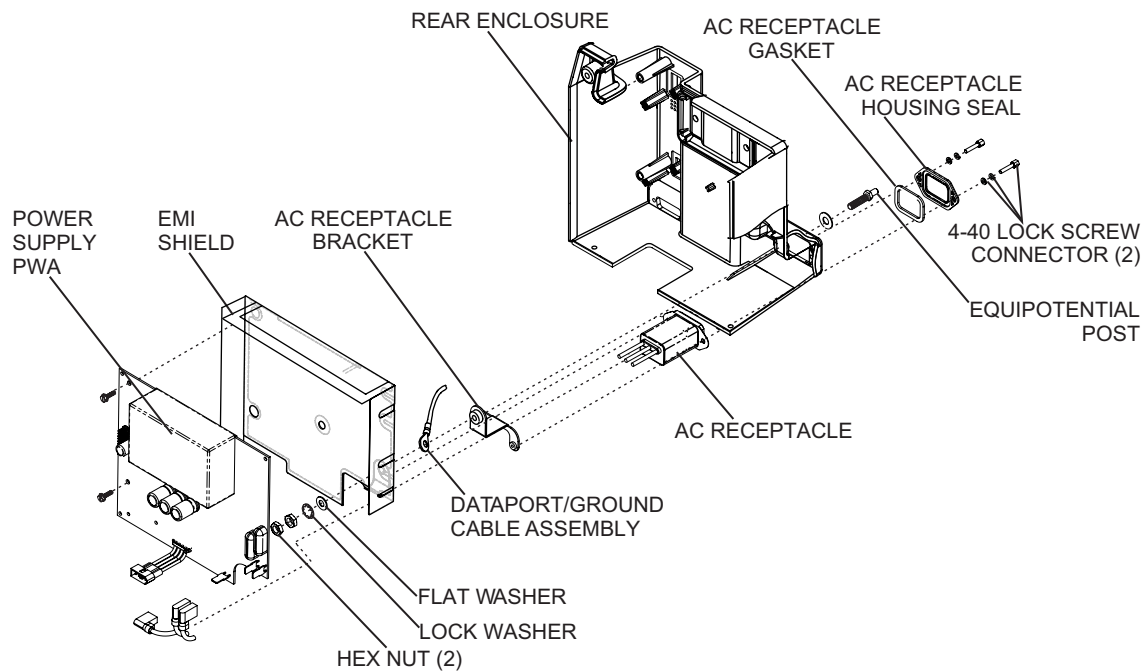

04K01043

Figure 7-11. AC Power Cord (220 VAC - Plum XLM)



7.2.8.8

DATAPORT/MCU CABLE ASSEMBLY REPLACEMENT (XLM WITH DATAPORT)

Recommended tools for this procedure are a medium size flat blade screwdriver, a 1/4 inch nutdriver, and a 3/16 inch nutdriver.

The replacement parts for this procedure are:

EMI Shield
Kit, Lock Screw Connector, 4-40
Kit, Lock Screw, 4-40 x 5/16
Assembly, Cable, DataPort/MCU
Assembly, Cable, DataPort/Ground

CAUTION: Use proper ESD grounding techniques when handling components. Wear an antistatic wrist strap and use an ESD-protected workstation. Store the PWA in an antistatic bag before placing it on any surface.

 **Note:** Do not connect DataPort when infusing.

To replace the DataPort/MCU cable assembly, refer to [Figure 7-12, DataPort Assembly \(Domestic\)](#), and proceed as follows:

1. Separate the front enclosure assembly and rear enclosure assembly as described in [Section 7.2.5](#).
2. Remove the power supply PWA as described in [Section 7.2.8.2](#).
3. Remove the EMI shield.
4. Using the 3/16 inch nutdriver, remove the DataPort ground cable nut from inside the rear case.
5. Remove the two lock screws on the outside of the rear case, disconnecting the DataPort ground cable.
6. Remove the DataPort/MCU cable assembly through the rear case, and install the replacement.
7. Replace the EMI shield.
8. Reassemble the device in the exact reverse order of disassembly.

 **Note:** (XLM with DataPort) When joining the front and rear enclosures, do not pinch the DataPort/MCU cable between the two enclosures.

9. Connect the infusion system to AC (mains) power.

To verify proper DataPort/MCU cable assembly replacement, perform the PVT in [Section 5.2](#) and the DataPort connection and ground continuity test in [Section 5.5](#).

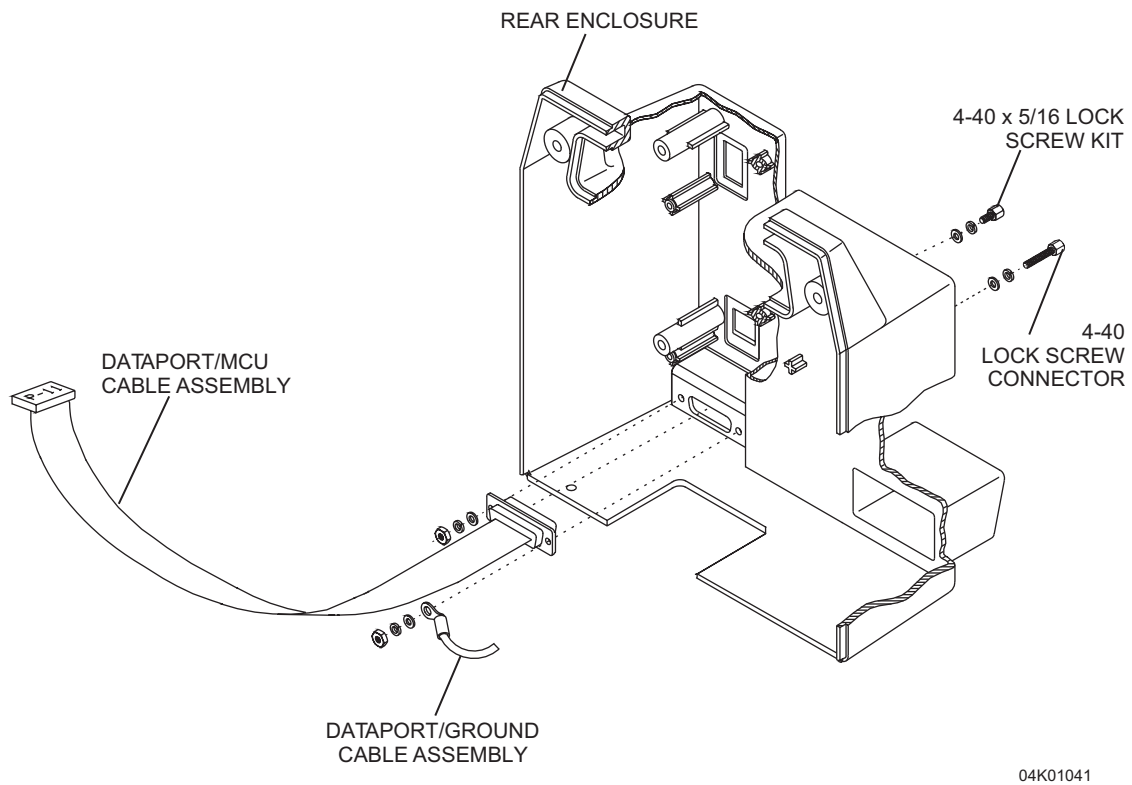



Figure 7-12. DataPort Assembly (Domestic)

7.2.8.9

LIFECARE DATAPORT/MCU CABLE ASSEMBLY REPLACEMENT (XLM WITH DATAPORT)

 Recommended tools for this procedure are a medium size flat blade screwdriver, 1/4 inch nutdriver, 3/16 inch nutdriver, and 5/16 inch nutdriver.

The replacement parts for this procedure are:

Kit, Screw, Lock, 4-40
Assembly, Cable, DataPort/MCU
Gasket, DataPort
Bracket, DataPort
Cap, DataPort
Washer, Shoulder, #4
Screw, 4-40 x 1/4, Hex Head

CAUTION: Use proper ESD grounding techniques when handling components. Wear an antistatic wrist strap and use an ESD-protected workstation. Store the PWA in an antistatic bag before placing it on any surface.

 **Note:** Do not connect DataPort when infusing.

To replace the DataPort/MCU cable assembly, refer to [Figure 7-13, DataPort Assembly \(International\)](#), and proceed as follows:

1. Separate the front enclosure assembly and rear enclosure assembly as described in [Section 7.2.5](#).
2. Remove the power supply PWA as described in [Section 7.2.8.2](#).
3. Using the 1/4 nutdriver, remove the two hex head screws and two shoulder washers securing the DataPort cap. Remove the DataPort cap. Inspect all items for damage and replace if necessary.
4. Using the 3/16 nutdriver, remove the two 4-40 connector screws and washers on the outside of the rear enclosure. Use the 1/4 nutdriver to keep the two 4-40 self locking nuts on the inside of the rear enclosure from turning.
5. Disconnect the DataPort/ground cable.
6. Remove the DataPort bracket, inspect the bracket for damage and replace it if necessary.
7. Remove the DataPort gasket, inspect the gasket for damage and replace it if necessary.
8. Remove the DataPort/MCU cable assembly by pulling it through the rear enclosure. Inspect for damage and replace it if necessary.
9. Re-install the power supply PWA in the exact reverse order of removal.
10. Join the front enclosure assembly and rear enclosure assembly in the exact reverse order of separation.

 **Note:** (XLM with DataPort) When joining the front and rear enclosures, do not pinch the DataPort/MCU cable between the two enclosures.

11. Connect the infusion system to AC (mains) power.

To verify successful DataPort/MCU cable assembly replacement, perform the PVT in [Section 5.2](#) and the DataPort connection and ground continuity test in [Section 5.5](#).

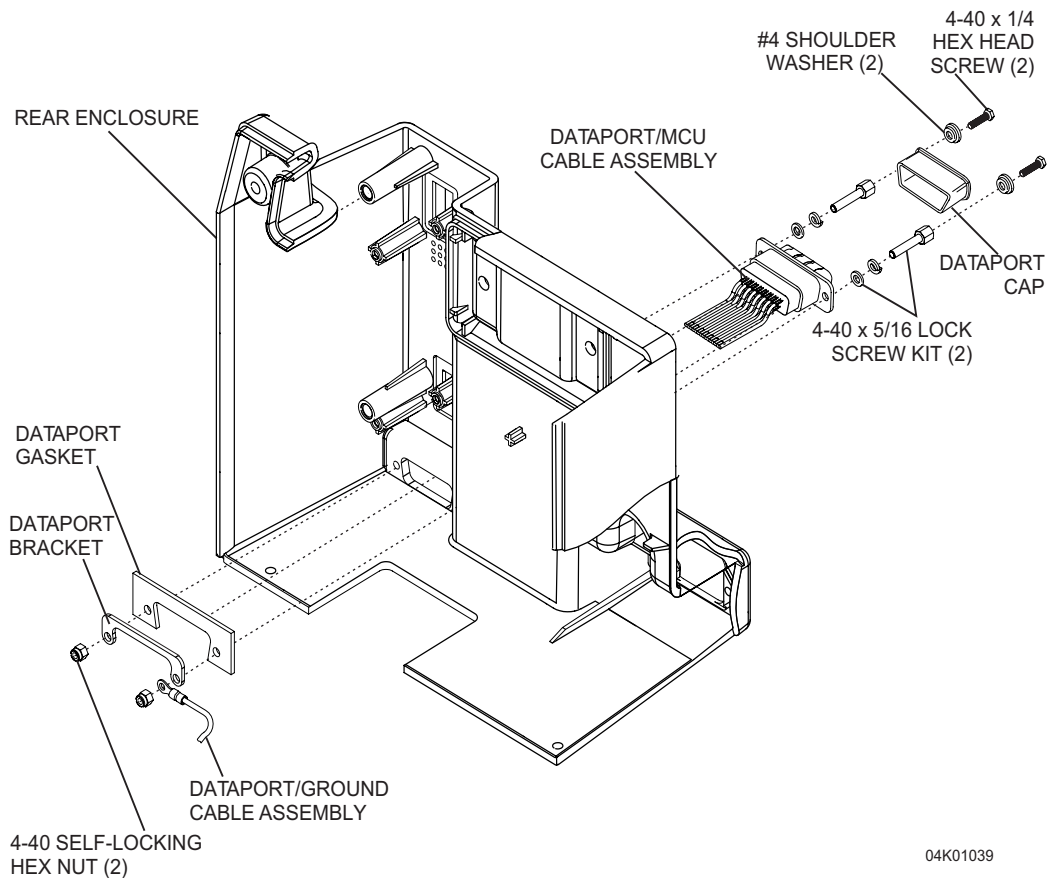

Figure 7-13. DataPort Assembly (International)

7.2.8.10

POLE CLAMP EXTRUSION, POLE CLAMP BACKING PLATE, AND ADHESIVE-BACKED INSULATOR REPLACEMENT

Recommended tools and materials for this procedure are a medium size flat blade screwdriver, a 5/16 inch nutdriver, and mild solvent.

The replacement parts for this procedure are:

**Insulator, Adhesive-Backed
Screw, 10-32 x 1/2, Hex Head, Slotted
Plate, Backing, Pole Clamp
Extrusion, Pole Clamp**

CAUTION: Use proper ESD grounding techniques when handling components. Wear an antistatic wrist strap and use an ESD-protected workstation. Store the PWA in an antistatic bag before placing it on any surface.

To replace the pole clamp extrusion, pole clamp backing plate, and adhesive-backed insulator, refer to [Figure 7-14, XL Series Pole Clamp](#), then proceed as follows:

1. Separate the front enclosure assembly and rear enclosure assembly as described in [Section 7.2.5](#).
2. Remove the power supply PWA as described in [Section 7.2.8.2](#).

3. Grasp the adhesive-backed insulator and remove it from the pole clamp backing plate. Using a mild solvent, clean the pole clamp backing plate.
4. Using a 5/16 inch nutdriver, remove the two hex head screws securing the pole clamp backing plate to the pole clamp extrusion. Remove the pole clamp backing plate and pole clamp extrusion from the rear enclosure assembly.
5. Install the replacement pole clamp extrusion into the rear enclosure assembly.
6. Install the replacement pole clamp backing plate against the pole clamp extrusion. Using a 5/16 inch nutdriver, install and tighten the two hex head screws.
7. Remove the adhesive backing from the replacement insulator. Completely cover the pole clamp backing plate with the replacement insulator. Press firmly to adhere the insulator to the backing plate.

CAUTION: Make sure the insulator covers the entire backing plate. If the backing plate is exposed, the power supply PWA may be damaged when power is applied to the infusion system.

8. Install the power supply PWA in the exact reverse order of removal.
9. Join the front enclosure assembly and rear enclosure assembly in the exact reverse order of separation.

 **Note:** (XLM with DataPort) When joining the front and rear enclosures, do not pinch the DataPort/MCU cable between the two enclosures.

10. Connect the infusion system to AC (mains) power.

To verify successful pole clamp extrusion, backing plate, and insulator replacement, perform the PVT in [Section 5.2](#).

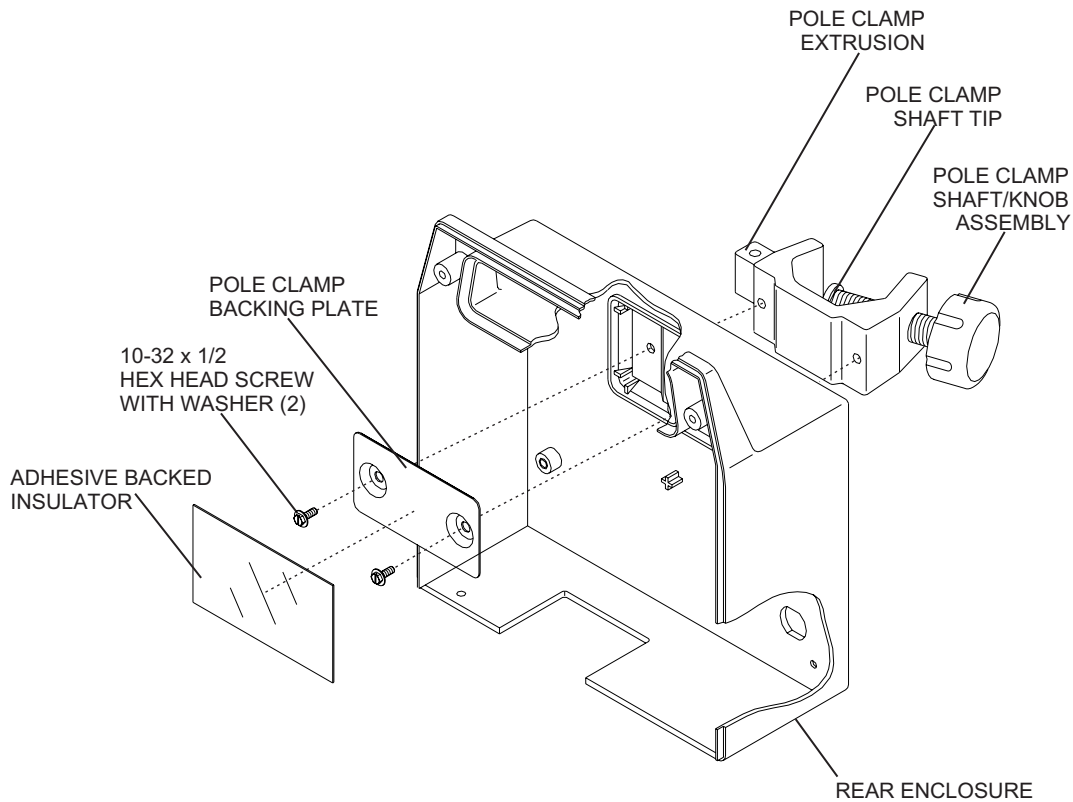

04K01037

Figure 7-14. XL Series Pole Clamp

7.2.8.11

POLE CLAMP SHAFT/KNOB ASSEMBLY AND POLE CLAMP SHAFT TIP REPLACEMENT

The recommended tool for this procedure is wide-head pliers.

The replacement parts for this procedure are:

Assembly, Shaft/Knob, Pole Clamp Tip, Shaft, Pole Clamp

To replace the pole clamp shaft/knob assembly and the pole clamp shaft tip, refer to [Figure 7-14](#), then proceed as follows:

1. Turn the control knob to OFF/CHARGE.
2. Disconnect the infusion system from AC (mains) power.
3. Turn the pole clamp shaft/knob assembly counterclockwise to remove it from the pole clamp extrusion and loosen the pole clamp shaft tip from the pole clamp/shaft knob assembly.

Note: The pole clamp shaft tip has a long shaft that is pressed into the threaded pole clamp shaft/knob assembly.

4. Turn the pole clamp shaft/knob assembly back into the pole clamp extrusion. Using wide-head pliers, grasp the pole clamp shaft tip and remove. Replace the shaft tip if necessary.
5. Install the replacement pole clamp shaft/knob assembly into the pole clamp extrusion by turning the shaft/knob assembly clockwise into the extrusion until the threaded portion is visible.
6. Press the pole clamp shaft tip into the screw hole recess on the pole clamp shaft/knob assembly and turn the shaft/knob assembly clockwise until the shaft tip is secure against the extrusion.
7. Connect the infusion system to AC (mains) power.

Replacement of the pole clamp shaft/knob assembly and the pole clamp shaft tip is a routine maintenance procedure and no verification procedure is normally required. However, if the infusion system may have been damaged during the pole clamp knob and tip insert replacement, perform the PVT in [Section 5.2](#).

7.2.8.12

BUZZER PWA AND MCU/BUZZER CABLE REPLACEMENT

Recommended tools for this procedure are a medium size flat blade screwdriver and a 1/4 inch nutdriver.

The replacement parts for this procedure are:

**PWA, Buzzer
Assembly, Cable, MCU/Buzzer
Gasket, Lockout
Gasket, Audible
Screw, 6-32 x 3/8, Hex Head, Slotted**

CAUTION: Use proper ESD grounding techniques when handling components. Wear an antistatic wrist strap and use an ESD-protected workstation. Store the PWA in an antistatic bag before placing it on any surface.

To replace the buzzer PWA, refer to [Figure 7-15, Buzzer PWA](#), then proceed as follows:

1. Remove the power supply PWA as described in [Section 7.2.8.2](#).
2. Remove the EMI shield.
3. Using a flat blade screwdriver, remove the four slotted hex head screws securing the buzzer PWA to the rear enclosure assembly.
4. Inspect the MCU/Buzzer cable for damage and replace if necessary.
5. Remove the buzzer PWA from the rear enclosure assembly.
6. Inspect the audible gasket and the lockout gasket and replace if necessary ([see Figure 7-15](#)).
7. Install the replacement buzzer PWA.
8. Reassemble the device in the exact reverse order of disassembly.

To verify successful buzzer PWA replacement, perform the PVT in [Section 5.2](#).

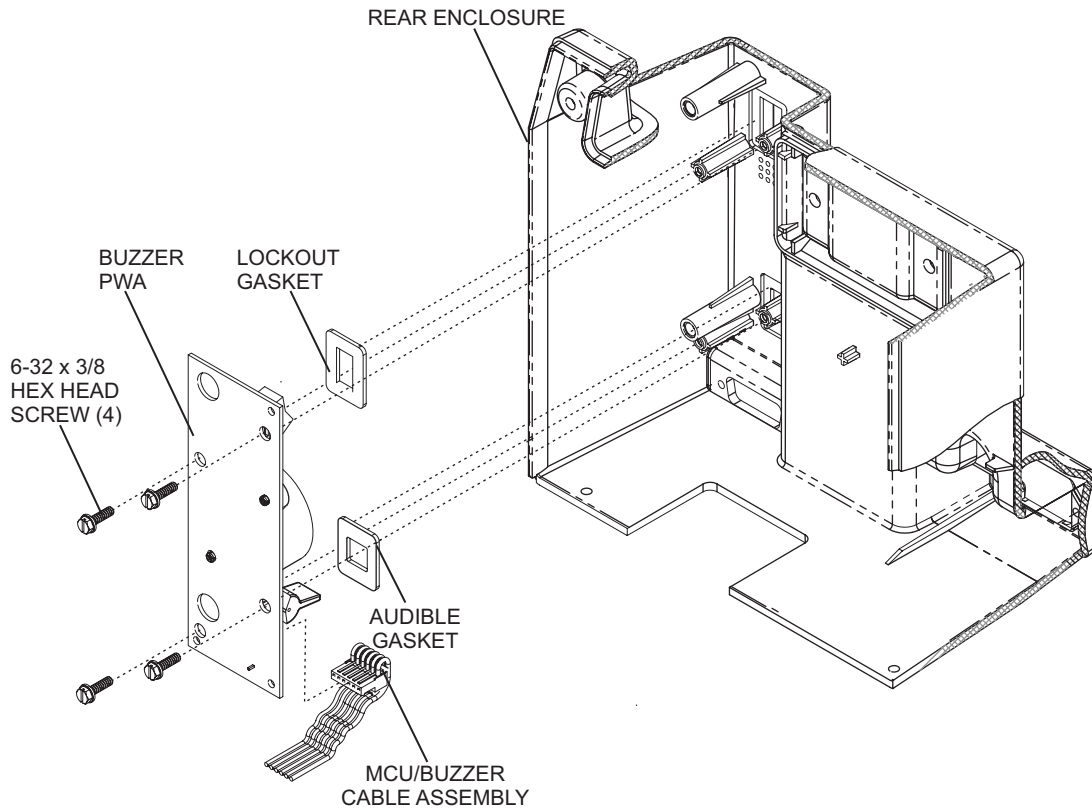

04K01038

Figure 7-15. Buzzer PWA

7.2.9

MAIN CHASSIS ASSEMBLY COMPONENT REPLACEMENT

Main chassis assembly component replacement includes the replacement of the following:

- MCU PWA and sensor/MCU cable assembly
- Mechanism assembly
- Cassette door and mechanism shield
- Opener handle assembly

Note: The MCU PWA is not supplied with the main chassis assembly; however, the MCU PWA is located in the main chassis assembly.

7.2.9.1

MCU PWA AND SENSOR/MCU CABLE ASSEMBLY REPLACEMENT

The recommended tools for this procedure are a medium size flat blade screwdriver, needle nose pliers, and diagonal cutters.

The replacement parts for this procedure are:

**PWA, MCU
Assembly, Cable, Sensor/MCU
Tie, Cable**

CAUTION: Use proper ESD grounding techniques when handling components. Wear an antistatic wrist strap and use an ESD-protected workstation. Store the PWA in an antistatic bag before placing it on any surface.

To replace the MCU PWA and the sensor/MCU cable assembly, refer to [Figure 7-16, Exploded View of the Main Chassis Assembly](#) and [Figure 7-17, Top View of the Main Chassis Assembly](#), then proceed as follows:

1. Separate the front enclosure assembly, rear enclosure assembly, and main chassis assembly as described in [Section 7.2.5](#).
2. Disconnect the following cables from the MCU PWA:
 - sensor/MCU cable assembly from J5
 - plunger motor cable assembly from J7
 - input/output motor cable assembly from J8
 - primary/secondary motor cable assembly from J9.
3. Inspect the cables and replace if necessary.
4. Slide the MCU PWA out of the main chassis assembly.

 **Note:** Some configurations may contain a cable tie securing the MCU PWA to the main chassis. If there is a cable tie present, examine the placement, and, using the diagonal cutters, cut the cable tie to remove the MCU PWA.

5. Install the replacement MCU PWA into the main chassis assembly.
6. Connect the following cables to the MCU PWA:
 - plunger motor cable assembly to J7
 - input/output motor cable assembly to J8
 - primary/secondary motor cable assembly to J9
 - sensor/MCU cable assembly to J5
7. (XLM with DataPort only) Position the ferrite between MCU J5 and the battery compartment. Verify the sensor/MCU cable is looped back to J5 in an 'S' configuration as shown in [Figure 7-17](#).

 **Note:** If the original configuration did not contain the cable tie, proceed to Step 14.

8. To replace the cable tie, hook it around the main chassis boss. Confirm the locking head of the cable tie is located on the right side of the main chassis boss.
9. Connect the MCU PWA securely to the power supply PWA.

10. Insert the pointed end of the cable tie through the corner locating hole of the MCU PWA and loop back around the edge of the PWA.
11. Insert the pointed end of the cable tie into the locking head.
12. Using needle nose pliers, carefully tighten the cable tie until tight.
13. Verify the cable tie is tight and cut away any excess using the diagonal cutters.
14. Reassemble the device in the exact reverse order of disassembly.

Note: (XLM with DataPort) When joining the front and rear enclosures, do not pinch the DataPort/MCU cable between the two enclosures.

15. Connect the infusion system to AC (mains) power.

To verify successful MCU PWA replacement, perform the PVT in [Section 5.2](#).

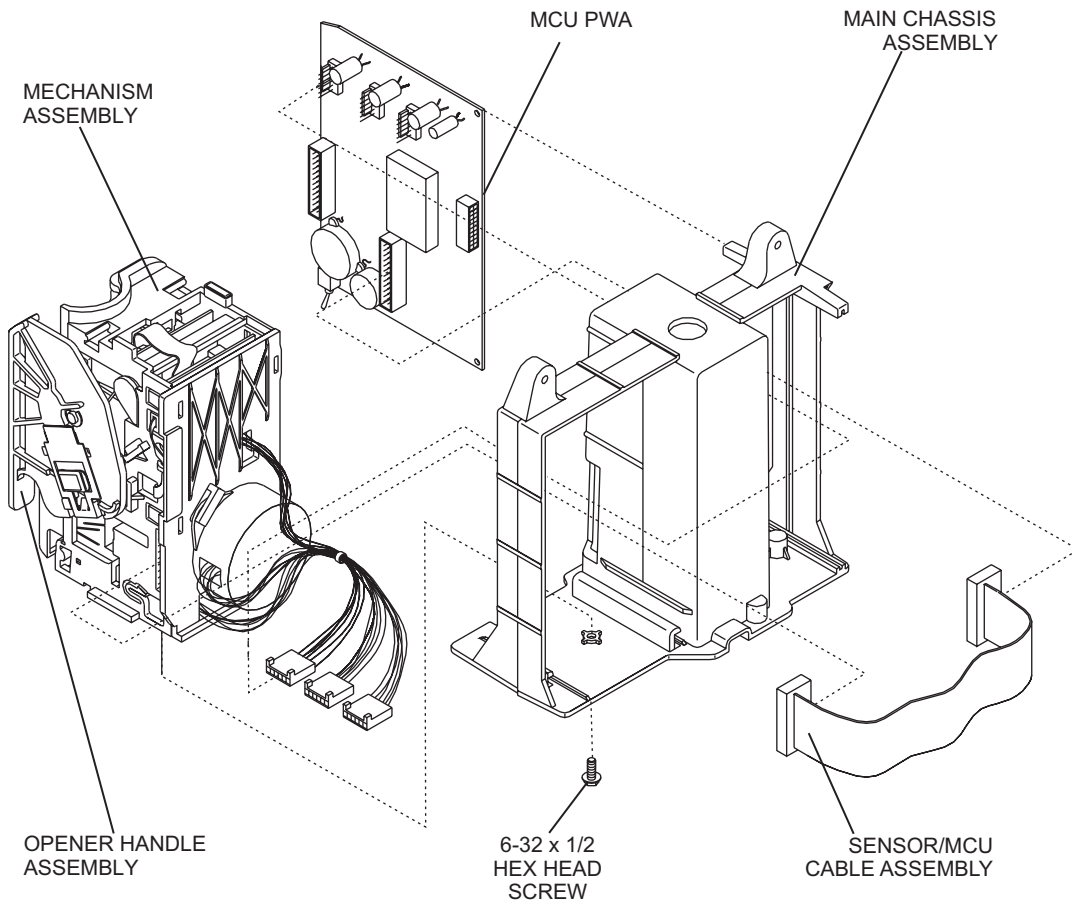

04K01011

Figure 7-16. Exploded View of the Main Chassis Assembly

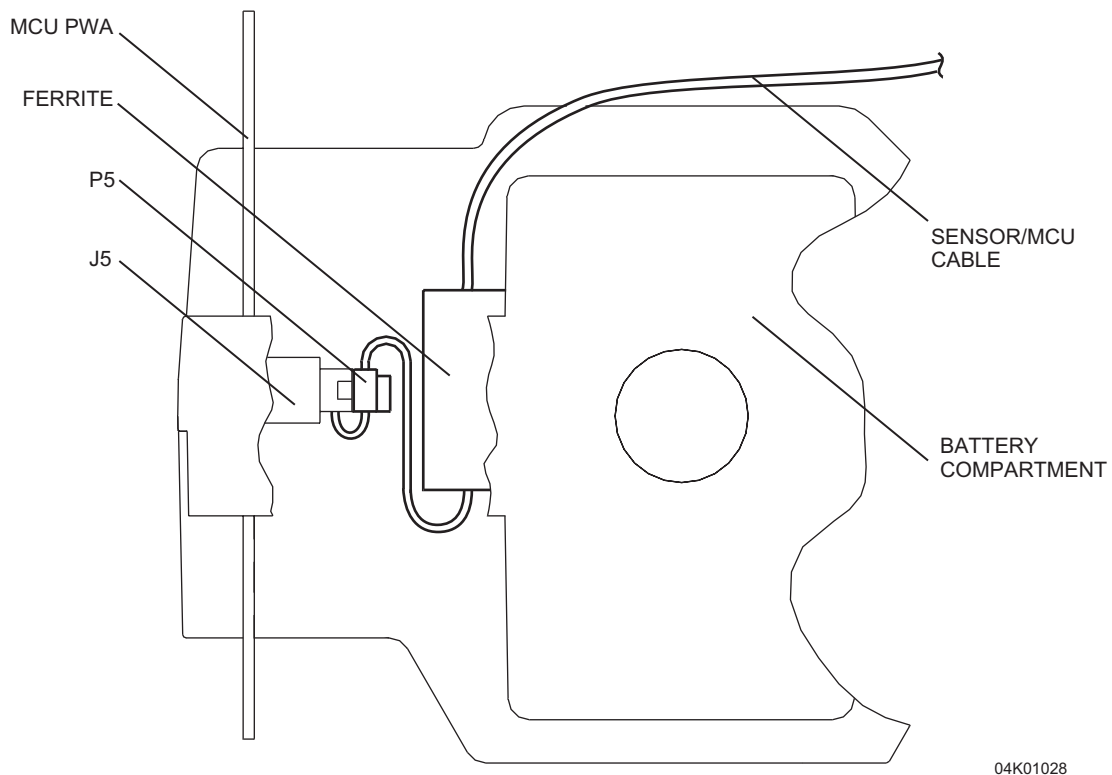

Figure 7-17. Top View of the Main Chassis Assembly

7.2.9.2

MECHANISM ASSEMBLY REPLACEMENT

The recommended tool for this procedure are diagonal cutters and a medium size flat blade screwdriver.

The replacement parts for this procedure are:

Assembly, Mechanism
Screw, 6-32 x 1/2, Hex Head, Slotted
Tie, Cable
Mount, Cable Tie, Adhesive-Back

CAUTION: Use proper ESD grounding techniques when handling components. Wear an antistatic wrist strap and use an ESD-protected workstation. Store the PWA in an antistatic bag before placing it on any surface.

To replace the mechanism assembly, refer to [Figure 7-16](#), then proceed as follows:

1. Separate the front enclosure assembly, rear enclosure assembly, and main chassis assembly as described in [Section 7.2.5](#).

2. Remove the MCU PWA as described in [Section 7.2.9.1](#). Disconnect the sensor/MCU cable assembly from the mechanism assembly at J6.
3. Using a medium size flat blade screwdriver, remove the hex head screw securing the mechanism assembly to the main chassis assembly.

 **Note:** (International devices only) Use the diagonal cutters to cut the cable tie holding the mechanism assembly cables to the main chassis assembly. Inspect the cable tie mount and replace if damaged.

4. Remove the mechanism assembly from the main chassis assembly.
5. Using a medium size flat blade screwdriver, replace and tighten the hex head screw to secure the replacement mechanism assembly to the main chassis assembly.
6. Connect the sensor/MCU cable assembly to the replacement mechanism assembly at J6. Replace the MCU PWA in the exact reverse order of removal.
7. Join the front enclosure assembly, rear enclosure assembly, and main chassis assembly in the exact reverse order of separation.

 **Note:** (XLM with DataPort) When joining the front and rear enclosures, do not pinch the DataPort/MCU cable between the two enclosures.

8. Connect the infusion system to AC (mains) power.
9. (XLM with DataPort only) Perform the following steps to verify proper operation of the DataPort:
 - Enter the service mode as described in [Section 6.2.3](#).
 - Verify the value of the communication selection as described in [Section 6.2.3.4.1](#). Update the value if necessary.
 - Verify the value of the channel label as described in [Section 6.2.3.4.3](#). Update the value if necessary.

To verify successful mechanism assembly replacement, perform the PVT in [Section 5.2](#).

7.2.9.3

CASSETTE DOOR AND MECHANISM SHIELD REPLACEMENT

Recommended tools for this procedure are a medium size flat blade screwdriver and long needle nose pliers.

The replacement parts for this procedure are:

**Shield, Mechanism
Retainer, Door Pivot
Spring, Door Clip, Left-Side
Assembly, Door**

CAUTION: Use proper ESD grounding techniques when handling components. Wear an antistatic wrist strap and use an ESD-protected workstation. Store the PWA in an antistatic bag before placing it on any surface.

To replace the cassette door and mechanism shield, refer to [Figure 7-18, Mechanism Shield Replacement](#); [Figure 7-19](#) through [Figure 7-21, Cassette Door Replacement \(3 of 3\)](#); and [Figure 7-22, Cassette Door Replacement, Bottom View](#), then proceed as follows:

1. Separate the front enclosure assembly, rear enclosure assembly, and main chassis assembly as described in [Section 7.2.5](#).

2. Remove the mechanism assembly from the main chassis assembly as described in [Section 7.2.9.2](#).
3. Open the cassette door. Disengage and fully open the cassette door from the opener handle assembly (*see Figure 7-18*).
4. On the backside of the mechanism shield, disengage the clips that retain the upper portion of the mechanism shield to the mechanism assembly. Pull the shield away from the top of the mechanism assembly at an approximate 15-degree angle. Pull shield up and away, clearing the mechanism assembly pins and plunger.
5. Close the cassette door.
6. Position the mechanism assembly to access its bottom.
7. Grasp the cassette door pivot retainer clip sides and squeeze together to free the side flanges from the mechanism assembly (*see Figure 7-19* through *Figure 7-22*). Once flanges are free, grasp the cassette door pivot retainer clip with needle nose pliers. Simultaneously pull out and rotate the cassette door retainer clip toward the cassette door.

 **Note:** When removing the cassette door, the left side door clip may fall free. Verify the position of the left side door clip prior to cassette door removal.

8. Fully open the cassette door. Note the position of the left-side door clip. Grasp the mechanism assembly in one hand and with the other hand, rotate and lift the cassette door free of the left-side door clip. Remove the cassette door from the hinge.
9. Install the replacement cassette door in the exact reverse order of the cassette door removal.

 **Note:** Prior to mechanism shield replacement, align the mechanism assembly pins.

10. Install the replacement mechanism shield in the exact reverse order of removal.
11. Reassemble the device in the exact reverse order of disassembly.

 **Note:** (XLM with DataPort) When joining the front and rear enclosures, do not pinch the DataPort/MCU cable between the two enclosures.

12. Connect the infusion system to AC (mains) power.

To verify successful cassette door and mechanism shield replacement, perform the PVT in [Section 5.2](#).

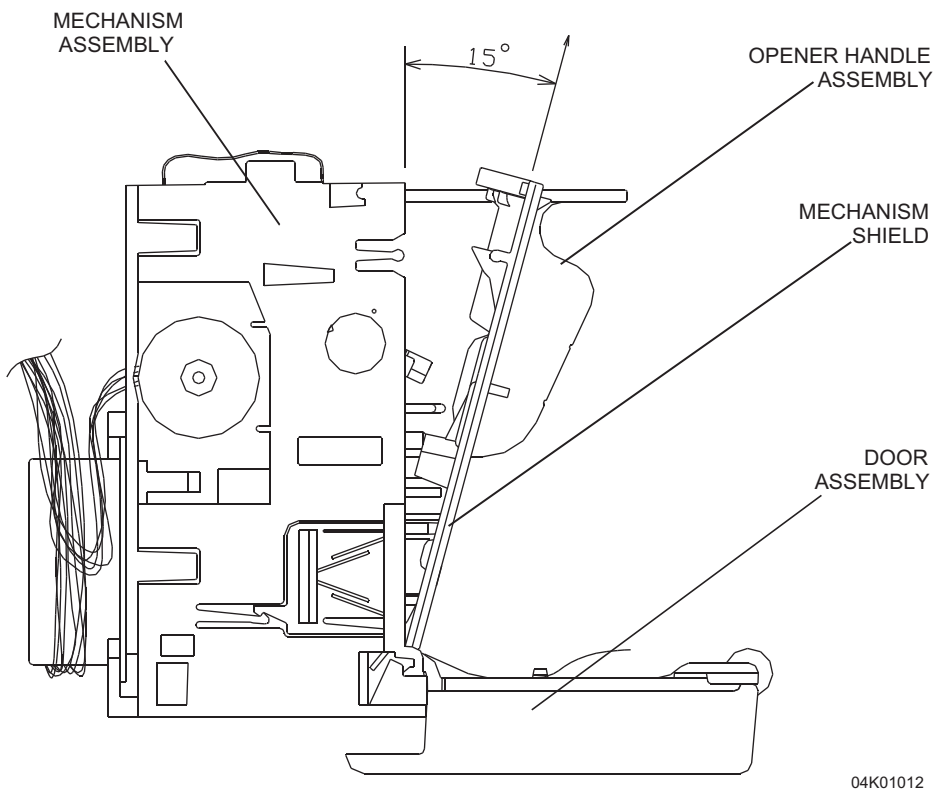

04K01012

Figure 7-18. Mechanism Shield Replacement

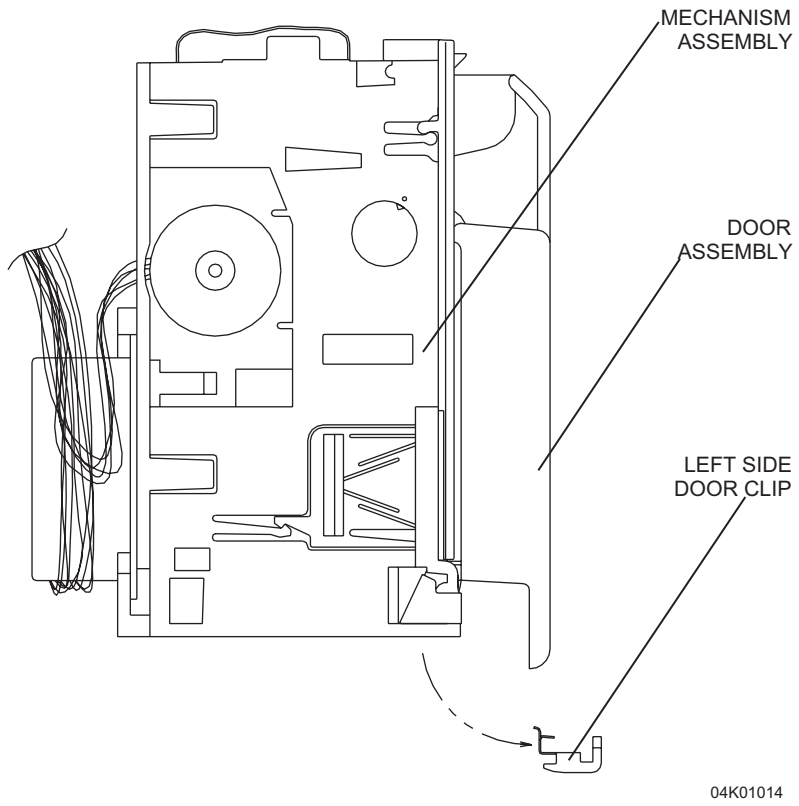

Figure 7-19. Cassette Door Replacement (1 of 3)

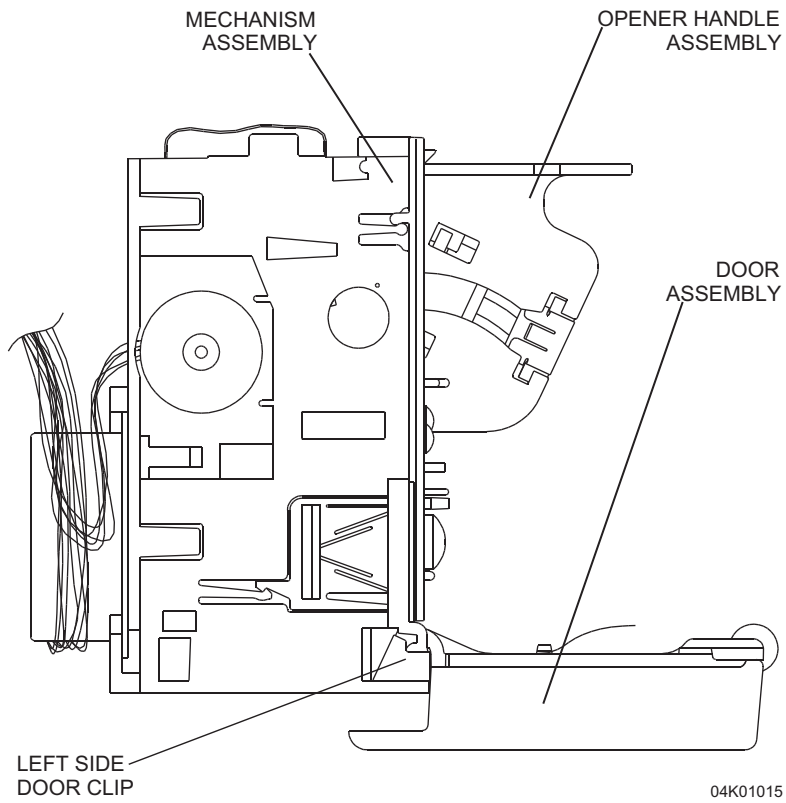

Figure 7-20. Cassette Door Replacement (2 of 3)

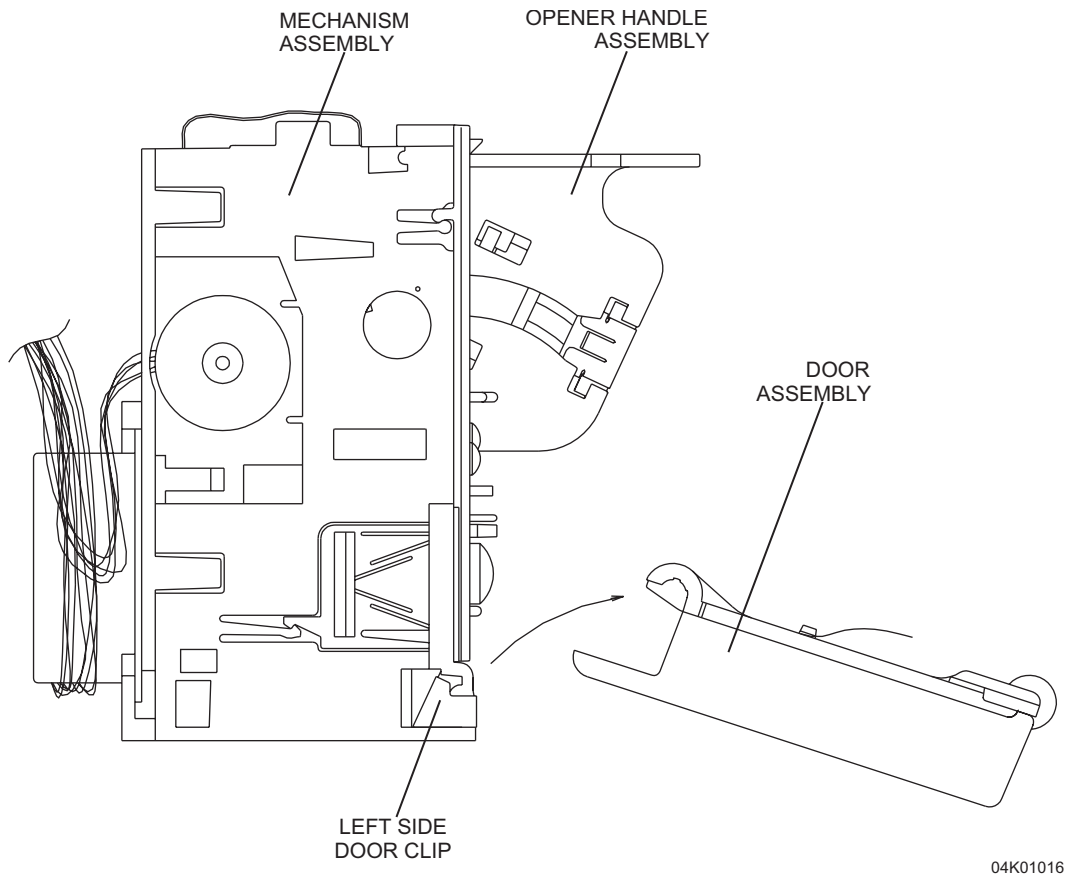

Figure 7-21. Cassette Door Replacement (3 of 3)

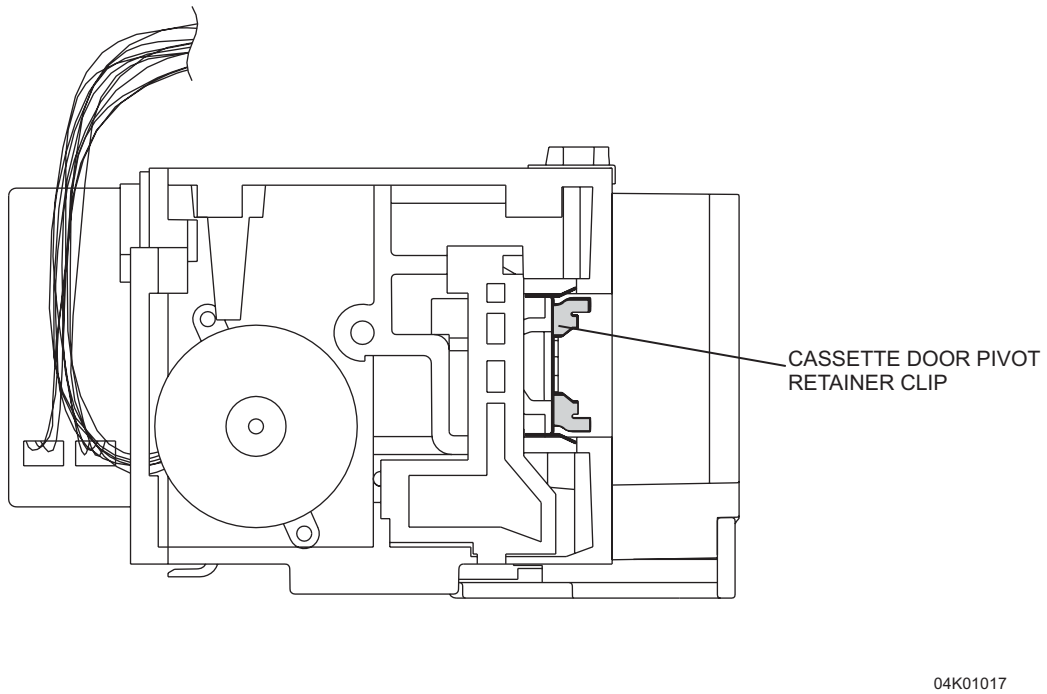

Figure 7-22. Cassette Door Replacement, Bottom View

7.2.9.4**OPENER HANDLE ASSEMBLY REPLACEMENT**

The recommended tool for this procedure is a medium size flat blade screwdriver.

The replacement parts for this procedure are:

Ring, Retaining
Roller, Handle
Holder, Handle Spring
Spring, Torsion
Assembly, Opener/Handle

CAUTION: Use proper ESD grounding techniques when handling components. Wear an antistatic wrist strap and use an ESD-protected workstation. Store the PWA in an antistatic bag before placing it on any surface.

To replace the opener handle assembly, refer to [Figure 7-23, Opener Handle Assembly Replacement \(1 of 3\)](#) through [Figure 7-25, Opener Handle Assembly Replacement \(3 of 3\)](#), then proceed as follows:

1. Separate the front enclosure assembly, rear enclosure assembly, and main chassis assembly as described in [Section 7.2.5](#).
2. Remove the mechanism assembly as described in [Section 7.2.9.2](#).
3. Lift the opener handle assembly. Open and disengage the cassette door. Close the opener handle assembly.
4. Remove the retaining ring.
5. Insert the medium size flat blade screwdriver between the opener handle assembly and the mechanism assembly. Carefully pry the assemblies apart. Remove the handle roller from the backside of the opener handle assembly as the opener handle is removed.

 **Note:** The handle spring holder and torsion spring may fall free.

6. Install the replacement opener handle assembly in the exact reverse order of removal. Confirm that the shaft alignment dots are aligned ([see Figure 7-25](#)).
7. Replace the mechanism assembly in the exact reverse order of removal.
8. Join the front enclosure assembly, rear enclosure assembly, and main chassis assembly in the exact reverse order of separation.

 **Note:** (XLM with DataPort) When joining the front and rear enclosures, do not pinch the DataPort/MCU cable between the two enclosures.

9. Connect the infusion system to AC (mains) power.

To verify successful opener handle assembly replacement, perform the PVT in [Section 5.2](#).

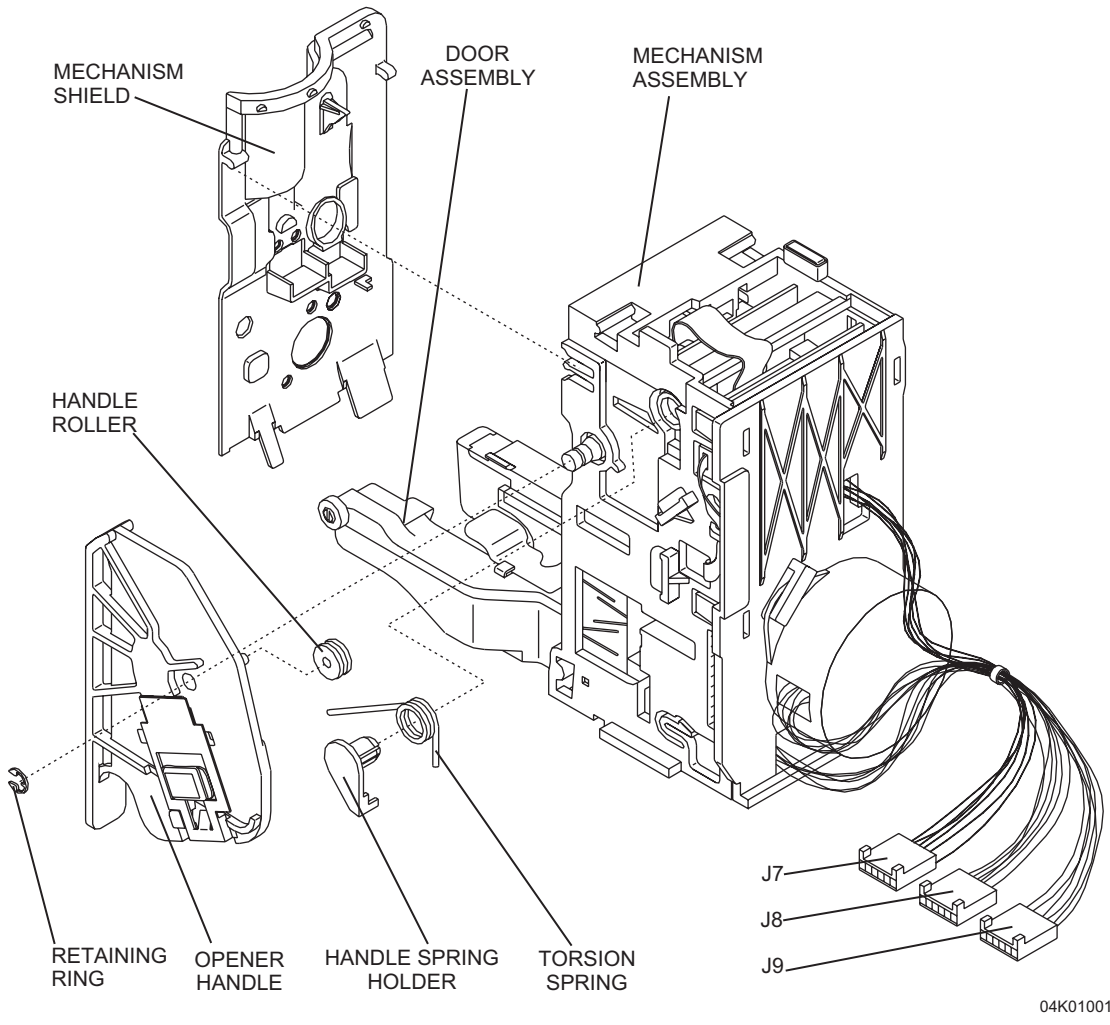

Figure 7-23. Opener Handle Assembly Replacement (1 of 3)

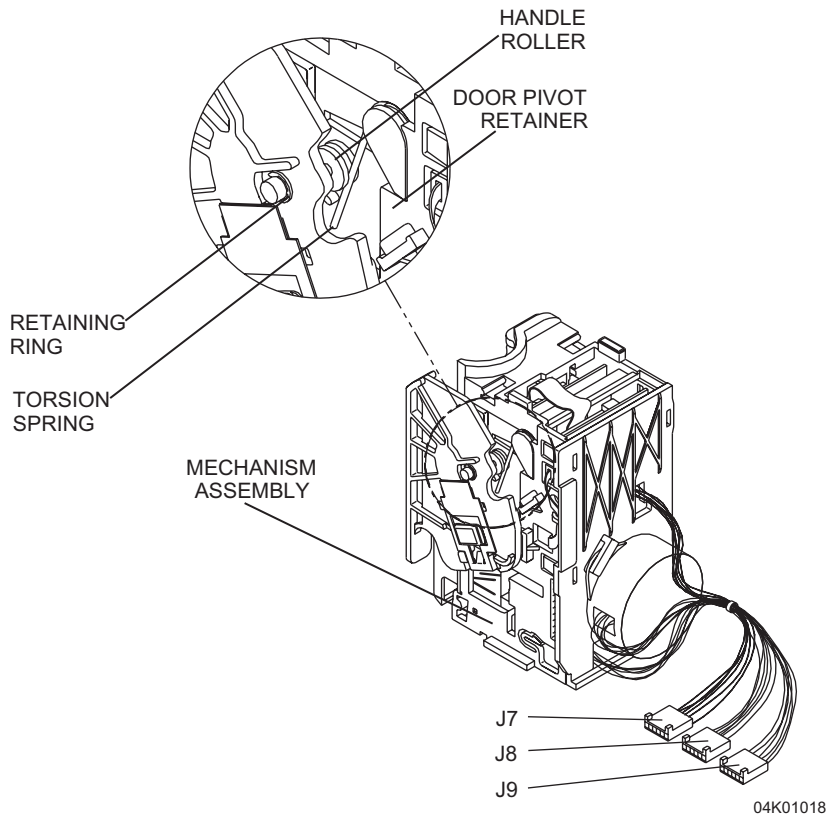

Figure 7-24. Opener Handle Assembly Replacement (2 of 3)

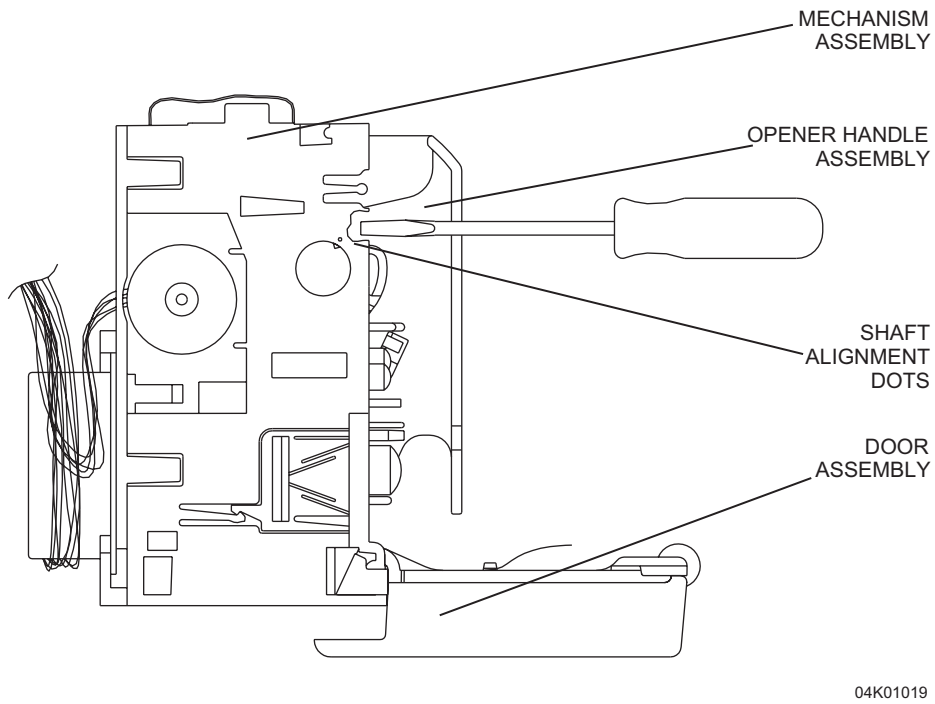

Figure 7-25. Opener Handle Assembly Replacement (3 of 3)

This page intentionally left blank.

Section 8

SPECIFICATIONS

This section contains specifications for the 115 VAC Plum XL and 220 VAC LifeCare XL infusion systems.

8.1

PLUM XL AND XLM



The following specifications apply to the Plum XL infusion system only.

PHYSICAL

Dimensions: Approximately 8.25H x 7.5W x 8.75D inches (including pole clamp)

Weight: Approximately 7.75 lbs (with battery)

Casing: High-impact plastic

ELECTRICAL

Power Requirements: 100-130 VAC, 50 to 60 Hz, less than 35 W

Power Cord: Hospital-grade AC (mains) cord. 10 feet long, with transparent plug

Fuses: 0.5 A, 250 V, slo-blo

Battery: Sealed lead-acid, rechargeable 8 V battery, internal to infusion system. Accessible for ease of field replacement, with color-coded leads and polarized connector

Battery Operation

(XL/XLM): A fully charged new battery provides eight hours of operation at 125 mL/hr, or 1000 mL total volume delivered, whichever occurs first

Battery Operation (XLM with DataPort)

With DataPort circuitry disabled, a fully charged new battery provides eight hours of operation at 125 mL/hr, or 1000 mL total volume delivered, whichever occurs first. With DataPort enabled, a fully charged new battery provides approximately five hours of operation at 125 mL/hr, or 625 mL total volume delivered, whichever occurs first

Note: Do not connect DataPort when infusing

Recharge: The battery charges whenever the infusion system is connected to AC (mains) power. If the infusion system is operating at 125 mL/hr, a full recharge takes approximately 16 hours. If the infusion system is turned to OFF/CHARGE, recharge takes approximately eight hours

ENVIRONMENT**Operating Temperature:** 0° to 40° C, 10% to 90% relative humidity**TRANSPORT AND
STORAGE
ENVIRONMENT****Temperature:** -20° to 60° C**Relative Humidity:** 10% to 90%**Atmospheric Pressure:** 0-10,000 feet (0-3,000m) or equivalent pressure**DELIVERY RATE RANGE****Primary, Secondary
Mode****XL:** 1 to 999 mL/hr (in 1 mL increments)**XLM:** 0.1 to 99.9 mL/hr (in 0.1 mL increments)
100 to 999 mL/hr (in 1 mL increments)**KVO****XL:** 1 mL/hr**XLM:** The lower of 1.0 mL/hr or the last rate delivered**DOSE LIMIT RANGE****XL:** 1 to 9999 mL/hr (in 1 mL increments)**XLM:** 0.1 to 99.9 mL (in 0.1 mL increments)
100 to 9999 mL (in 1 mL increments)**OCCCLUSION RANGE****Distal:** 10 psi (+5, -2 psi)**8.2****LIFECARE XL AND XLM**

The following specifications apply to the LifeCare XL infusion system only.

PHYSICAL**Dimensions:** 21 x 19 x 22 cm**Weight:** Approximately 3.5 kg (with battery)**Casing:** High-impact plastic**ELECTRICAL****Mains Voltage:** 210-260 VAC, 47 - 63 Hz, 35 VA, or 100-130 VAC,
47 - 63 Hz, 35 VA**Mains Fusing:** Two each: T500 mA, 250 V, 5 x 20 mm**Mains Cord:**  IEC 60601-1 approved, removable cord, maximum
3 m in length, >HAR<

Battery: One 8 V, sealed, rechargeable battery, internal to the infusion system. Accessible for ease of field replacement, with color-coded leads and polarized connector

Battery Operating Time

(XL/XLM): With a new, fully charged battery, the infusion system provides approximately 1000 mL delivery volume or eight hours of operation, whichever occurs first. The infusion system displays a low battery alarm approximately 30 minutes prior to infusion system shutdown when pumping at 125 mL/hr. If a low battery alarm occurs, immediately connect the infusion system to mains power

Note: Gradual degradation over extended periods of use decreases the operational capacity of the battery. Typical battery life is three years. A yearly check is recommended to verify performance. When capacity drops to an unacceptable level, replace the battery. Battery replacement must be performed by qualified technical personnel

Battery Operating Time

(XLM with DataPort): With DataPort circuitry disabled, a fully charged new battery provides eight hours of operation, or 1000 mL total volume delivered, whichever occurs first. With DataPort enabled, a fully charged new battery provides approximately five hours of operation, or 625 mL total volume delivered, whichever occurs first. The infusion system displays a low battery alarm approximately 30 minutes prior to infusion system shutdown when pumping at 125 mL/hr. If a low battery alarm occurs, immediately connect the infusion system to mains power

Note: Do not connect DataPort when infusing

Note: Gradual degradation over extended periods of use decreases the operational capacity of the battery. Typical battery life is three years. A yearly check is recommended to verify performance. When capacity drops to an unacceptable level, replace the battery. Battery replacement must be performed by qualified technical personnel

Battery Recharge: The battery recharges when the infusion system is connected to mains power. If the infusion system is operating at 125 mL/hr, a full recharge takes approximately 16 hours. Recharge takes approximately eight hours if the infusion system is turned to the OFF/CHARGE position

Battery Charge

Retention: A fully charged battery retains at least 20 percent of its capacity after six months of storage at below 35° C (95° F) in an infusion system not connected to mains power

ENVIRONMENT

Operating Temperature: 0° to 40° C (50° to 104° F) 10 percent to 90 percent relative humidity

Shipping and Storage: -20° to 60° C (-4° to 140° F) 10 percent to 90 percent relative humidity

DELIVERY RATE RANGE

Flow Rate Range

XL: 1 to 999 mL/hr (in 1 mL increments)

XLM: 0.1 to 99.9 mL/hr (in 0.1 mL increments)
100 to 999 mL/hr (in 1 mL increments)

KVO

XL: 1 mL/hr

XLM: The lower of 1.0 mL/hr or the last rate delivered

DOSE LIMIT RANGE

XL: 1 to 9999 mL/hr (in 1 mL increments)

XLM: 0.1 to 99.9 mL (in 0.1 mL increments)
100 to 9999 mL (in 1 mL increments)

ELECTRONIC MEMORY: Rates, dose limits, and total volume delivered are maintained indefinitely

ELECTRICAL SAFETY: Designed to meet IEC 60601-1-2 standards



Attention! Consult accompanying documents



Terminal for connection of an equipotential conductor

MAXIMUM OCCLUSION

PRESSURE: 99 kPa

OCCLUSION ALARM

PRESSURE LIMIT: 69 ± 14 kPa

MAXIMUM

OVERINFUSION: The maximum overinfusion under single fault conditions is 25 percent

MAXIMUM STORED

BOLUS VOLUME:

Delivery Rate: 1 mL/hr = 0.6 mL
100 mL/hr = 0.6 mL
999 mL/hr = 0.6 mL

**MAXIMUM TIME FROM
OCCLUSION TO ALARM:**

Delivery Rate:
1 mL/hr = 40 minutes
100 mL/hr = 30 seconds
999 mL/hr = 2 seconds

DELIVERY RATE

ACCURACY: ± 5 percent in typical clinical use

Section 9

DRAWINGS

[Figure 9-1](#) through [Figure 9-28](#) show the illustrated parts breakdown (IPB), block diagram, and PWA schematic diagrams. [Table 9-1, Drawings](#), lists drawings by figure number, title, and part number. [Table 9-2, IPB for the Infusion System](#), identifies parts by index numbers which correlate to [Figure 9-1](#).

 **Note:** Drawings and schematics in [Section 9](#) are provided as information only, and may not exactly reflect current product configuration.

| Figure No. | Title | Part Number |
|----------------------|--|--------------------|
| 9-1 | Illustrated Parts Breakdown (2 sheets) | Not Applicable |
| 9-2 | Front Enclosure, Rear Enclosure, and Main Chassis Assemblies | |
| 9-3 | Front Enclosure Assembly | |
| 9-4 | Rear Enclosure Assembly (XL - Domestic) | |
| 9-5 | Rear Enclosure Assembly (XL - International) | |
| 9-6 | Rear Enclosure Assembly (XLM - Domestic) | |
| 9-7 | Rear Enclosure Assembly (XLM - International) | |
| 9-8 | Rear Enclosure Assembly (XLM with DataPort - Domestic) | |
| 9-9 | Rear Enclosure Assembly (XLM with DataPort - International) | |
| 9-10 | Rear Enclosure Assembly (LifeCare XLM with DataPort) | |
| 9-11 | Main Chassis Assembly | |
| 9-12 | Battery Replacement | |
| 9-13 | Mechanical Assembly (2 sheets) | |
| 9-14 | Plum XL Block Diagram | |
| 9-15 | MCU PWA Schematic (XL) (2 sheets) | 249-00530 |
| 9-16 | MCU PWA Schematic (XLM) (2 sheets) | 249-05907 |
| 9-17 | MCU PWA Schematic (XLM with DataPort) (18 sheets) | 249-05701 |

| Table 9-1. Drawings | | |
|----------------------------|--|--------------------|
| Figure No. | Title | Part Number |
| 9-18 | Display PWA Schematic (XL) | 249-00531 |
| 9-19 | Display PWA Schematic (XLM) (7 sheets) | 249-05901 |
| 9-20 | Bubble Sensor PWA Schematic (3 sheets) | 249-00536 |
| 9-21 | Sensor PWA Schematic | 249-00538 |
| 9-22 | Pin Detector Flex Circuit Schematic | 249-00539 |
| 9-23 | Power Supply PWA Schematic (XL - Domestic) (2 sheets) | 249-00562 |
| 9-24 | Power Supply PWA Schematic (XL - International) (2 sheets) | 249-00573 |
| 9-25 | Power Supply PWA Schematic (XLM - Domestic) (2 sheets) | 249-05920 |
| 9-26 | Power Supply PWA Schematic (XLM - International) (4 sheets) | 249-05916 |
| 9-27 | Power Supply PWA Schematic (XLM with DataPort) (4 sheets) | 249-05916 |
| 9-28 | Buzzer PWA Schematic | 249-05903 |

| Table 9-2. IPB for the Infusion System | | |
|---|--|----------------------------------|
| Index No. | Nomenclature | Replacement Procedure |
| 1 | Enclosure, Front | Section 7.2.6 |
| 2 | Chassis, Main | Section 7.2.6 |
| 3 | Enclosure, Rear | Section 7.2.6 |
| 4 | PWA, Power Supply | Section 7.2.8.2 |
| 5 | Shield, EMI | Section 7.2.8.7 |
| 6 | PWA, MCU | Section 7.2.9.1 |
| 7 | PWA, Display | Section 7.2.7.1 |
| 8 | Assembly, Mechanism | Section 7.2.9.2 |
| 9 | Assembly, Opener Handle | Section 7.2.9.4 |
| 10 | PWA, Buzzer | Section 7.2.8.12 |
| 11 | Shield, Mechanism | Section 7.2.9.3 |
| 12 | Label, Front Panel | Section 7.2.7.4 |
| 13 | Cordset, AC Power, Hospital Grade, 220 V | Section 7.2.8.5 |
| 14 | Cordset, AC Power, Hospital Grade, 115 V | Section 7.2.8.4 |

Table 9-2. IPB for the Infusion System

| Index No. | Nomenclature | Replacement Procedure |
|------------------|---|----------------------------------|
| 15 | Assembly, Battery, with Wire Harness | Section 7.2.4 |
| 16 | Door, Battery | Section 7.2.4 |
| 17 | Pad, Battery Door | Section 7.2.4 |
| 18 | Insulator, Adhesive-Backed | Section 7.2.8.10 |
| 19 | Plate, Backing, Pole Clamp | Section 7.2.8.10 |
| 20 | Extrusion, Pole Clamp | Section 7.2.8.10 |
| 21 | Tip, Shaft, Pole Clamp | Section 7.2.8.11 |
| 22 | Assembly, Shaft/Knob, Pole Clamp | Section 7.2.8.11 |
| 23 | Assembly, Cable, MCU/Display | Section 7.2.7.1 |
| 24 | Assembly, Cable, Sensor/MCU | Section 7.2.9.1 |
| 25 | Assembly, Ground Wire | As Applicable |
| 26 | Assembly, Cable, DataPort/Ground | Section 7.2.8.8 |
| 27 | Assembly, Cable, DataPort/MCU | Section 7.2.8.8 |
| 28 | Assembly, Cable, MCU/Buzzer | Section 7.2.8.12 |
| 29 | Strap, Velcro, 1.75 in. x 10 in., Black | Section 7.2.8.3 |
| 30 | Gasket, Front/Rear Enclosure | Section 7.2.6 |
| 31 | Gasket, Front/Rear Enclosure | Section 7.2.6 |
| 32 | Knob, Control | Section 7.2.7.3 |
| 33 | Washer, Knob | Section 7.2.7.3 |
| 34 | Gasket, Knob | Section 7.2.7.3 |
| 35 | Ring, Detent | Section 7.2.7.3 |
| 36 | Detent, Knob | Section 7.2.7.3 |
| 37 | Shim, Knob | Section 7.2.7.3 |
| 38 | Assembly, Cassette Door | Section 7.2.9.3 |
| 39 | Connector, AC Receptacle, 220 V | Section 7.2.8.6 |
| 40 | Connector, AC Receptacle, International | Section 7.2.8.7 |
| 41 | Strain Relief, Nylon, Black | Section 7.2.8.4 |
| 42 | Key, Front Panel, Switch-Activated | Section 7.2.7.2 |
| 43 | Fuse, 0.5 A, 250 V, Slo-Blo, 5 x 20 mm | Section 7.2.8.1 |
| 44 | Cover, Fuse, 5 x 20 mm | Section 7.2.8.1 |
| 45 | Ring, Retaining, .188 x .025 Thk., SS | Section 7.2.9.4 |

Table 9-2. IPB for the Infusion System

| Index No. | Nomenclature | Replacement Procedure |
|------------------|--|--|
| 46 | Roller, Handle | Section 7.2.9.4 |
| 47 | Holder, Handle Spring | Section 7.2.9.4 |
| 48 | Spring, Torsion | Section 7.2.9.4 |
| 49 | Retainer, Door Pivot | Section 7.2.9.3 |
| 50 | Retainer, Snap, Knob | Section 7.2.7.3 |
| 51 | Magnet | Section 7.2.7.3 |
| 52 | Spring, Door Clip, Left-Side | Section 7.2.9.3 |
| 53 | Foot, Rubber | Section 7.2.3 |
| 54 | Gasket, Lockout | Section 7.2.8.12 |
| 55 | Gasket, Audible | Section 7.2.8.12 |
| 56 | Housing, Seal, AC Receptacle | Section 7.2.8.7 |
| 57 | Gasket, AC Receptacle | Section 7.2.8.7 |
| 58 | Bracket, AC Receptacle | Section 7.2.8.7 |
| 59 | Gasket, DataPort | Section 7.2.8.9 |
| 60 | Bracket, DataPort | Section 7.2.8.9 |
| 61 | Post, Equipotential | Section 7.2.8.6 , Section 7.2.8.7 |
| 62 | Bumper, XL MCU | Section 7.2.7.1 |
| 63 | Screw, 6-32 x 1/2, Hex Head, Slotted, with Washer | As Applicable |
| 64 | Screw, 10-32 x 1/2, Hex Head, Slotted, with Washer | As Applicable |
| 65 | Screw, 6-32 x 5/16, Hex Head, Slotted, with Washer | As Applicable |
| 66 | Screw, 4-24 x 3/8, B/Point, Phillips | As Applicable |
| 67 | Screw, 6-32 x 3/4, Hex Head, Slotted, with Washer | As Applicable |
| 68 | Screw, 6-32 x 3/8, Slotted, Type T | As Applicable |
| 69 | Screw, 6-32 x 1, Hex Head, Slotted, with Washer | As Applicable |
| 70 | Kit, Screw, Lock, 4-40 x .312 | As Applicable |
| 71 | Kit, Screw, Lock, 4-40 | As Applicable |
| 72 | Nut, KEP, 6-32 | As Applicable |
| 73 | Nut, Hex, Metric, DIN 934, 6mm | As Applicable |
| 74 | Nut, Hex, Metric, DIN 439, 6mm | As Applicable |
| 75 | Nut, Hex, Self-Locking, 4-40 | As Applicable |

Table 9-2. IPB for the Infusion System

| Index No. | Nomenclature | Replacement Procedure |
|------------------|--|---|
| 76 | Washer, Lock, 1/4, Internal Tooth, .025 Thk. | As Applicable |
| 77 | Washer, Flat, .147 x .032 Thk., Brass | As Applicable |
| 78 | Washer, Flat, .253 x .050 Thk. | As Applicable |
| 79 | Washer, Flat, .566 x .255 x .030 Thk., SS | As Applicable |
| 80 | Cable Tie | <i>Section 7.2.9.1, Section 7.2.9.2</i> |
| 81 | Mount, Cable Tie, Adhesive Back | <i>Section 7.2.9.2</i> |
| 82 | Screw, 4-40 x 1/4, Hex Head, Nylon | <i>Section 7.2.8.9</i> |
| 83 | Washer, Shoulder, #4, Nylon | <i>Section 7.2.8.9</i> |
| 84 | Cap, DataPort | <i>Section 7.2.8.9</i> |

This page intentionally left blank.

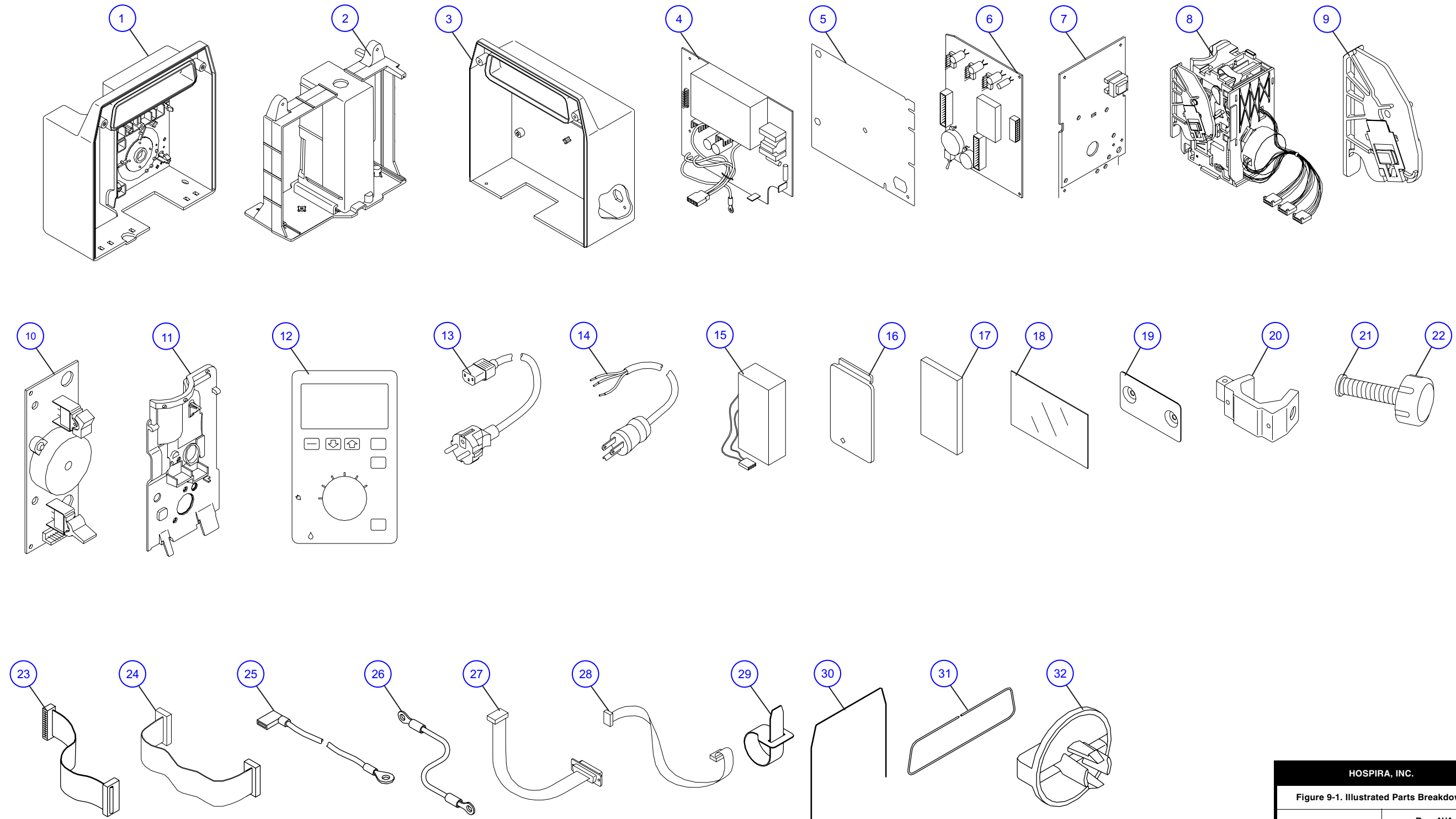

04K04002

| | |
|---|--------------|
| HOSPIRA, INC. | |
| Figure 9-1. Illustrated Parts Breakdown | |
| DRAWING NO. | Rev. N/A |
| NOT APPLICABLE | Sheet 1 of 2 |

This page intentionally left blank.

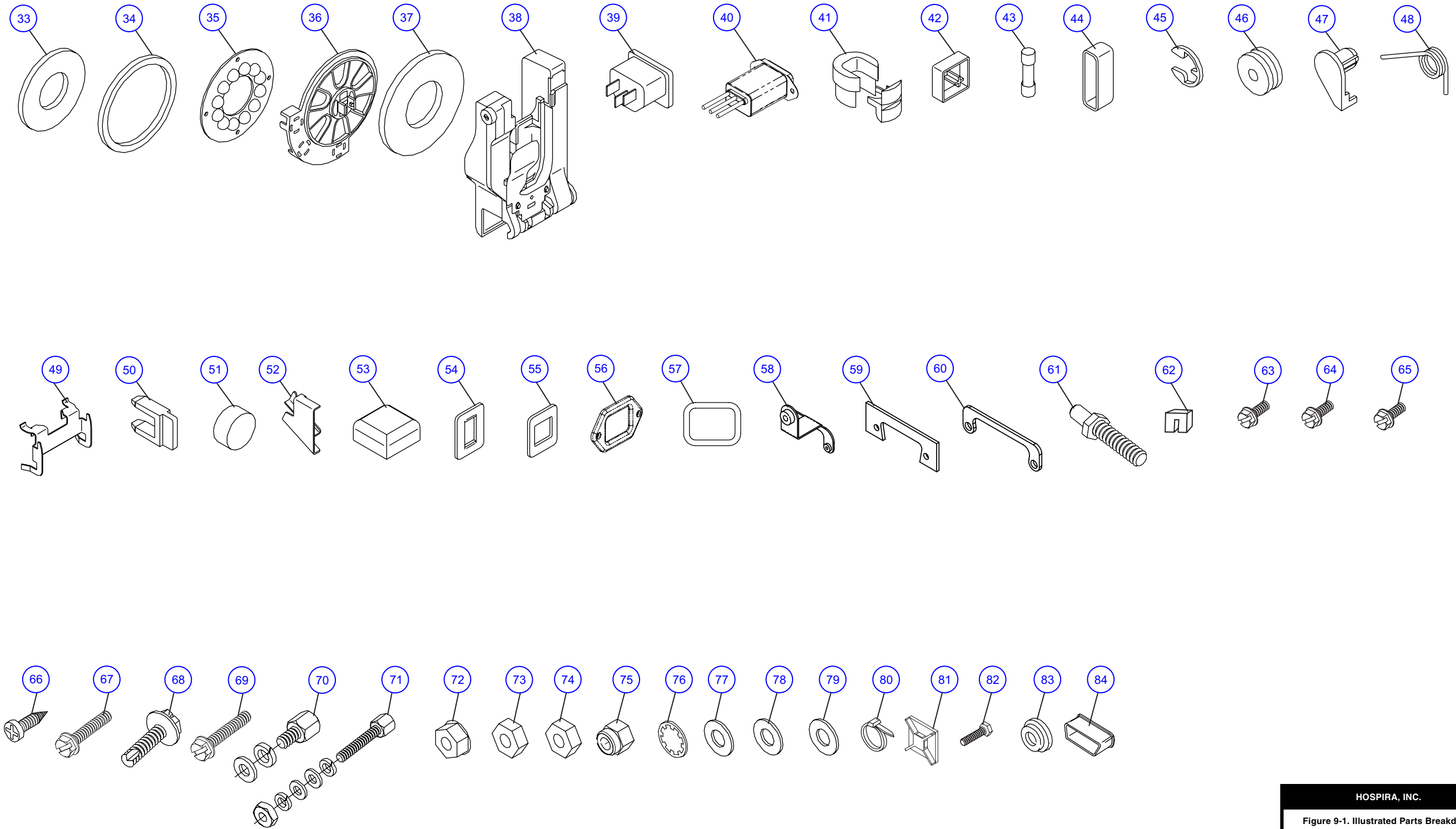

04K04001

| | |
|---|--------------|
| HOSPIRA, INC. | |
| Figure 9-1. Illustrated Parts Breakdown | |
| DRAWING NO. | Rev. N/A |
| NOT APPLICABLE | Sheet 2 of 2 |

This page intentionally left blank.

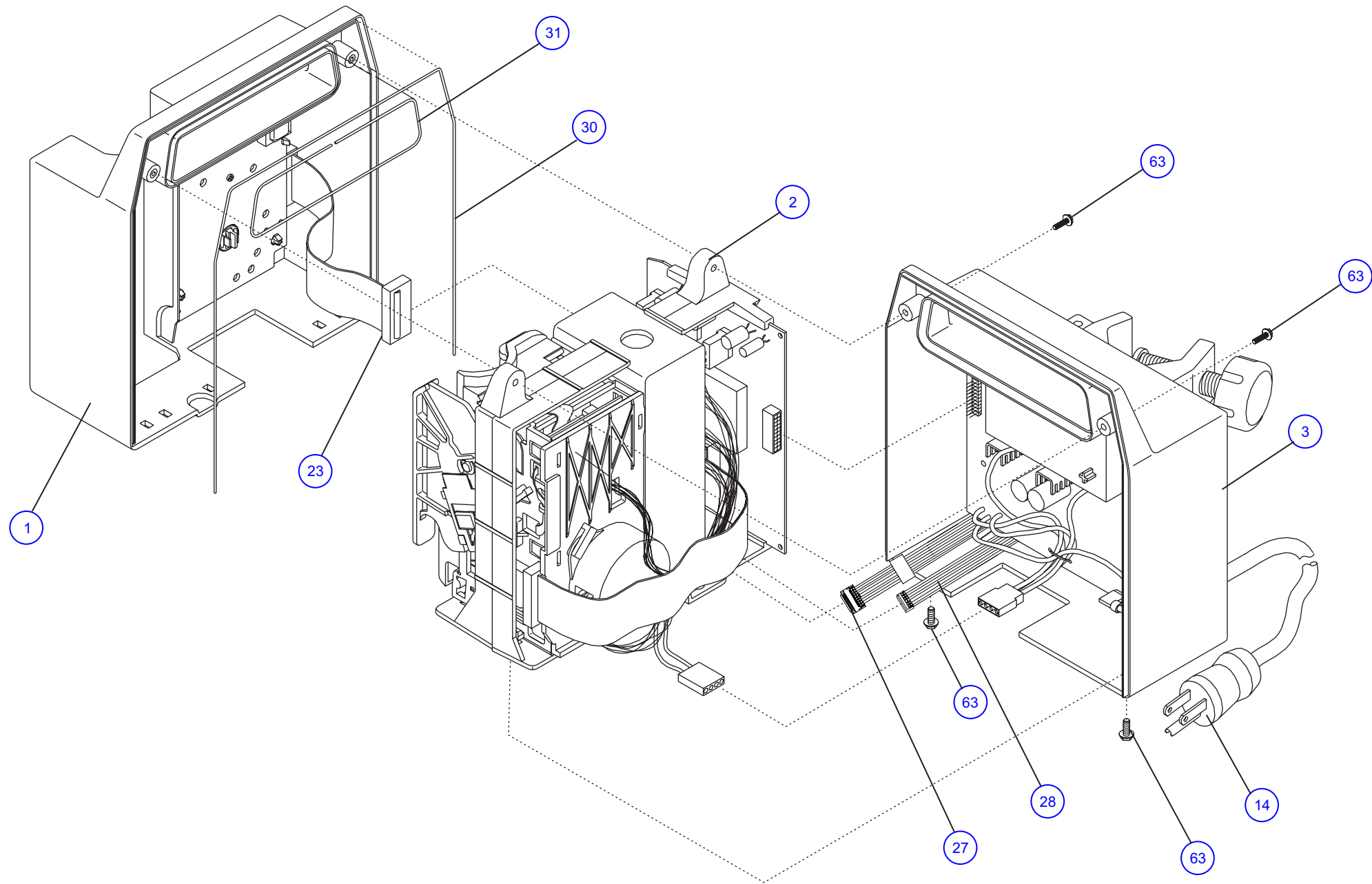

04K04007

| | |
|---|--------------|
| HOSPIRA, INC. | |
| Figure 9-2. Front Enclosure, Rear Enclosure, and Main Chassis Assemblies | |
| DRAWING NO. | Rev. N/A |
| NOT APPLICABLE | Sheet 1 of 1 |

This page intentionally left blank.

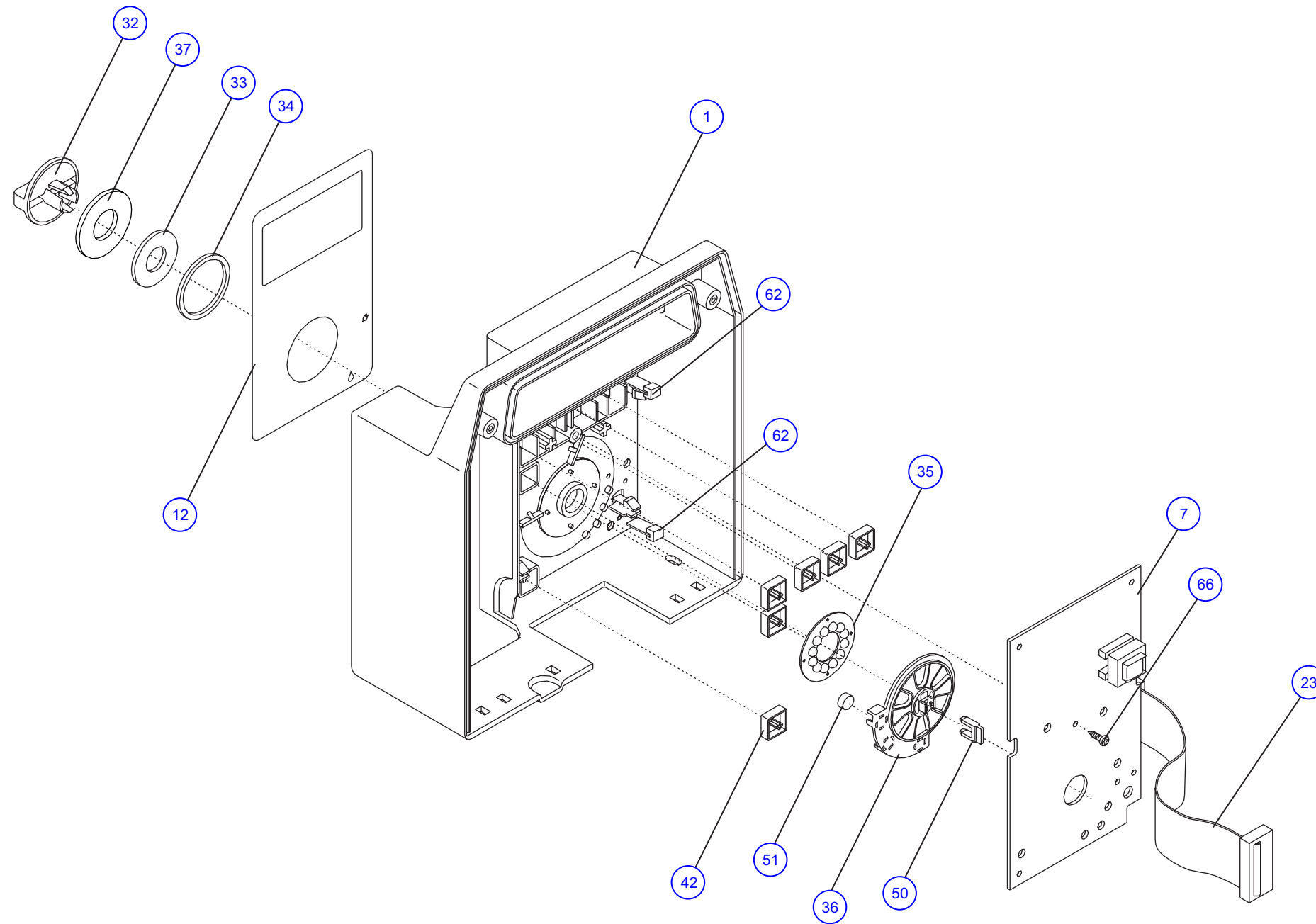

04K03002

| | |
|--------------------------------------|--------------|
| HOSPIRA, INC. | |
| Figure 9-3. Front Enclosure Assembly | |
| DRAWING NO. | Rev. N/A |
| NOT APPLICABLE | Sheet 1 of 1 |

This page intentionally left blank.

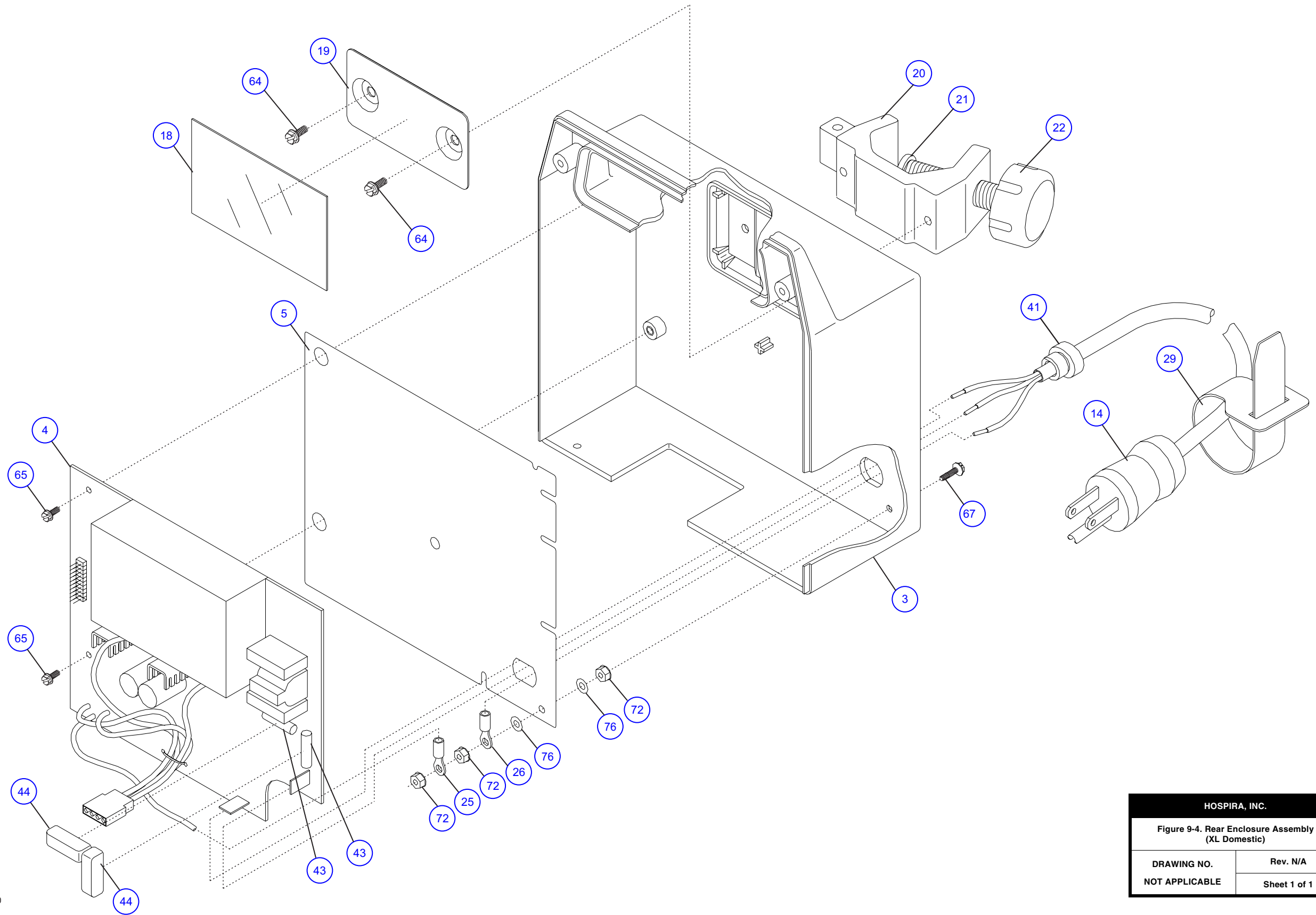

04K04010

| | |
|--|--------------------------|
| HOSPIRA, INC. | |
| Figure 9-4. Rear Enclosure Assembly (XL Domestic) | |
| DRAWING NO. NOT APPLICABLE | Rev. N/A Sheet 1 of 1 |

This page intentionally left blank.

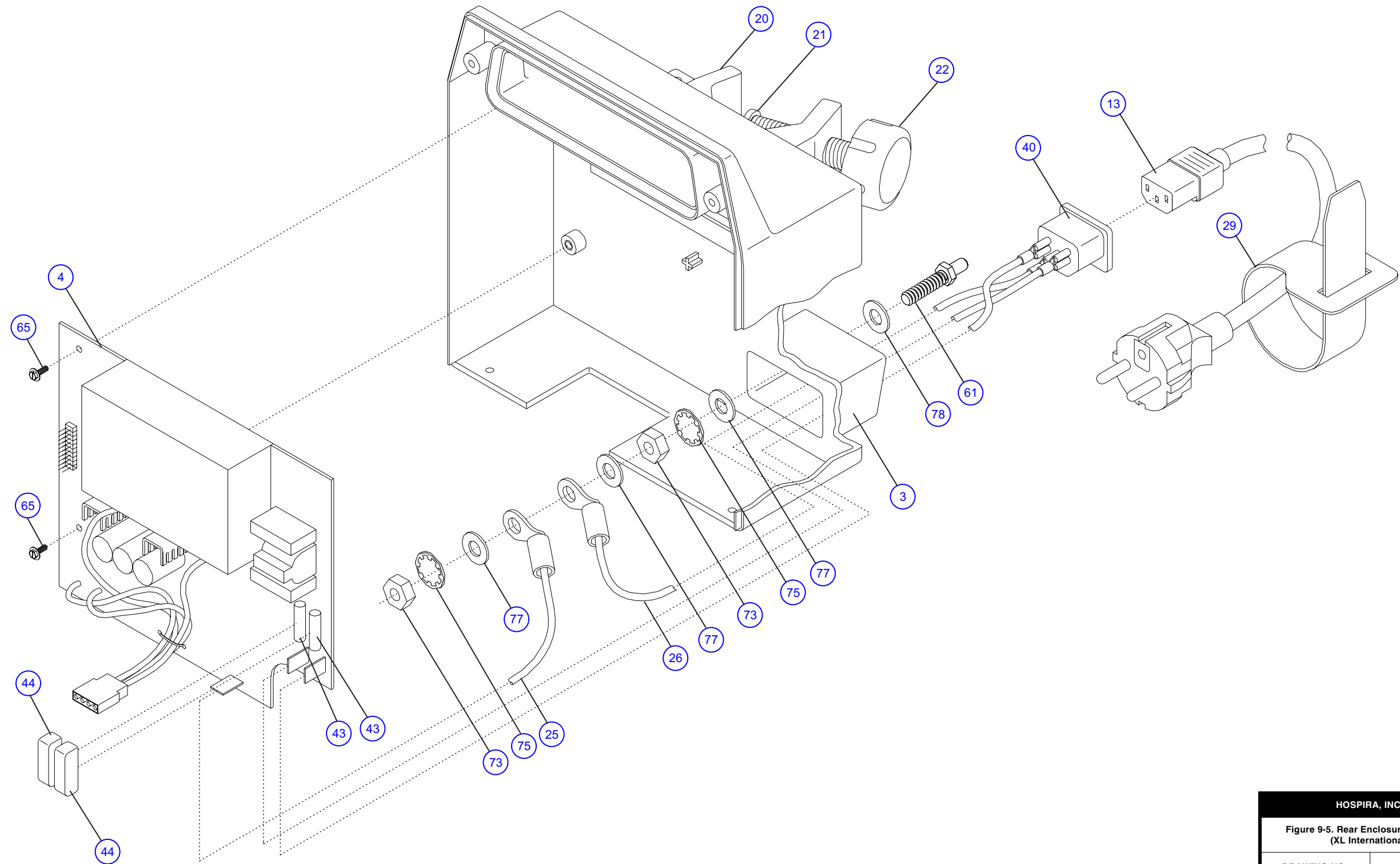

04K04011

| | |
|---|--------------------------|
| HOSPIRA, INC. | |
| Figure 9-5. Rear Enclosure Assembly (XL International) | |
| DRAWING NO. NOT APPLICABLE | Rev. N/A Sheet 1 of 1 |

This page intentionally left blank.

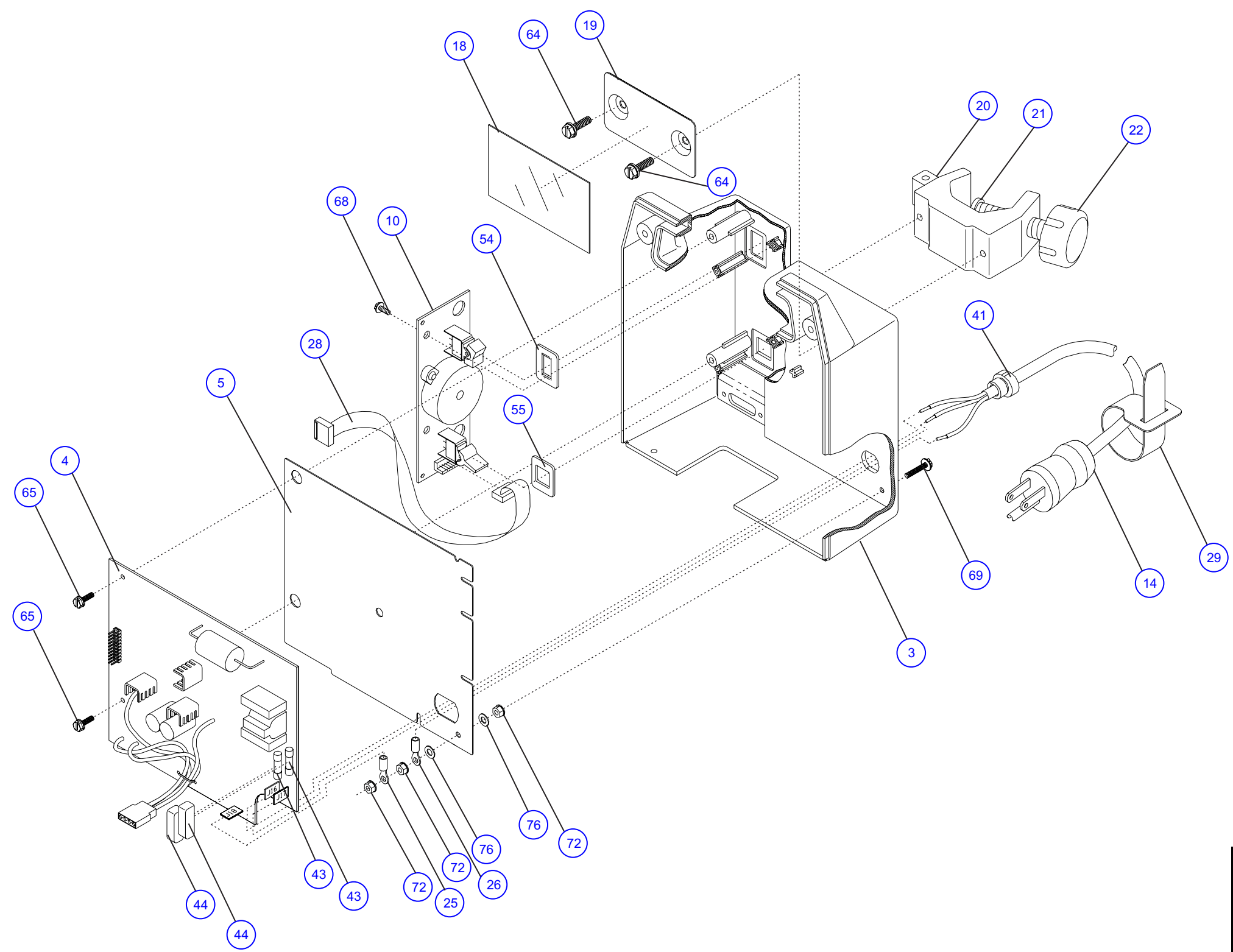

04K04005

| | |
|---|--------------|
| HOSPIRA, INC. | |
| Figure 9-6. Rear Enclosure Assembly (XLM Domestic) | |
| DRAWING NO. | Rev. N/A |
| NOT APPLICABLE | Sheet 1 of 1 |

This page intentionally left blank.

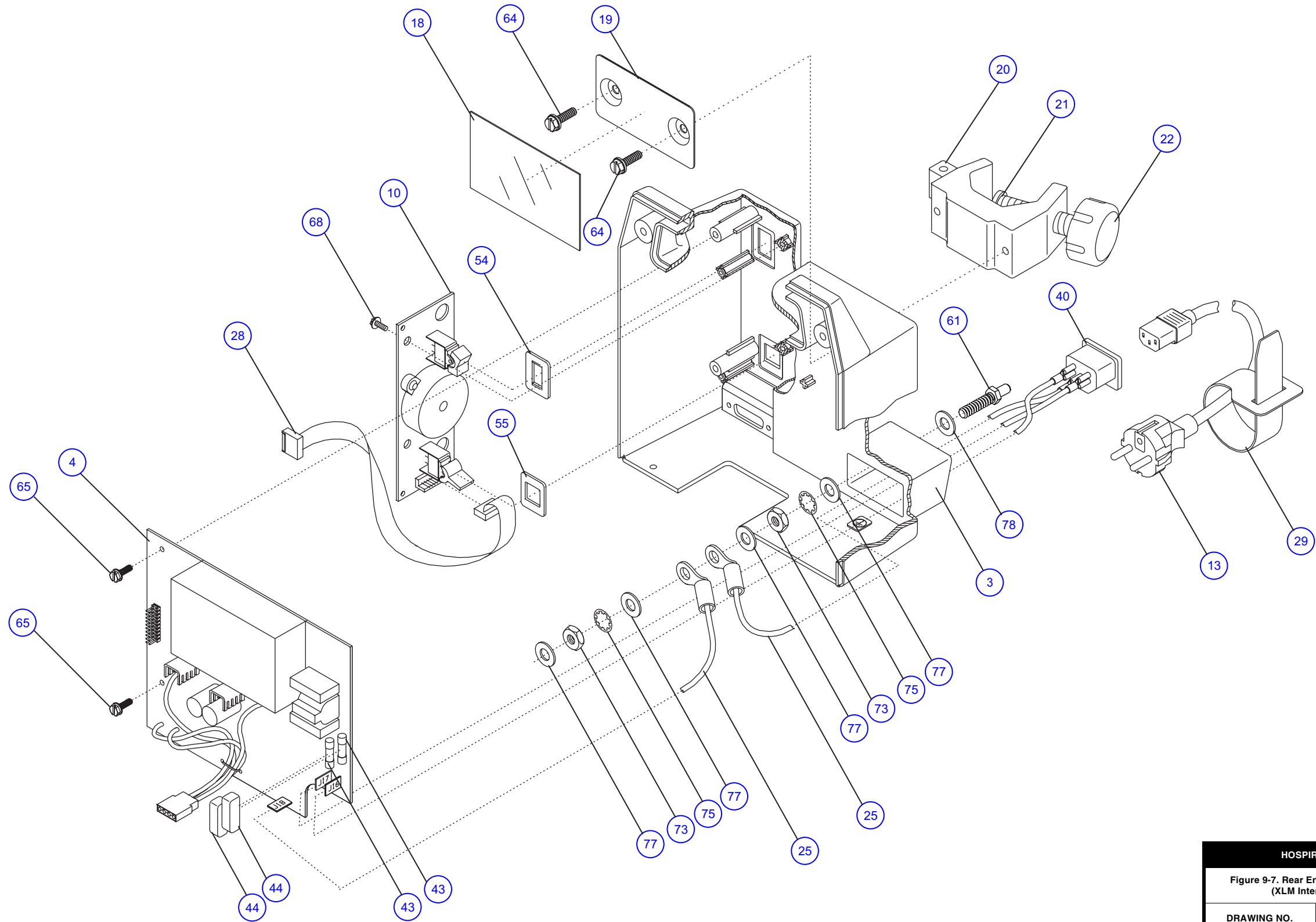

04K04006

| | |
|--|--------------------------|
| HOSPIRA, INC. | |
| Figure 9-7. Rear Enclosure Assembly (XLM International) | |
| DRAWING NO. NOT APPLICABLE | Rev. N/A Sheet 1 of 1 |

This page intentionally left blank.

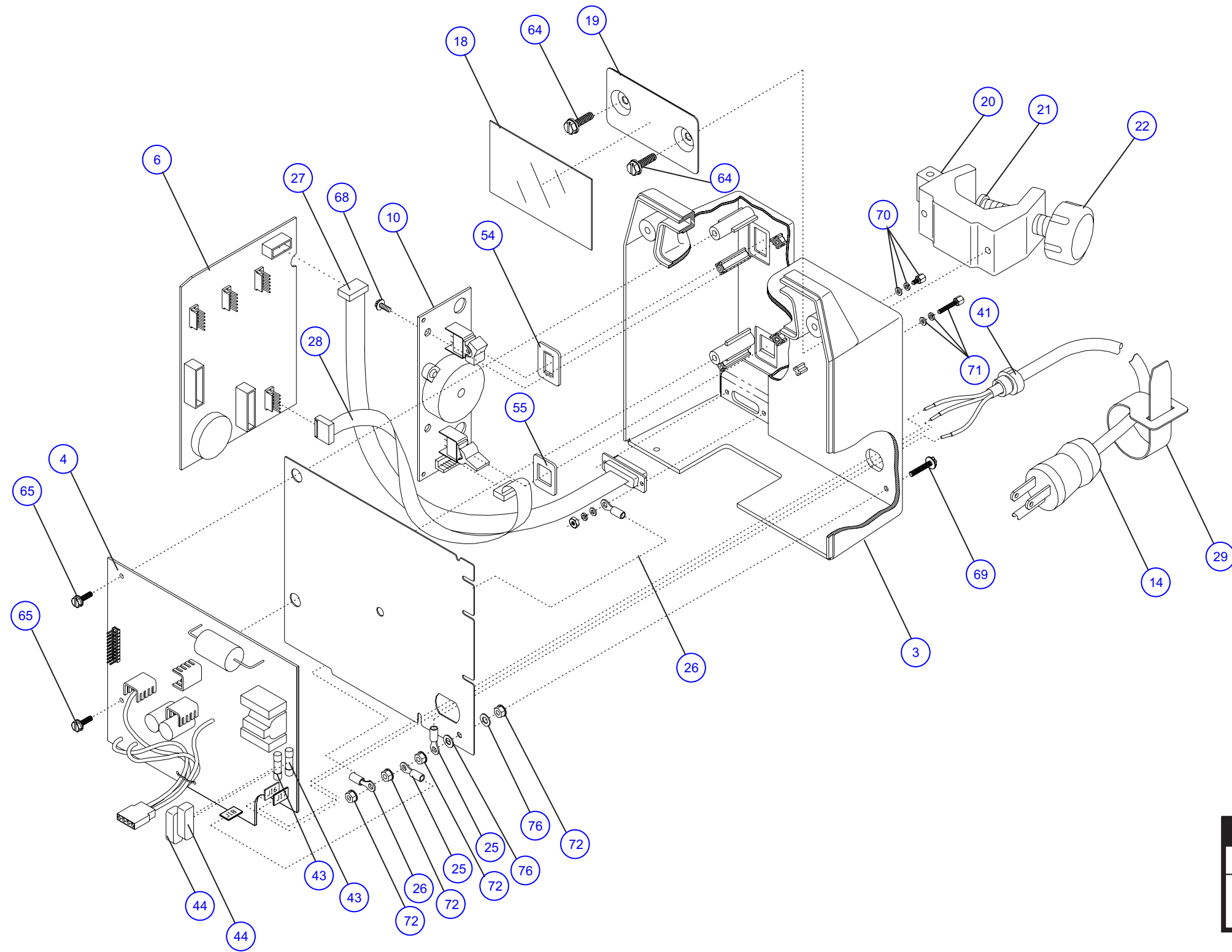

04K04003

| | |
|---|--------------------------|
| HOSPIRA, INC. | |
| Figure 9-8. Rear Enclosure Assembly (XLM with DataPort - Domestic) | |
| DRAWING NO. NOT APPLICABLE | Rev. N/A Sheet 1 of 1 |

This page intentionally left blank.

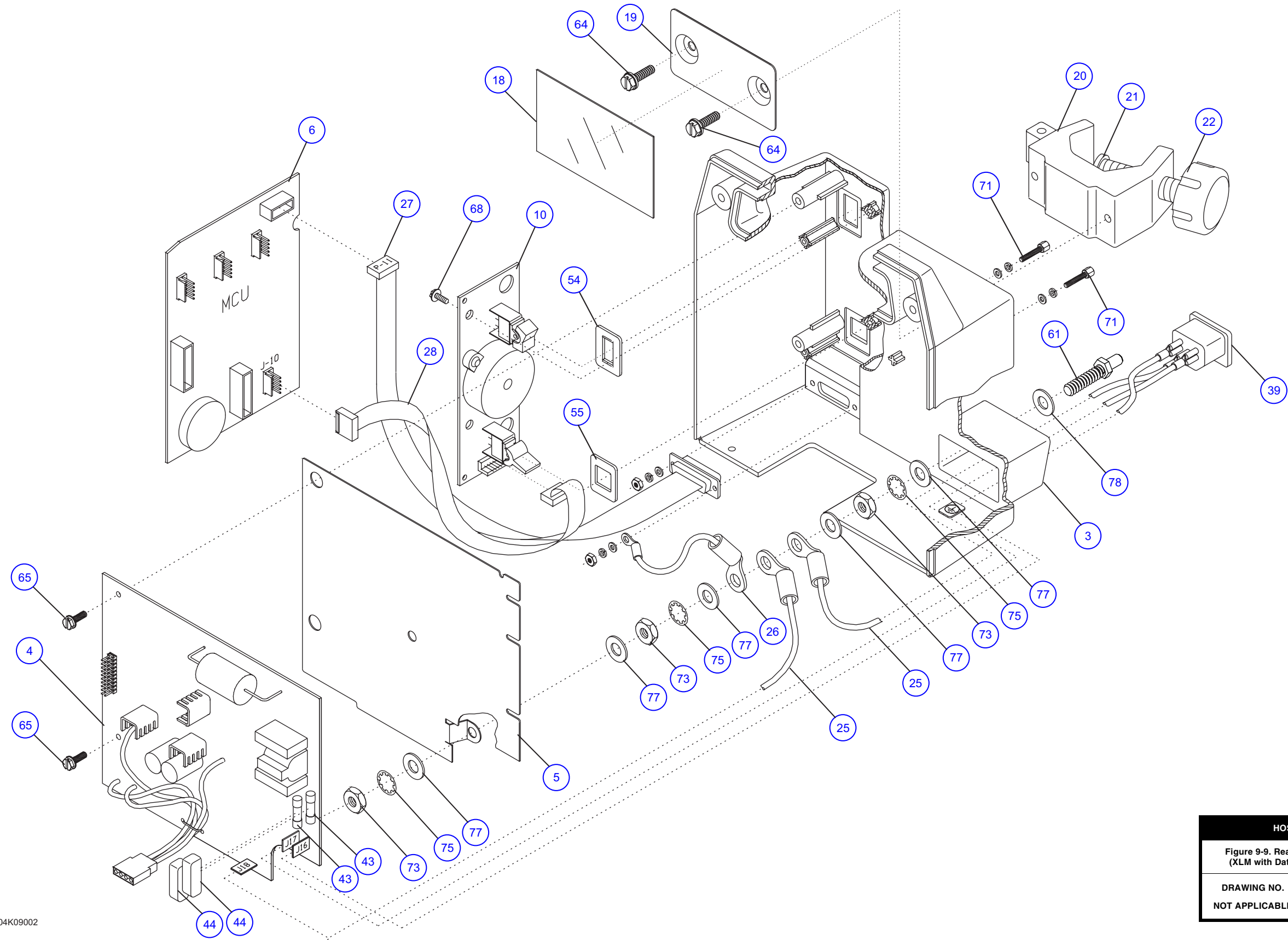

04K09002

| | |
|--|--------------------------|
| HOSPIRA, INC. | |
| Figure 9-9. Rear Enclosure Assembly (XLM with DataPort - International) | |
| DRAWING NO. NOT APPLICABLE | Rev. N/A Sheet 1 of 1 |

This page intentionally left blank.

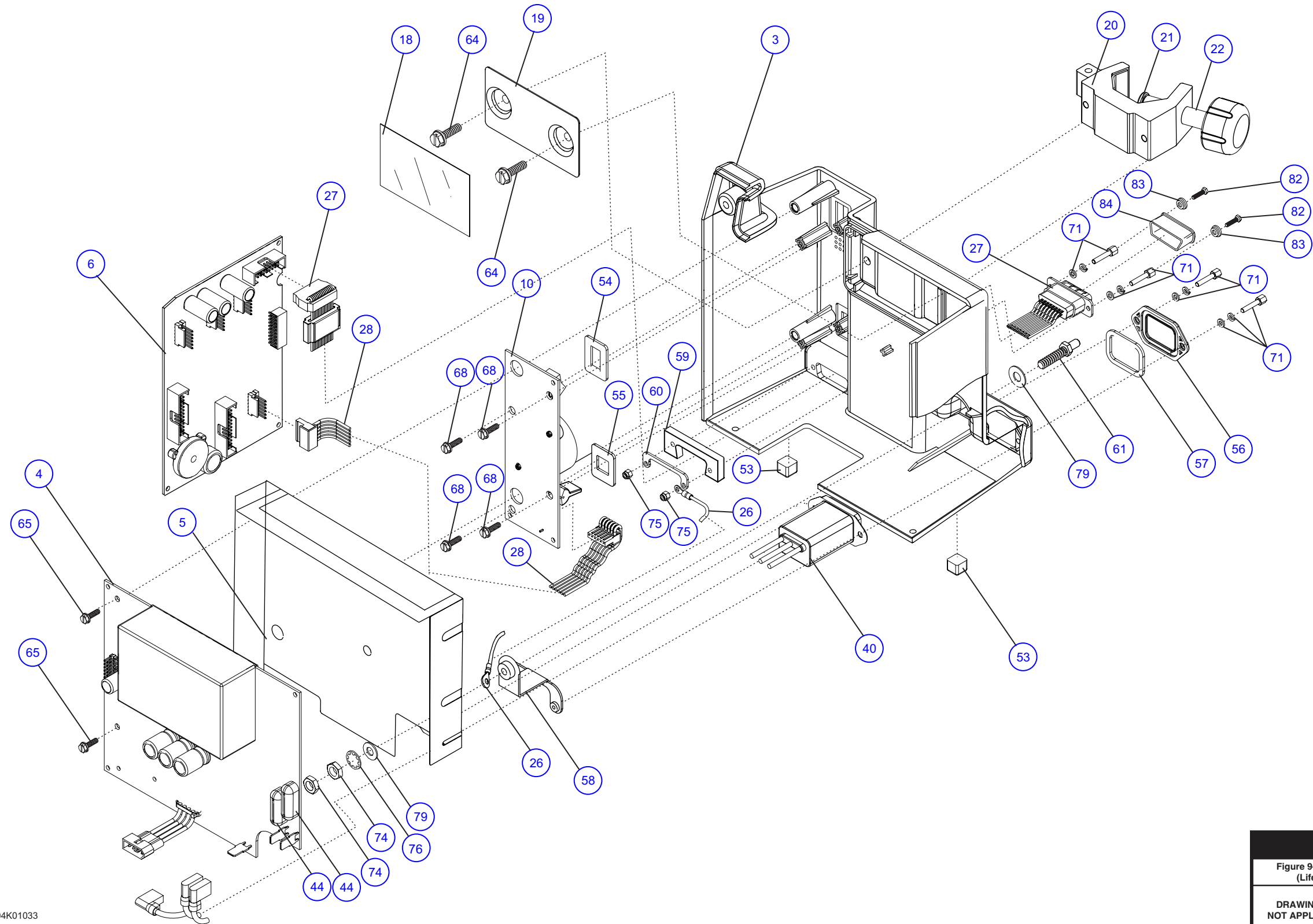

04K01033

| | |
|--|--------------------------|
| HOSPIRA, INC. | |
| Figure 9-10. Rear Enclosure Assembly (LifeCare XLM with DataPort) | |
| DRAWING NO. NOT APPLICABLE | Rev. N/A Sheet 1 of 1 |

This page intentionally left blank.

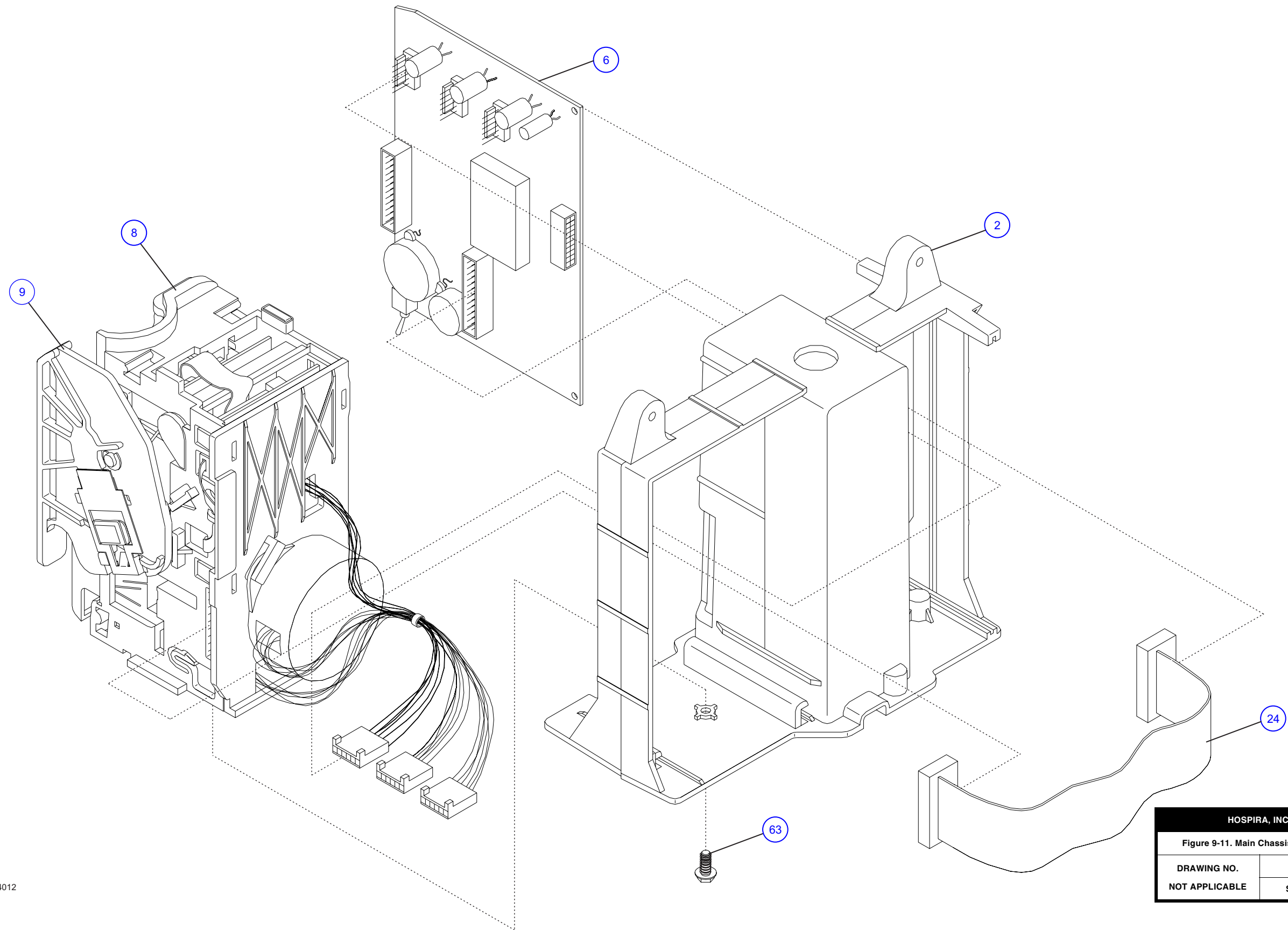

04K04012

| | |
|------------------------------------|--------------|
| HOSPIRA, INC. | |
| Figure 9-11. Main Chassis Assembly | |
| DRAWING NO. | Rev. N/A |
| NOT APPLICABLE | Sheet 1 of 1 |

This page intentionally left blank.

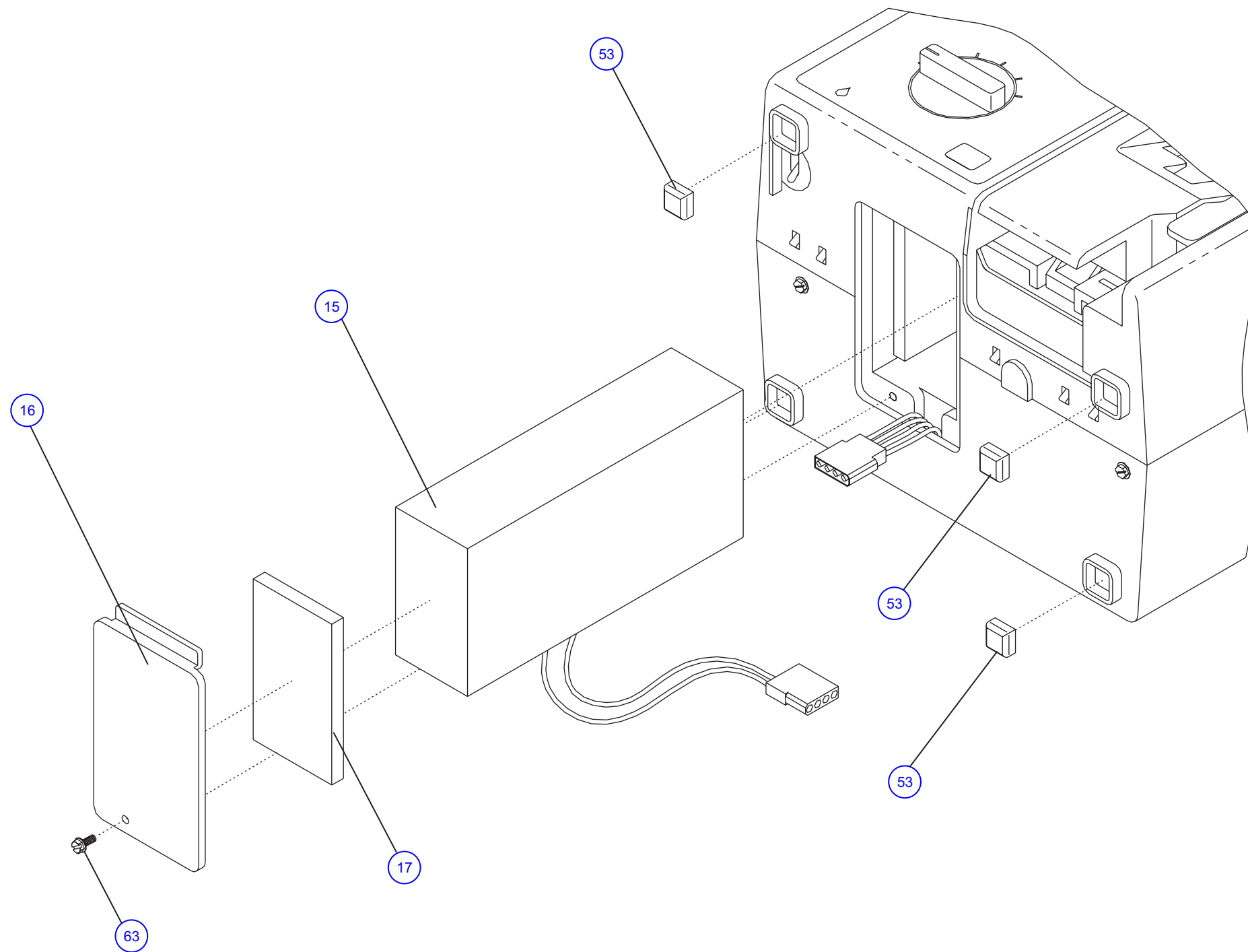

04K04025

| | |
|----------------------------------|--------------|
| HOSPIRA, INC. | |
| Figure 9-12. Battery Replacement | |
| DRAWING NO. | Rev. N/A |
| NOT APPLICABLE | Sheet 1 of 1 |

This page intentionally left blank.

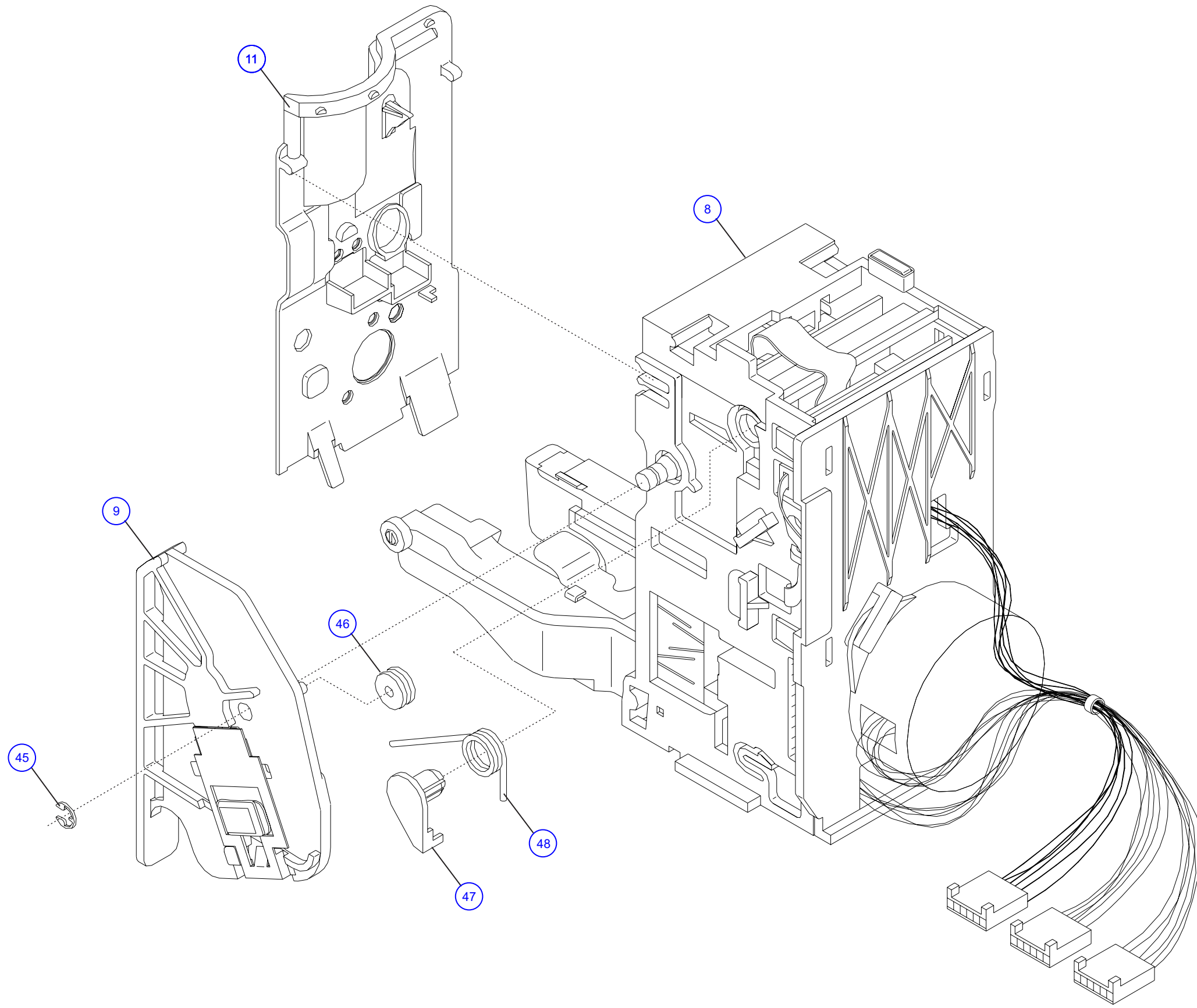

04K04013

| | |
|----------------------------------|--------------|
| HOSPIRA, INC. | |
| Figure 9-13. Mechanical Assembly | |
| DRAWING NO. | Rev. N/A |
| NOT APPLICABLE | Sheet 1 of 2 |

This page intentionally left blank.

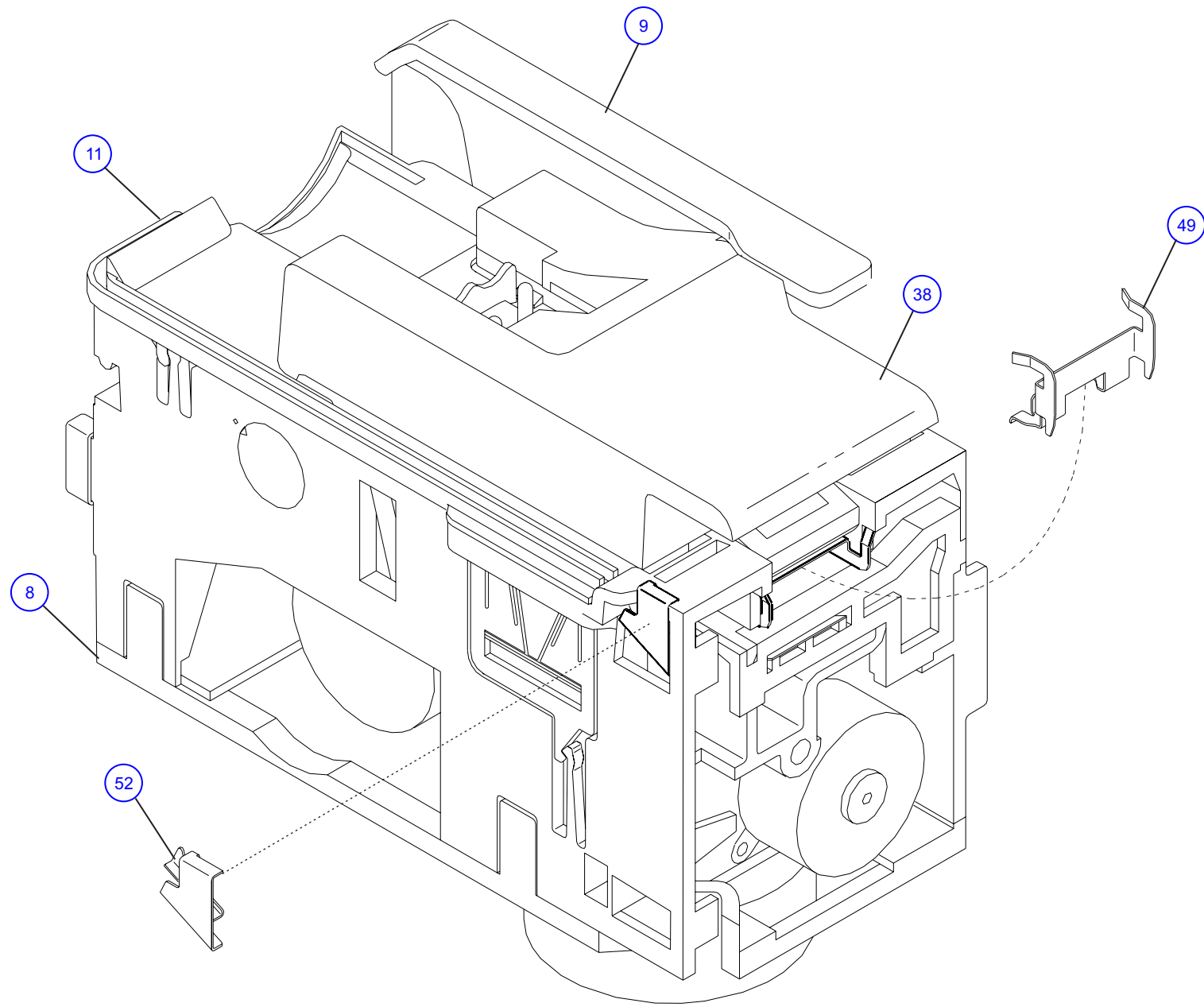

04K04014

| | |
|----------------------------------|--------------|
| HOSPIRA, INC. | |
| Figure 9-13. Mechanical Assembly | |
| DRAWING NO. | Rev. N/A |
| NOT APPLICABLE | Sheet 2 of 2 |

This page intentionally left blank.

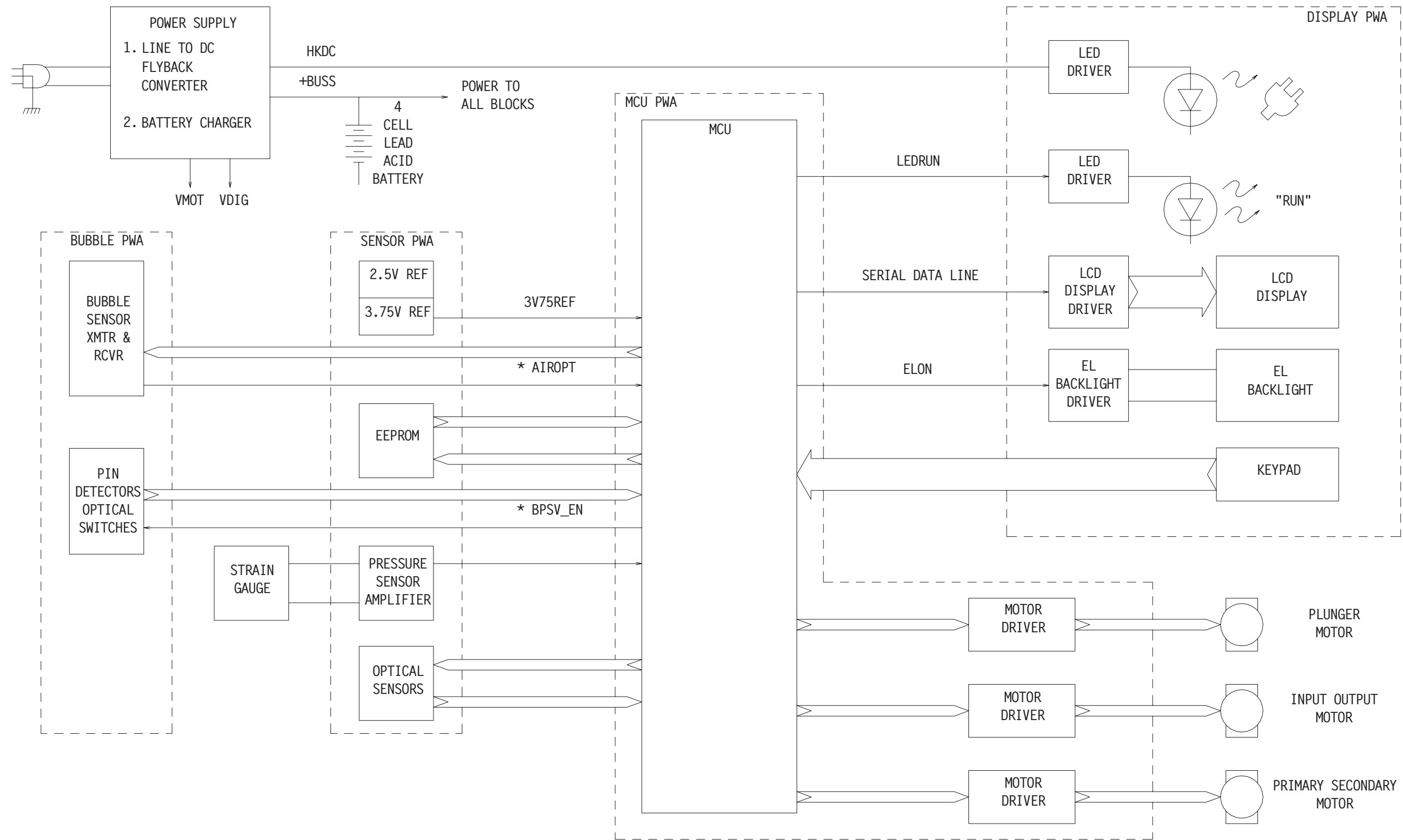

HOSPIRA, INC.

Figure 9-14. Plum XL Block Diagram

| | |
|--------------------|--------------|
| DRAWING NO. | Rev. N/A |
| NOT APPLICABLE | Sheet 1 of 1 |

94E06009

This page intentionally left blank.

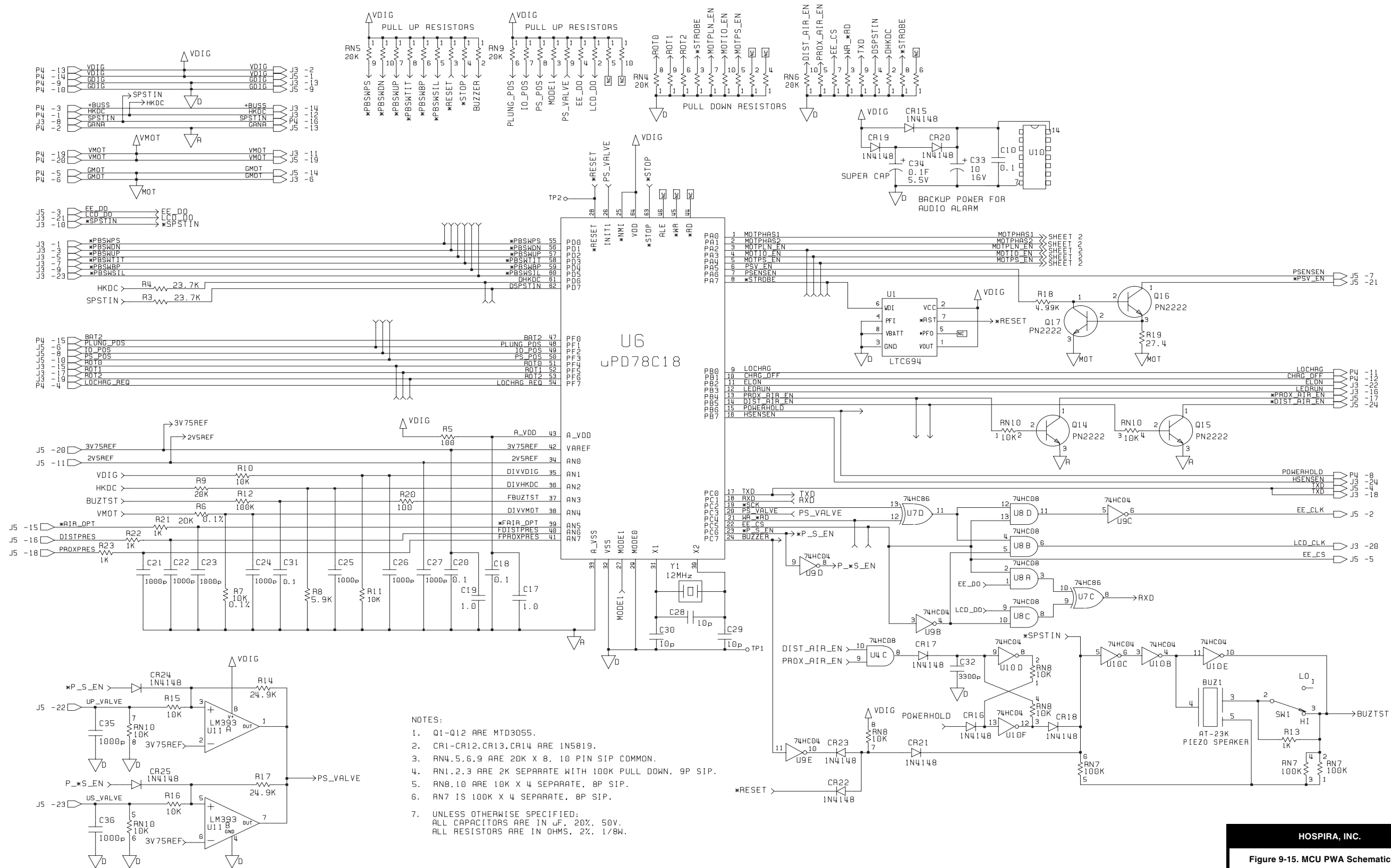

HOSPIRA, INC.

Figure 9-15. MCU PWA Schematic (XL)

| | |
|--------------------|---------------|
| DRAWING NO. | Rev. F |
| 249-00530-009 | Sheet 1 of 2 |

This page intentionally left blank.

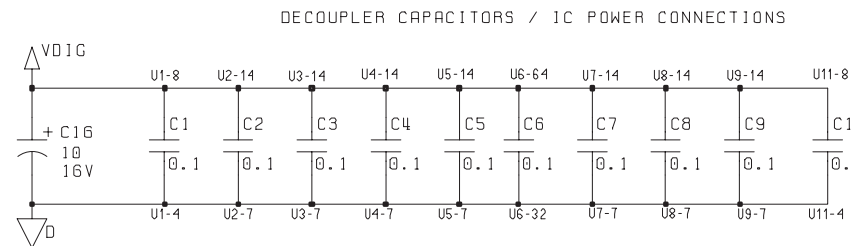
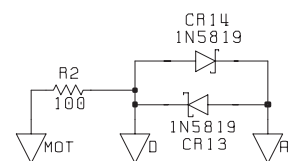
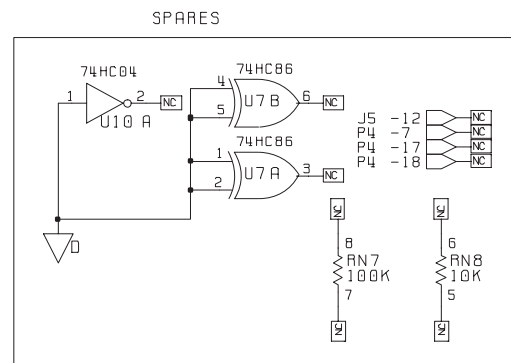
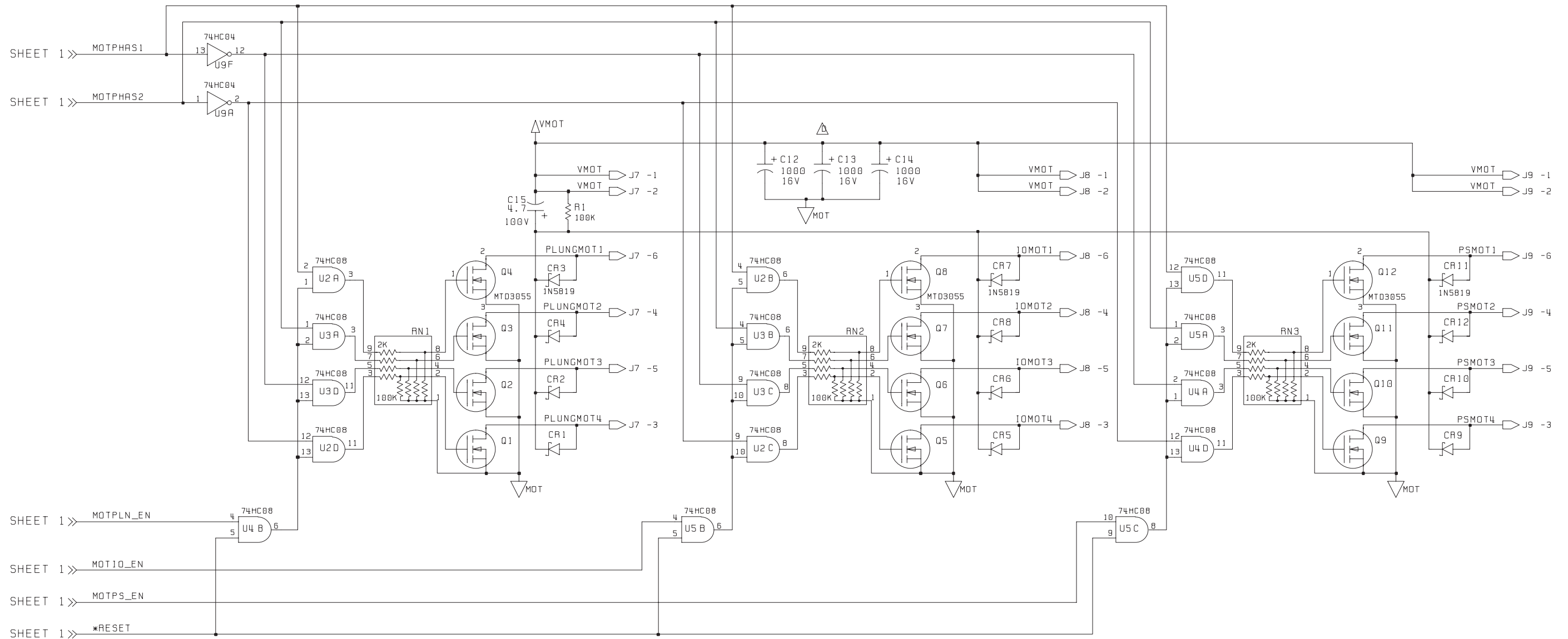

| | |
|--|---------------------|
| HOSPIRA, INC. | |
| Figure 9-15. MCU PWA Schematic (XL) | |
| DRAWING NO. | Rev. F |
| 249-00530-009 | Sheet 2 of 2 |

This page intentionally left blank.

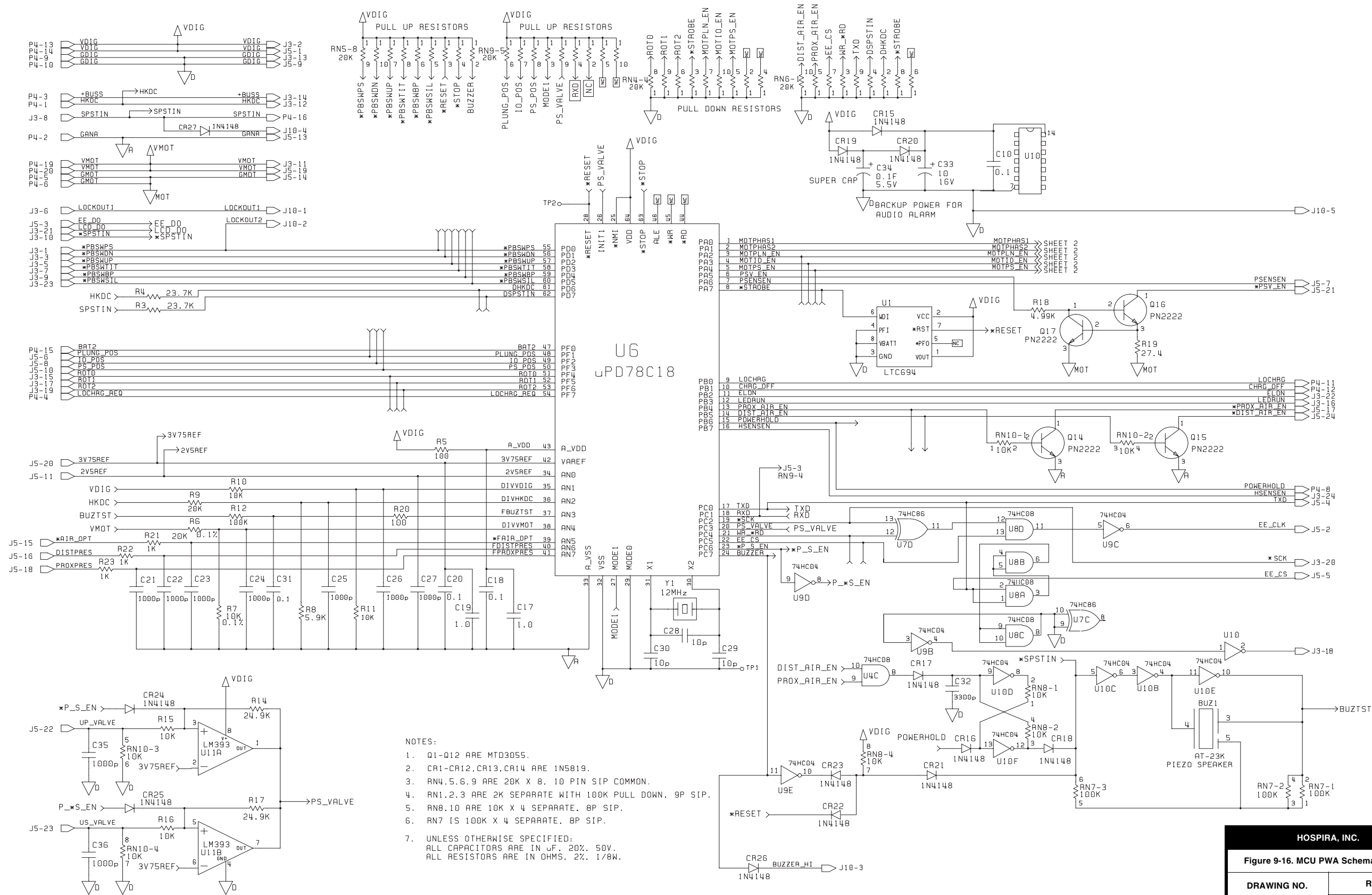

HOSPIRA, INC.

Figure 9-16. MCU PWA Schematic (XLM)

| | |
|--------------------|---------------|
| DRAWING NO. | Rev. D |
| 249-05907-002 | Sheet 1 of 2 |

This page intentionally left blank.

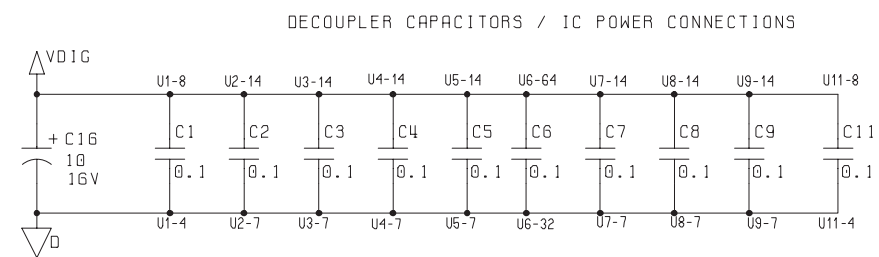
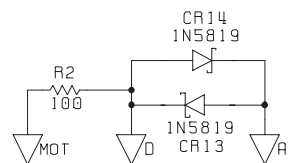
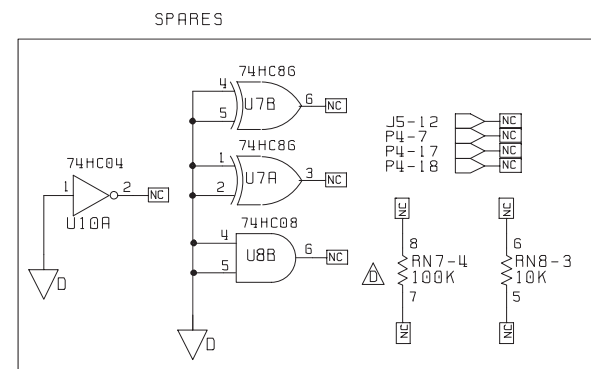
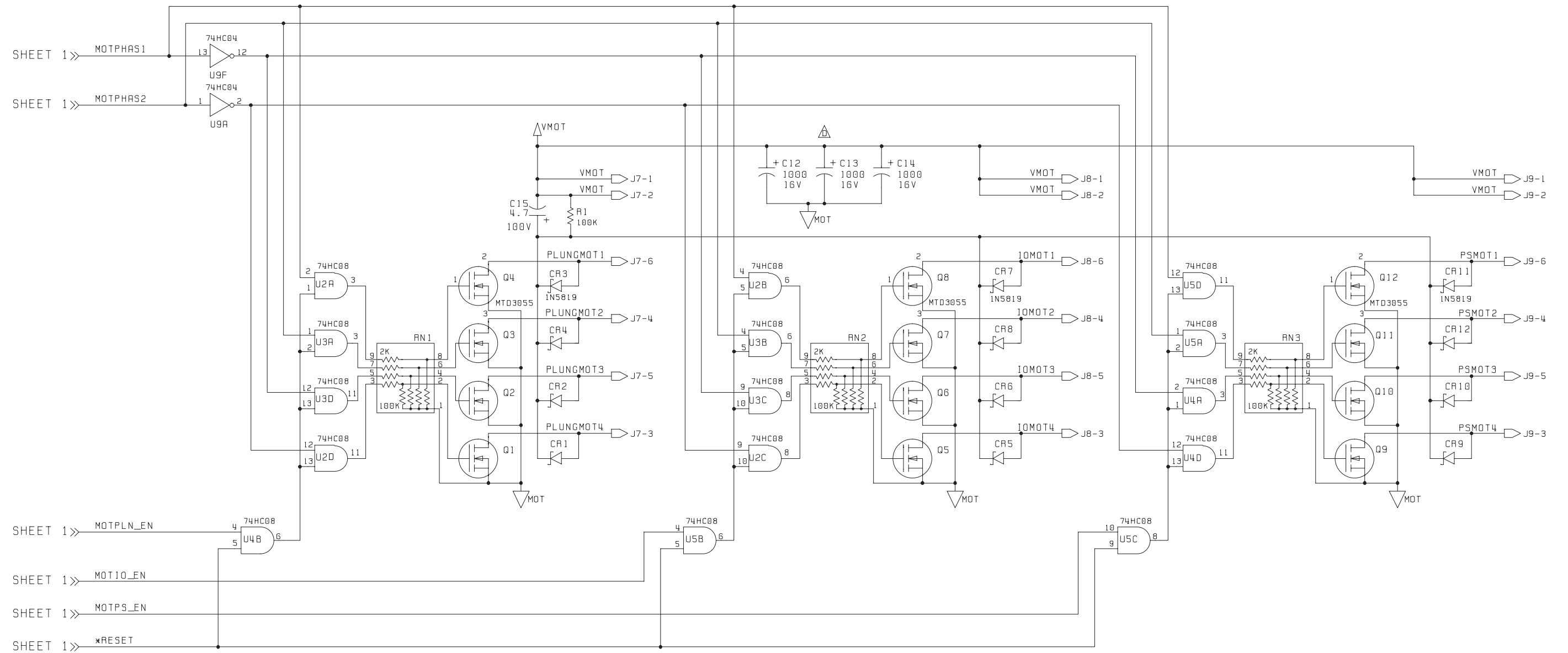

| | |
|--------------------------------------|--------------|
| HOSPIRA, INC. | |
| Figure 9-16. MCU PWA Schematic (XLM) | |
| DRAWING NO. | Rev. D |
| 249-05907-002 | Sheet 2 of 2 |

This page intentionally left blank.

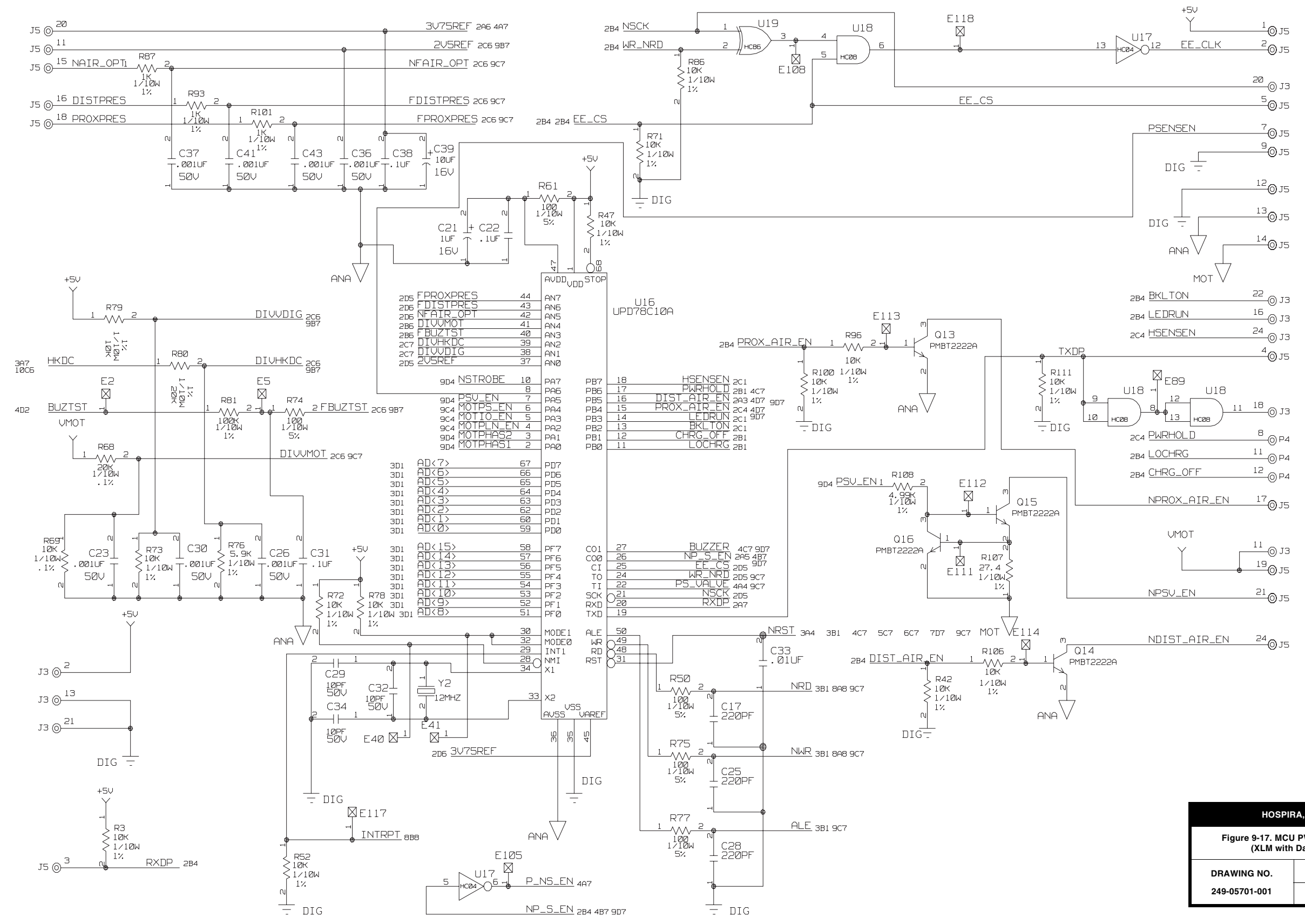

HOSPIRA, INC.

Figure 9-17. MCU PWA Schematic (XLM with DataPort)

| | |
|-------------------------------------|--------------------------------|
| DRAWING NO. 249-05701-001 | Rev. C Sheet 1 of 18 |
|-------------------------------------|--------------------------------|

This page intentionally left blank.

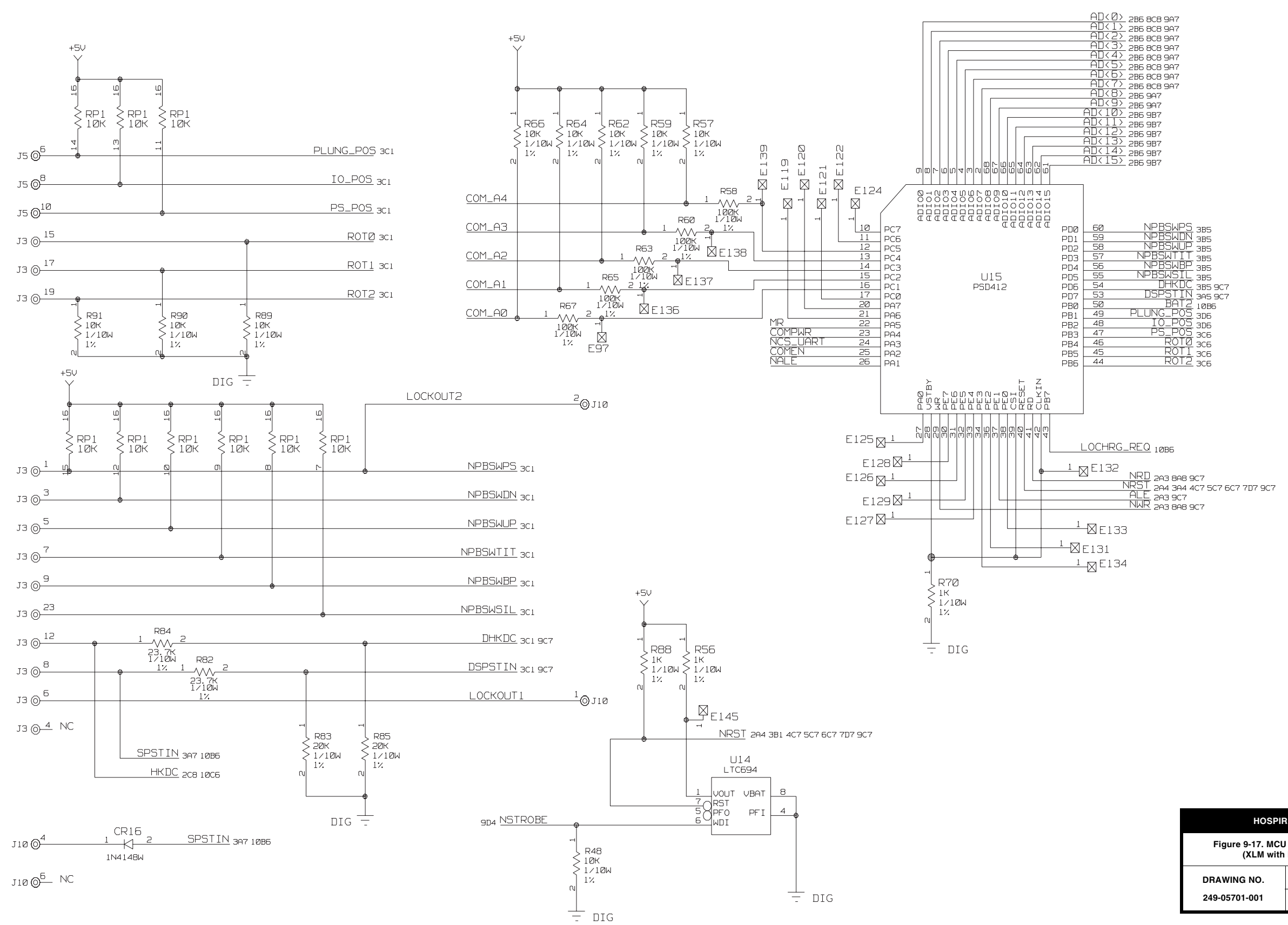

HOSPIRA, INC.
Figure 9-17. MCU PWA Schematic (XLM with DataPort)
 DRAWING NO. 249-05701-001 Rev. C
 Sheet 2 of 18

This page intentionally left blank.

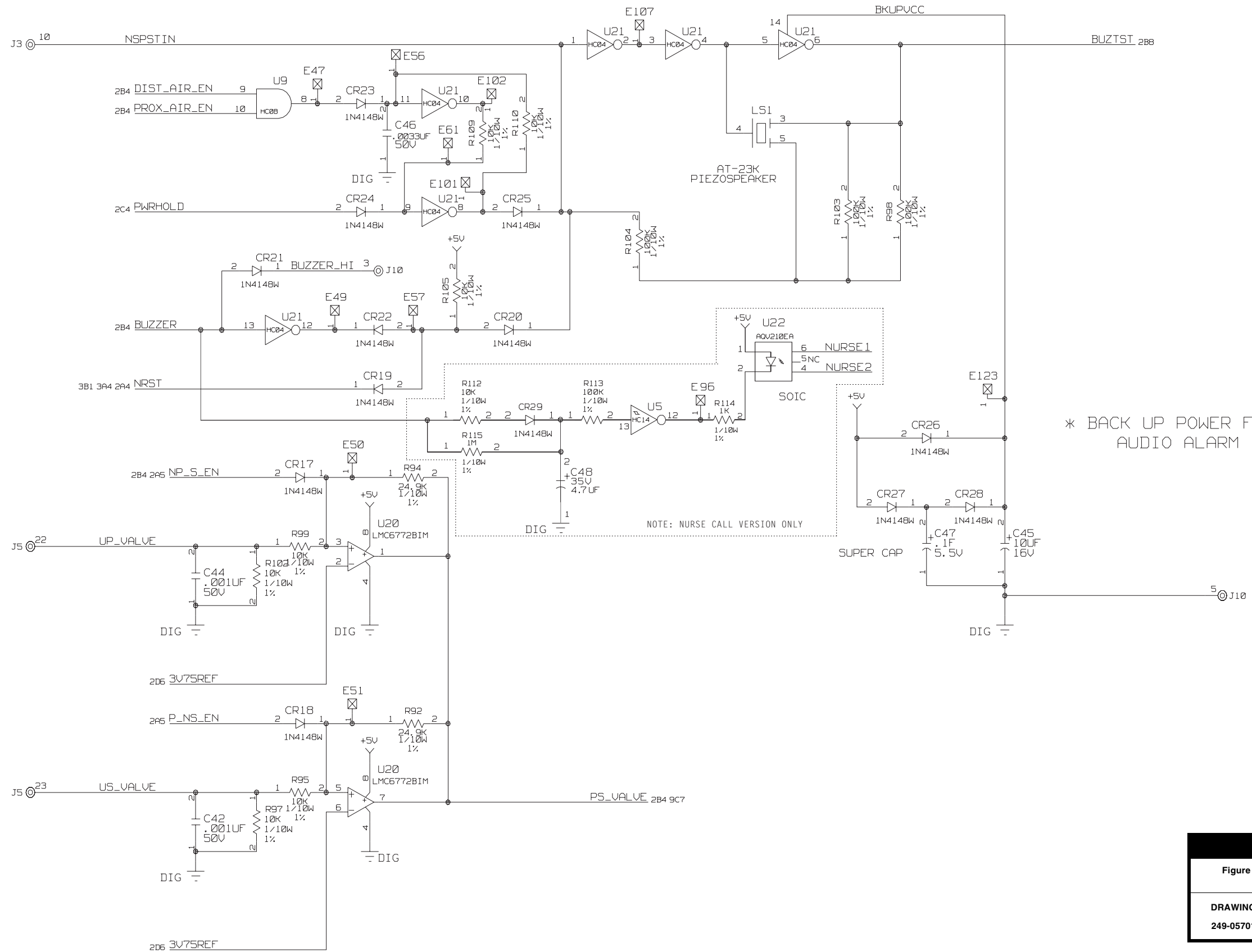

* BACK UP POWER FOR AUDIO ALARM

| | |
|--|-------------------------|
| HOSPIRA, INC. | |
| Figure 9-17. MCU PWA Schematic (XLM with DataPort) | |
| DRAWING NO. 249-05701-001 | Rev. C Sheet 3 of 18 |

This page intentionally left blank.

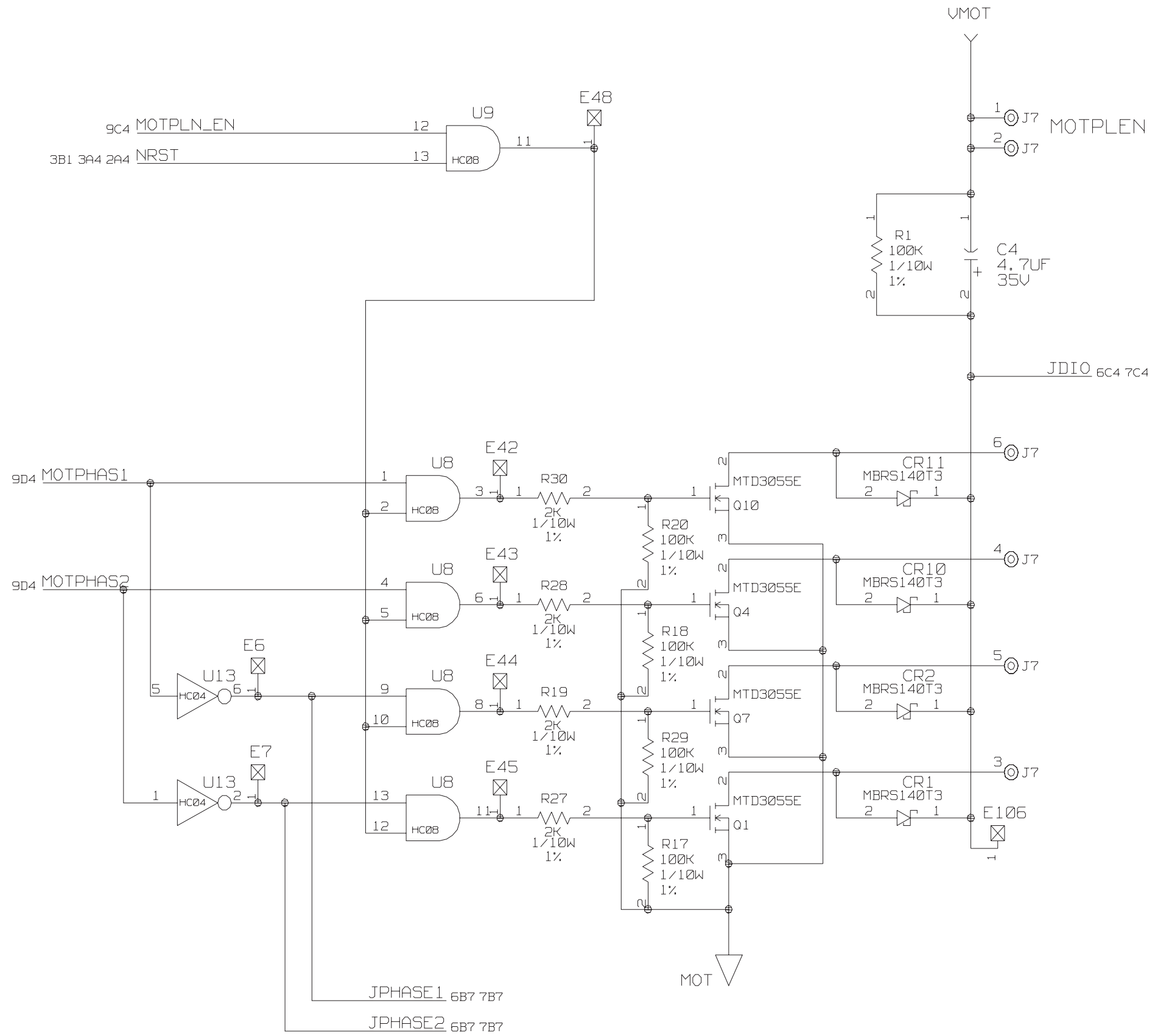

HOSPIRA

Figure 9-17. MCU PWA Schematic (XLM with DataPort)

| | |
|-------------------------------------|--------------------------------|
| DRAWING NO. 249-05701-001 | Rev. C Sheet 4 of 18 |
|-------------------------------------|--------------------------------|

This page intentionally left blank.

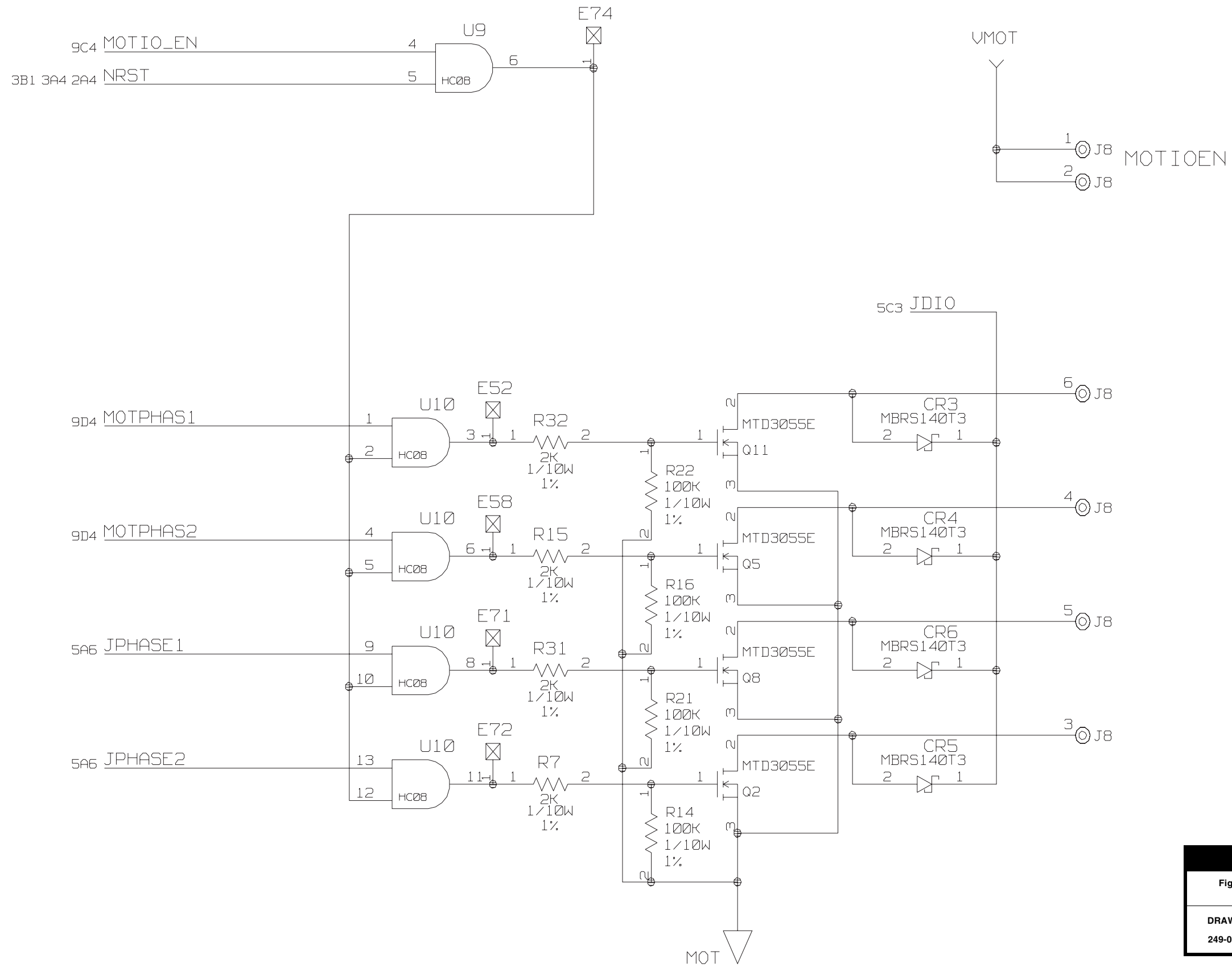

HOSPIRA, INC.
 Figure 9-17. MCU PWA Schematic (XLM with DataPort)
 DRAWING NO. 249-05701-001
 Rev. C
 Sheet 5 of 18

This page intentionally left blank.

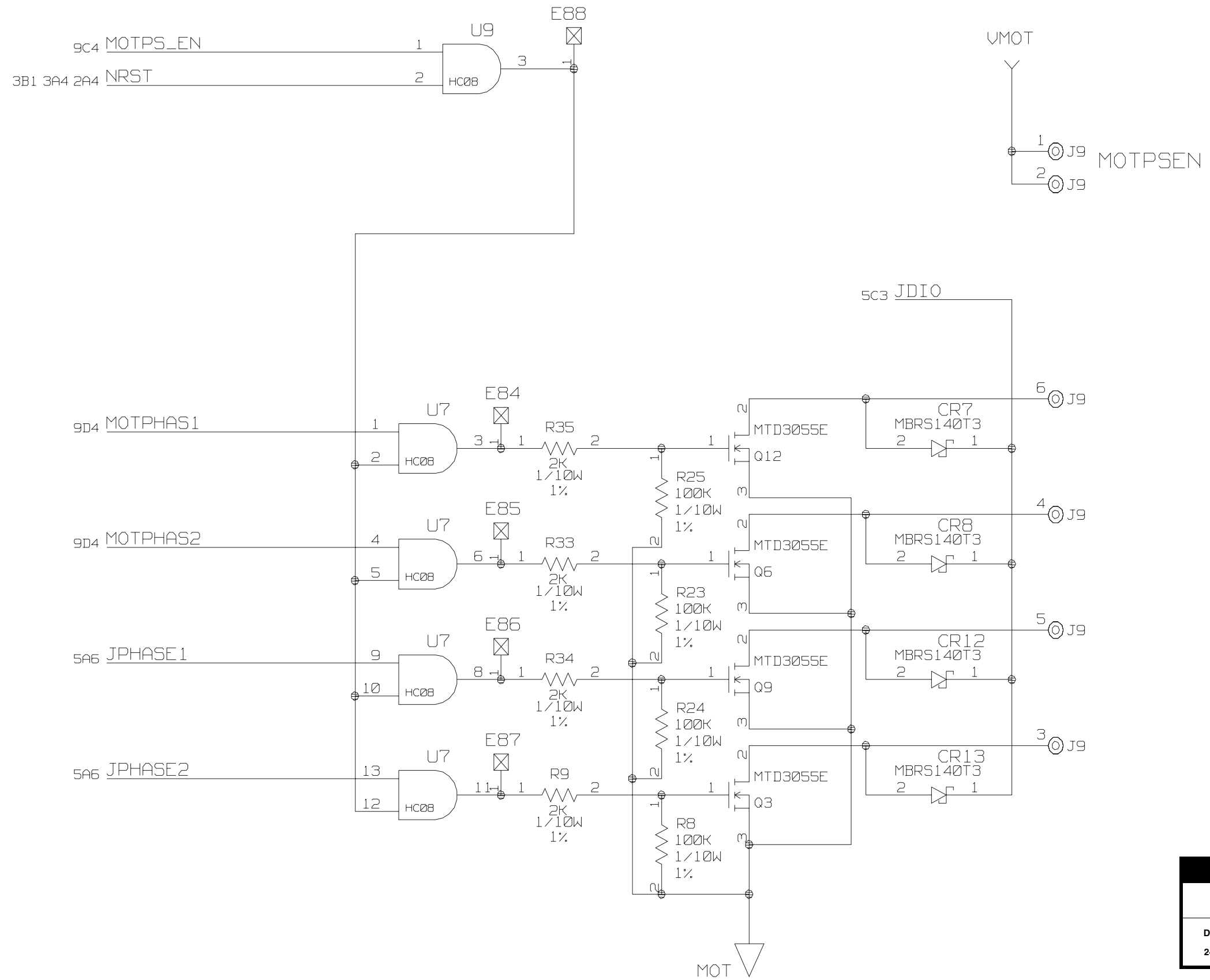

HOSPIRA, INC.
Figure 9-17. MCU PWA Schematic (XLM with DataPort)
 DRAWING NO. 249-05701-001 Rev. C
 Sheet 6 of 18

This page intentionally left blank.

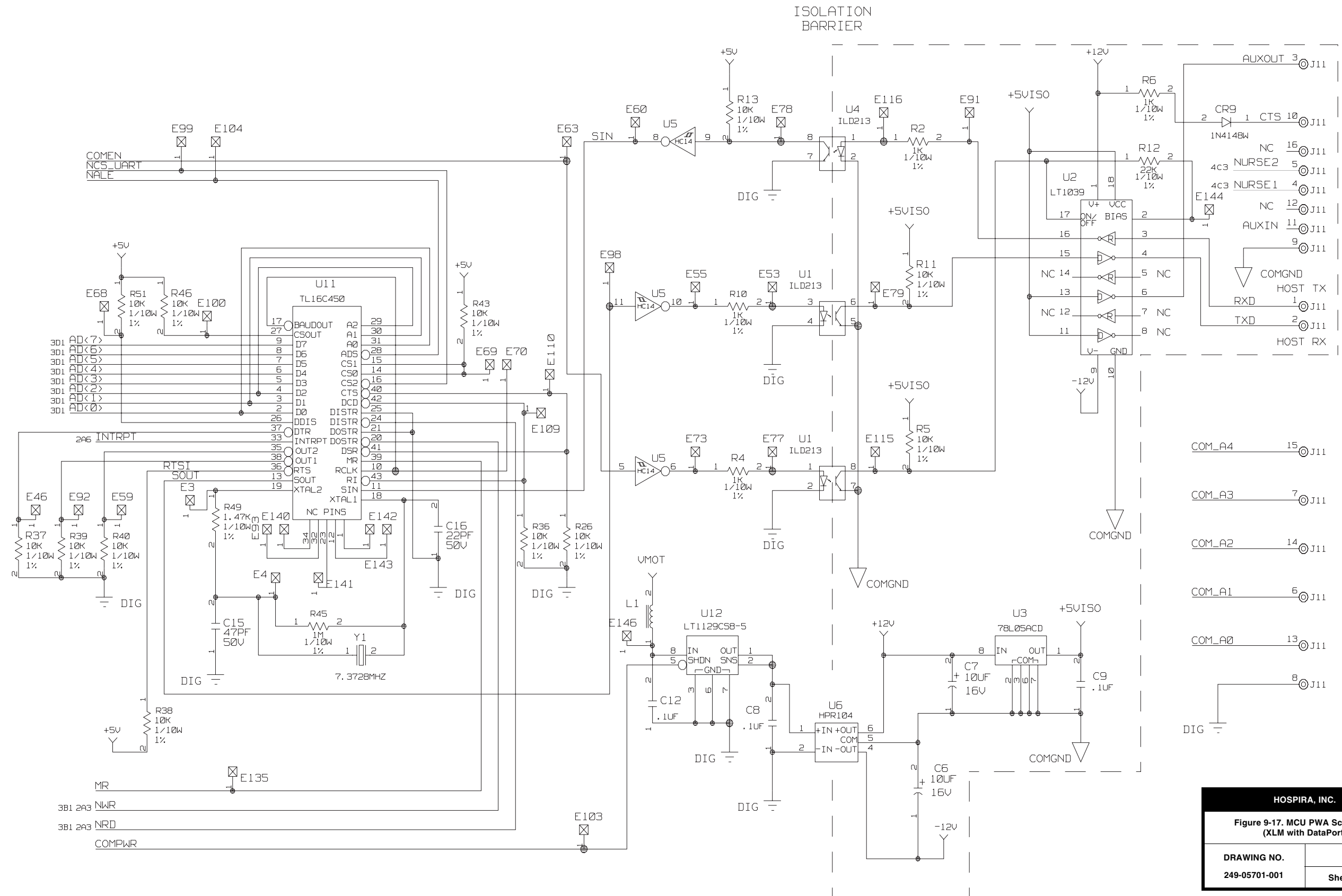

HOSPIRA, INC.
Figure 9-17. MCU PWA Schematic (XLM with DataPort)
 DRAWING NO. 249-05701-001 Rev. C
 Sheet 7 of 18

This page intentionally left blank.

PROBE PADS

| | | | | |
|-------------|-------------|---|---|-----|
| 2B4 | DIST_AIR_EN | 1 | ⊗ | E65 |
| 2B4 | PROX_AIR_EN | 1 | ⊗ | E66 |
| 2B4 | BUZZER | 1 | ⊗ | E1 |
| 2B4 2A5 | NP_S_EN | 1 | ⊗ | E17 |
| 2B4 | WR_NRD | 1 | ⊗ | E75 |
| 4A4 2B4 | PS_VALVE | 1 | ⊗ | E76 |
| 3B1 2A3 | ALE | 1 | ⊗ | E62 |
| 3B1 2A3 | NWR | 1 | ⊗ | E81 |
| 3B1 2A3 | NRD | 1 | ⊗ | E82 |
| 3B1 3A4 2A4 | NRST | 1 | ⊗ | E83 |
| 3C1 3A5 | DSPSTIN | 1 | ⊗ | E64 |
| 3C1 3B5 | DHKDC | 1 | ⊗ | E67 |
| 2D5 | FPROXPRES | 1 | ⊗ | E8 |
| 2D6 | FDISTPRES | 1 | ⊗ | E9 |
| 2D6 | NFAIR_OPT | 1 | ⊗ | E10 |
| 2B6 | DIUVMOT | 1 | ⊗ | E11 |
| 2B6 | FBUZTST | 1 | ⊗ | E12 |
| 2C7 | DIUHKDC | 1 | ⊗ | E13 |
| 2C7 | DIUVDIG | 1 | ⊗ | E14 |
| 2D5 | 2V5REF | 1 | ⊗ | E15 |

| | | | | |
|-----|--------|---|---|-----|
| 3D1 | AD<15> | 1 | ⊗ | E24 |
| 3D1 | AD<14> | 1 | ⊗ | E25 |
| 3D1 | AD<13> | 1 | ⊗ | E26 |
| 3D1 | AD<12> | 1 | ⊗ | E27 |
| 3D1 | AD<11> | 1 | ⊗ | E28 |
| 3D1 | AD<10> | 1 | ⊗ | E29 |
| 3D1 | AD<9> | 1 | ⊗ | E30 |
| 3D1 | AD<8> | 1 | ⊗ | E31 |
| 3D1 | AD<7> | 1 | ⊗ | E32 |
| 3D1 | AD<6> | 1 | ⊗ | E33 |
| 3D1 | AD<5> | 1 | ⊗ | E34 |
| 3D1 | AD<4> | 1 | ⊗ | E35 |
| 3D1 | AD<3> | 1 | ⊗ | E36 |
| 3D1 | AD<2> | 1 | ⊗ | E37 |
| 3D1 | AD<1> | 1 | ⊗ | E38 |
| 3D1 | AD<0> | 1 | ⊗ | E39 |

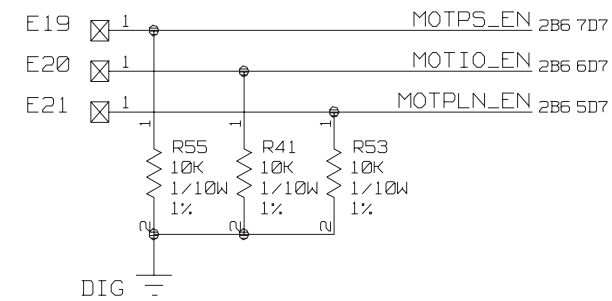
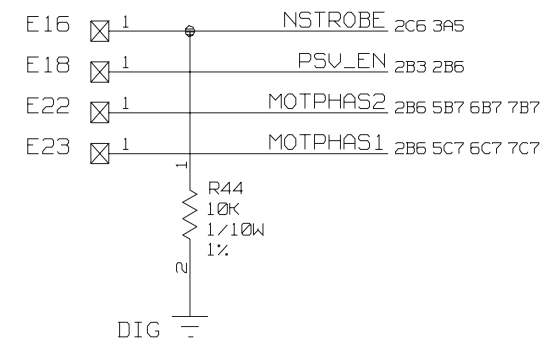

| HOSPIRA, INC. | |
|--|---------------|
| Figure 9-17. MCU PWA Schematic (XLM with DataPort) | |
| DRAWING NO. | Rev. C |
| 249-05701-001 | Sheet 8 of 18 |

This page intentionally left blank.

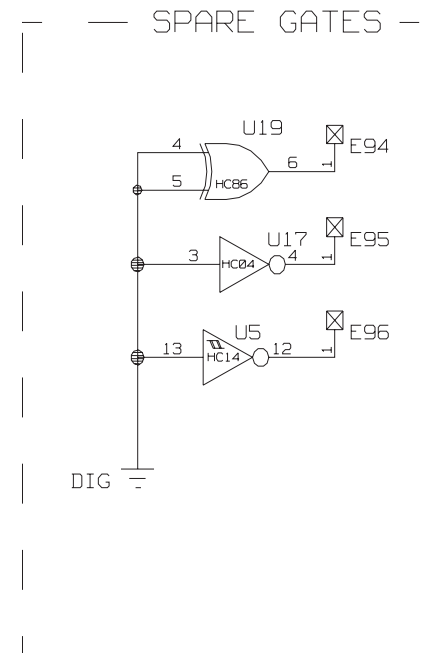
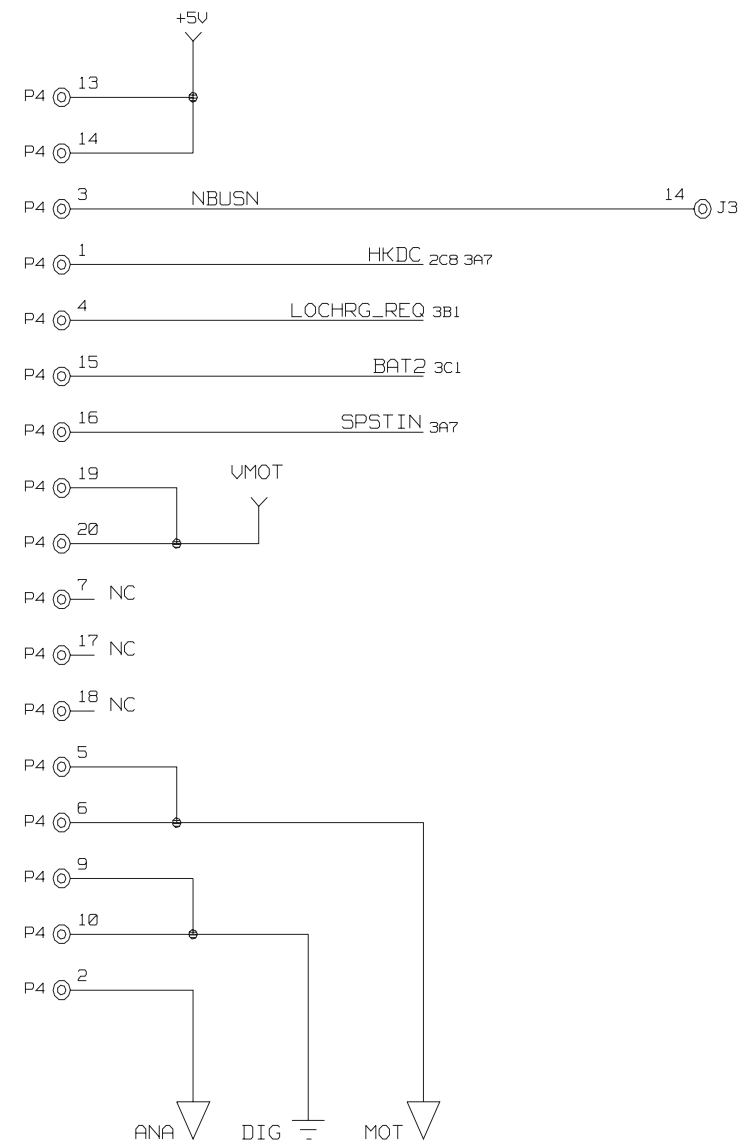
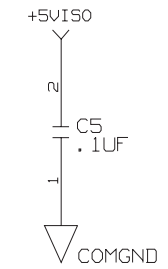
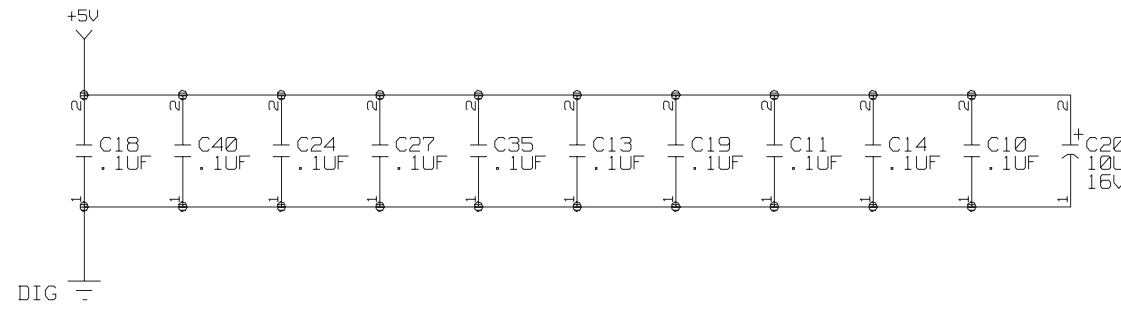
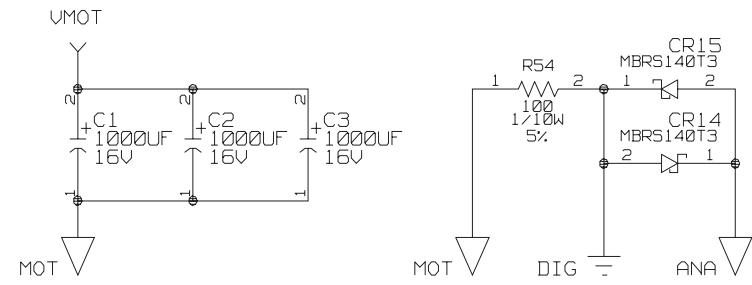

| HOSPIRA, INC. | |
|--|---------------|
| Figure 9-17. MCU PWA Schematic (XLM with DataPort) | |
| DRAWING NO. | Rev. C |
| 249-05701-001 | Sheet 9 of 18 |

This page intentionally left blank.

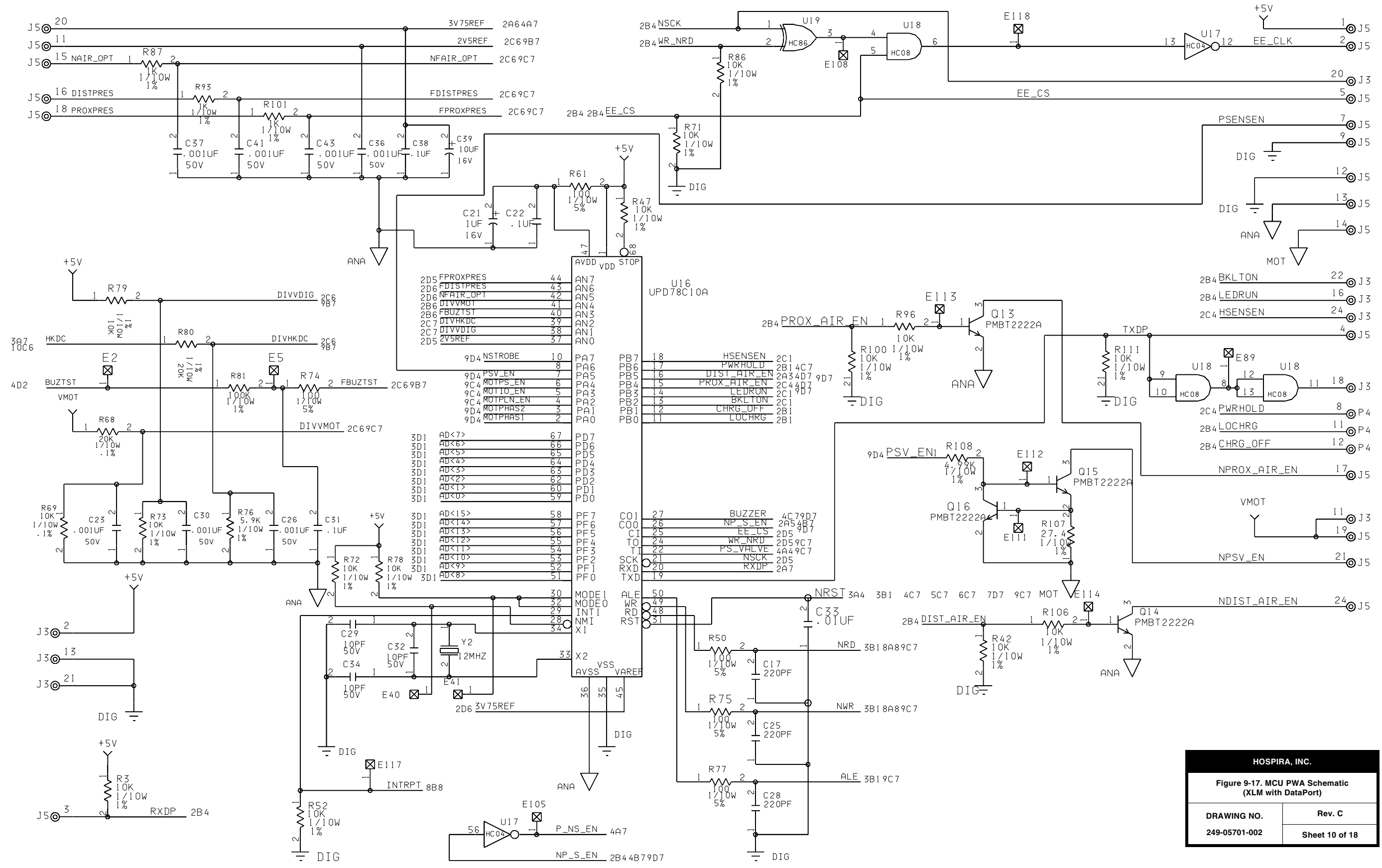

HOSPIRA, INC.
Figure 9-17. MCU PWA Schematic (XLM with DataPort)
 DRAWING NO. 249-05701-002 Rev. C
 Sheet 10 of 18

This page intentionally left blank.

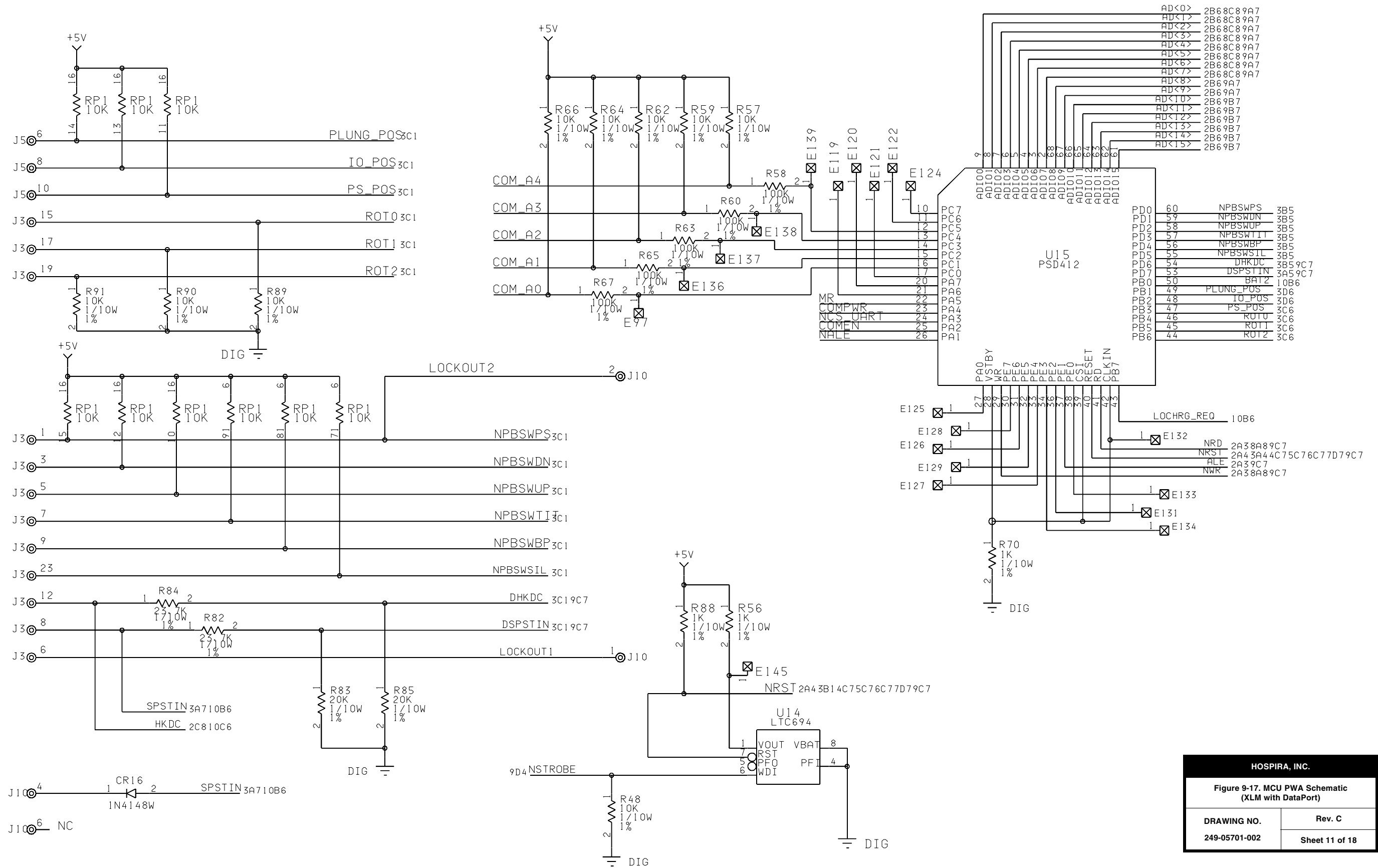

HOSPIRA, INC.
Figure 9-17. MCU PWA Schematic (XL M with DataPort)
 DRAWING NO. 249-05701-002 Rev. C
 Sheet 11 of 18

This page intentionally left blank.

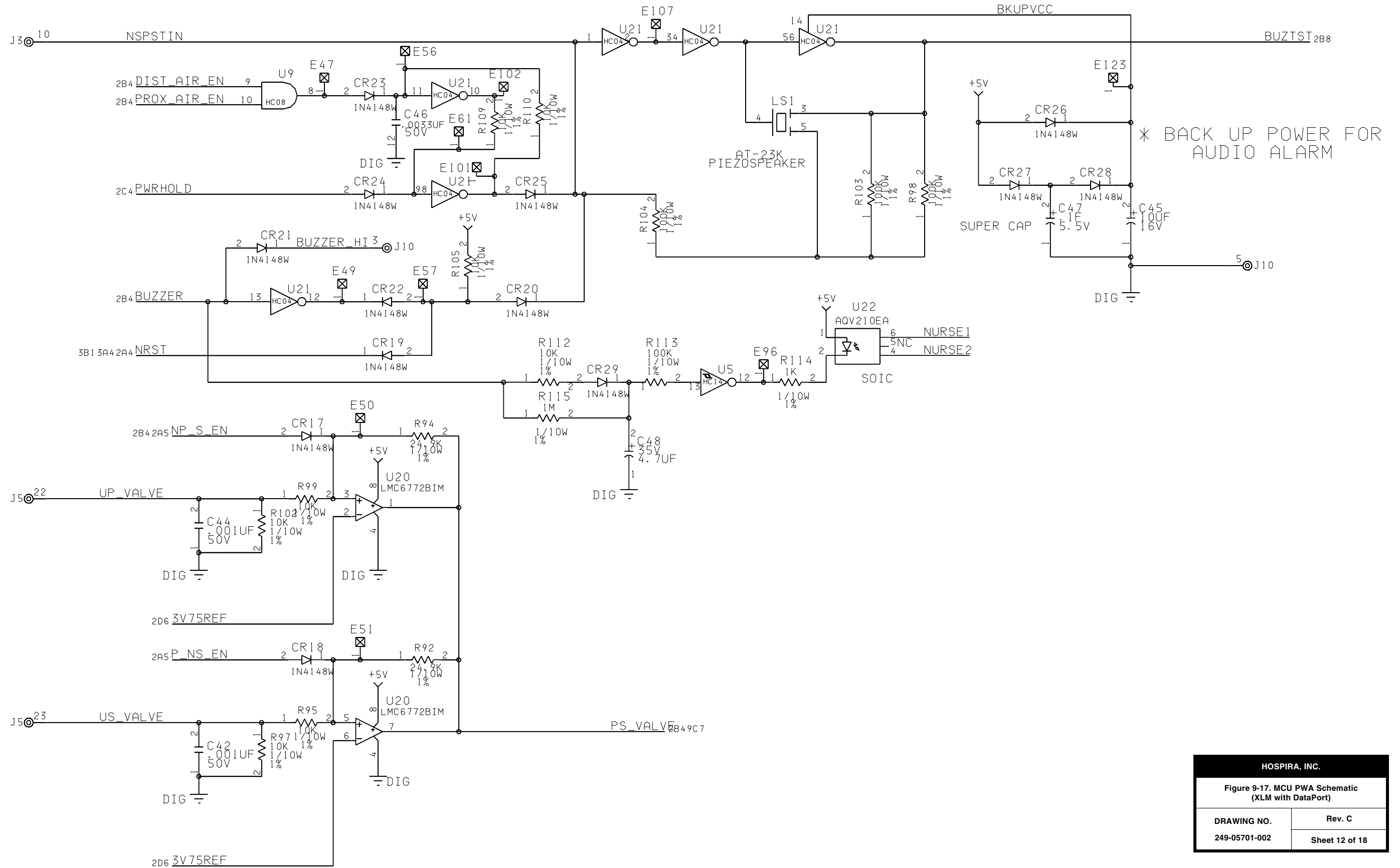

HOSPIRA, INC.
 Figure 9-17. MCU PWA Schematic (XLM with DataPort)

| | |
|---------------|----------------|
| DRAWING NO. | Rev. C |
| 249-05701-002 | Sheet 12 of 18 |

This page intentionally left blank.

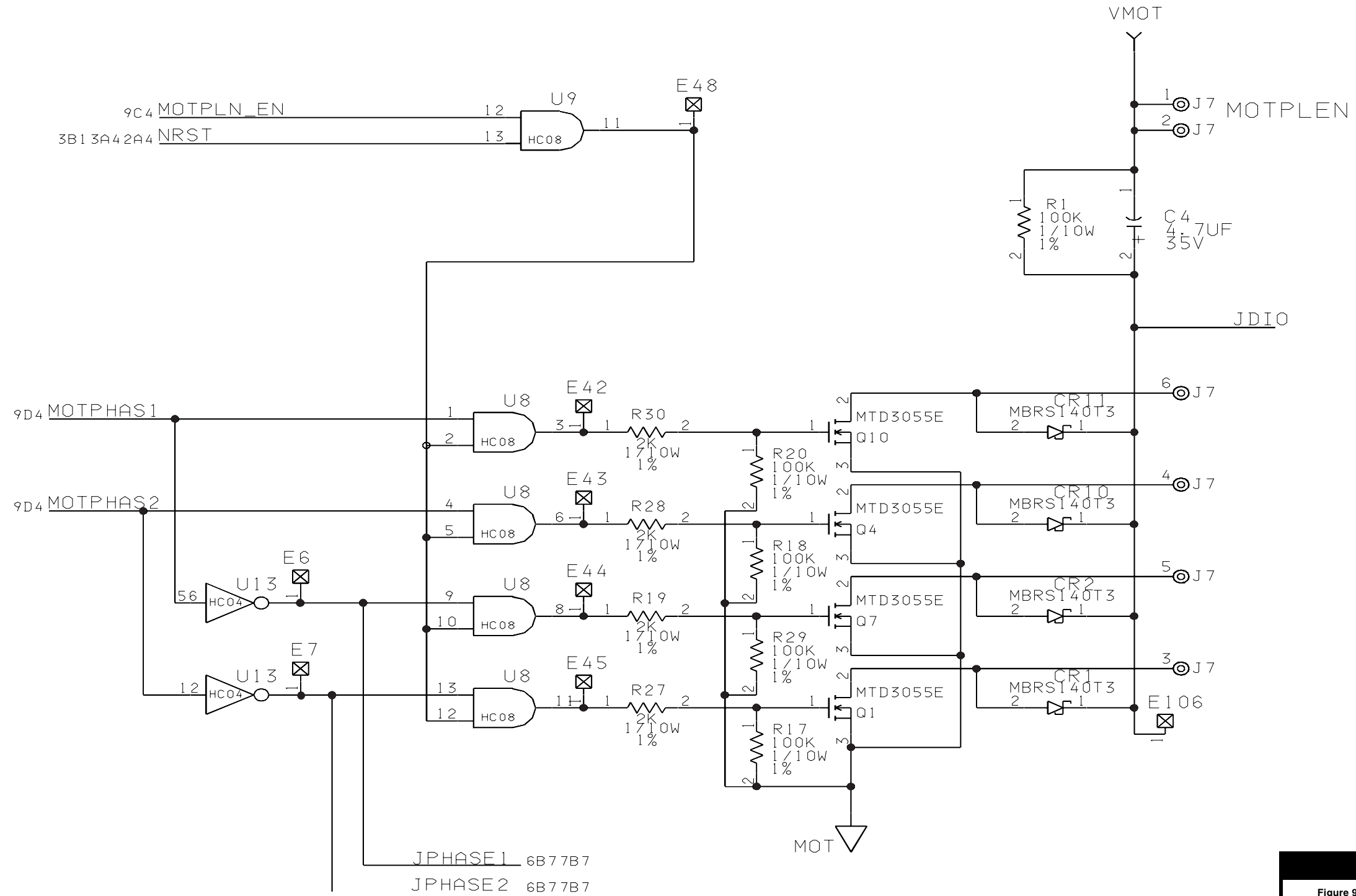

HOSPIRA, INC.
 Figure 9-17. MCU PWA Schematic (XLM with DataPort)

| | |
|---------------|----------------|
| DRAWING NO. | Rev. C |
| 249-05701-002 | Sheet 13 of 18 |

This page intentionally left blank.

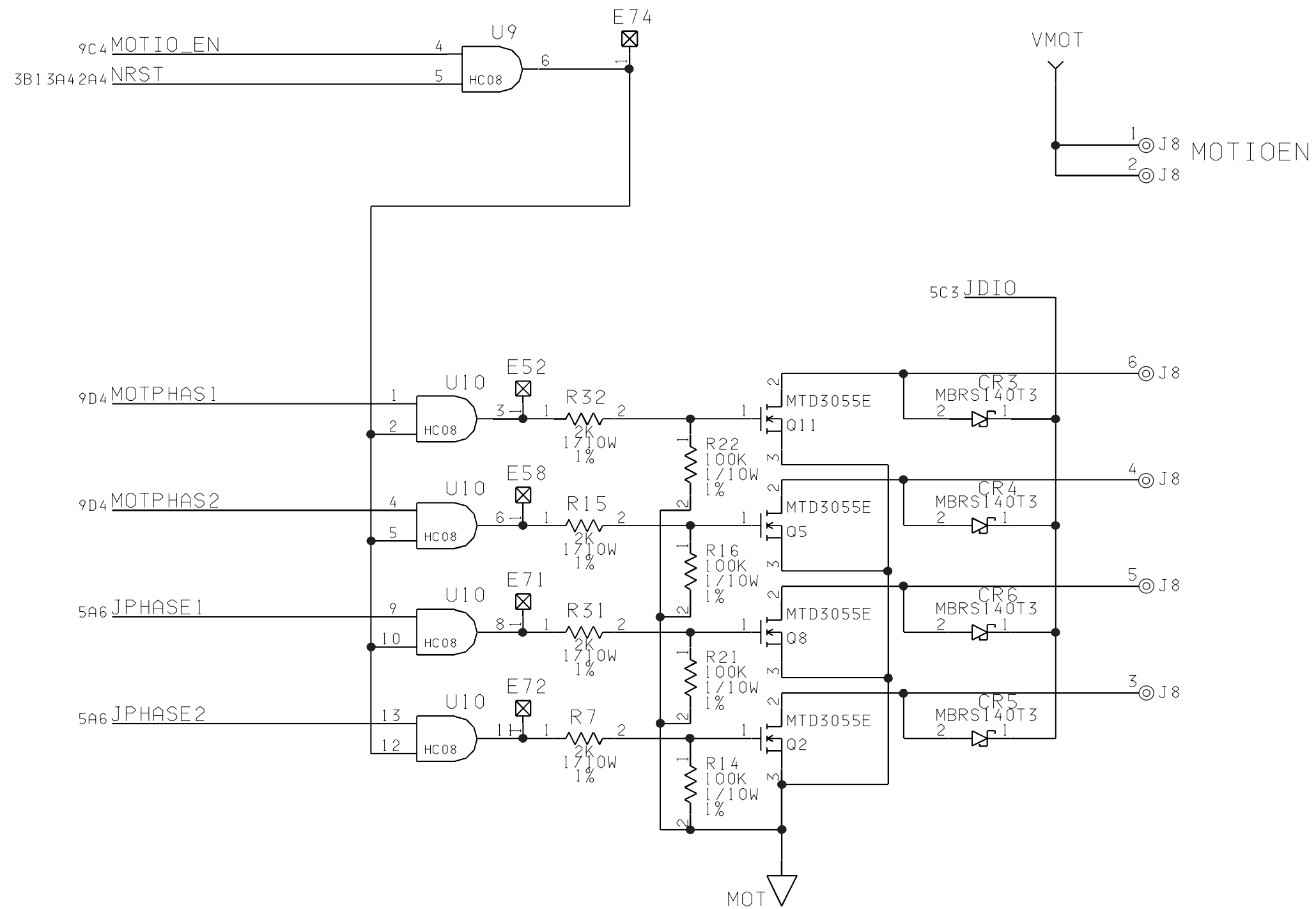

HOSPIRA, INC.
 Figure 9-17. MCU PWA Schematic (XLM with DataPort)

| | |
|---------------|----------------|
| DRAWING NO. | Rev. C |
| 249-05701-002 | Sheet 14 of 18 |

This page intentionally left blank.

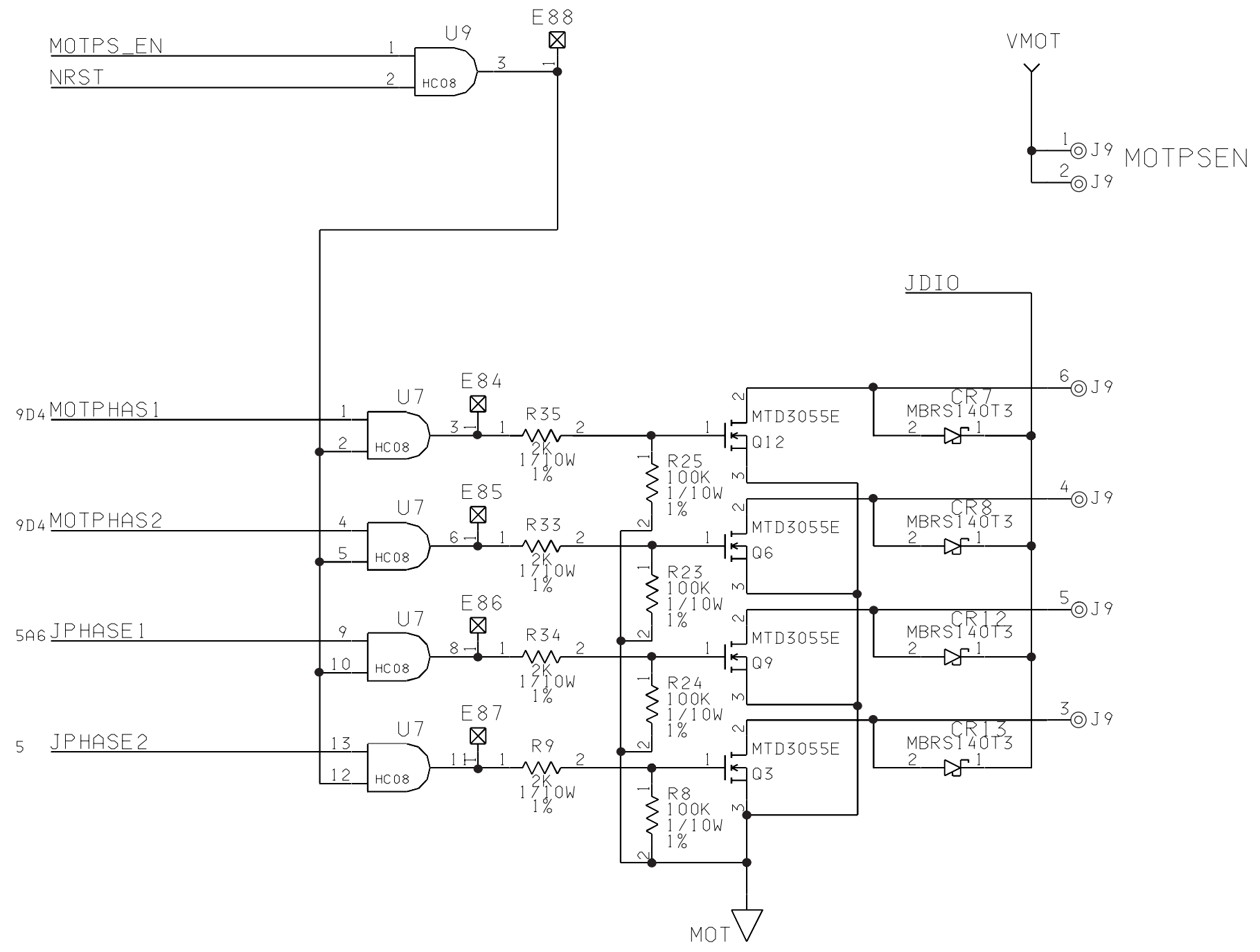

HOSPIRA, INC.
 Figure 9-17. MCU PWA Schematic (XLM with DataPort)
 DRAWING NO. 249-05701-002 Rev. C
 Sheet 15 of 18

This page intentionally left blank.

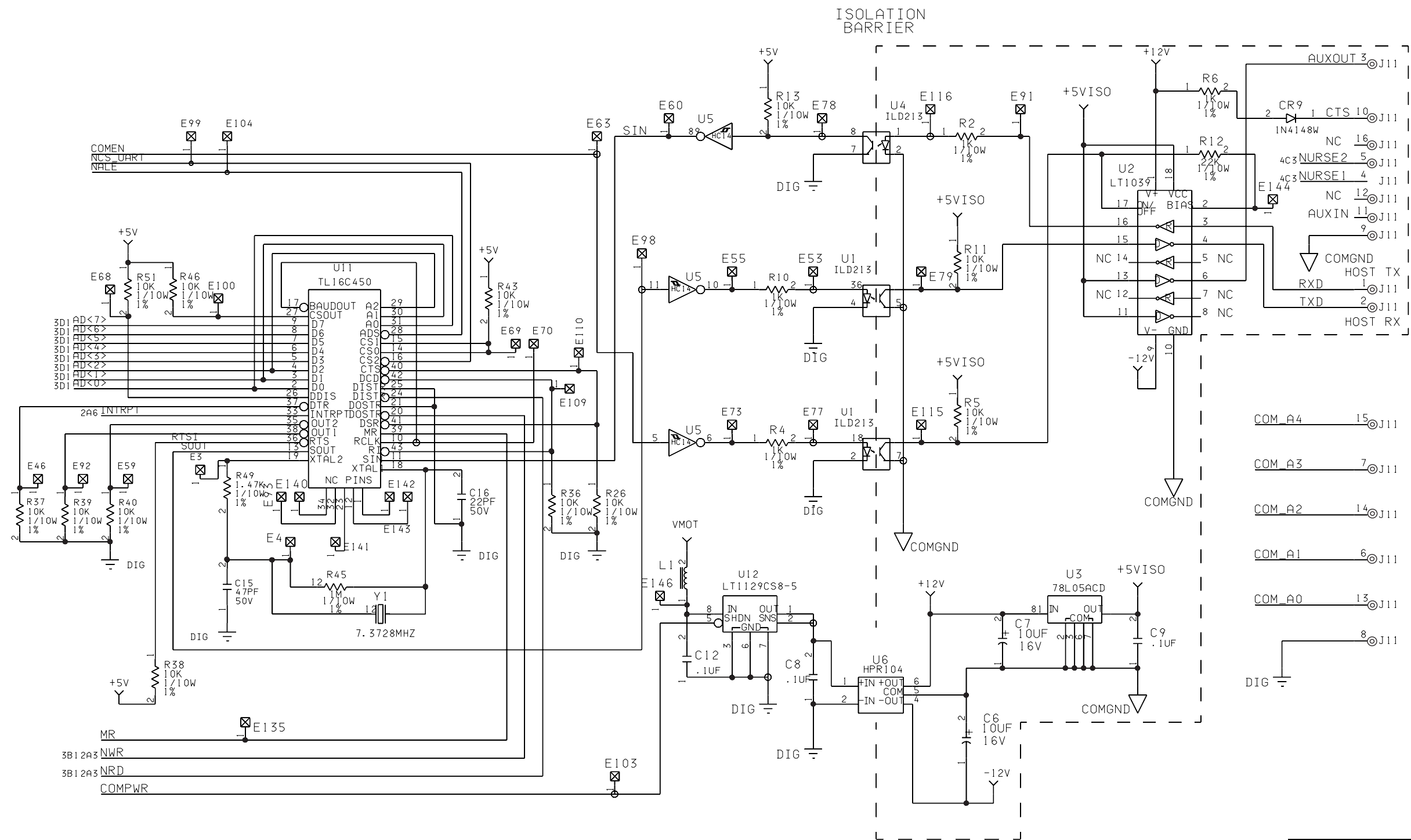

HOSPIRA, INC.
 Figure 9-17. MCU PWA Schematic (XLM with DataPort)

| | |
|---------------|----------------|
| DRAWING NO. | Rev. C |
| 249-05701-002 | Sheet 16 of 18 |

This page intentionally left blank.

PROBE PADS

| | | | | |
|-------------|-------------|---|---|-----|
| 2B4 | DIST_AIR_EN | 1 | ⊗ | E65 |
| 2B4 | PROX_AIR_EN | 1 | ⊗ | E66 |
| 2B4 | BUZZER | 1 | ⊗ | E1 |
| 2B4 2A5 | NP_S_EN | 1 | ⊗ | E17 |
| 2B4 | WR_NRD | 1 | ⊗ | E75 |
| 4A4 2B4 | PS_VALVE | 1 | ⊗ | E76 |
| 3B1 2A3 | ALE | 1 | ⊗ | E62 |
| 3B1 2A3 | NWR | 1 | ⊗ | E81 |
| 3B1 2A3 | NRD | 1 | ⊗ | E82 |
| 3B1 3A4 2A4 | NRST | 1 | ⊗ | E83 |
| 3C1 3A5 | DSPSTIN | 1 | ⊗ | E64 |
| 3C1 3B5 | DHKDC | 1 | ⊗ | E67 |
| 2D5 | FPROXPRES | 1 | ⊗ | E8 |
| 2D6 | FDISTPRES | 1 | ⊗ | E9 |
| 2D6 | NFAIR_OPT | 1 | ⊗ | E10 |
| 2B6 | DIVVMOT | 1 | ⊗ | E11 |
| 2B6 | FBUZTST | 1 | ⊗ | E12 |
| 2C7 | DIVHKDC | 1 | ⊗ | E13 |
| 2C7 | DIVVDIG | 1 | ⊗ | E14 |
| 2D5 | 2V5REF | 1 | ⊗ | E15 |

| | | | | |
|-----|--------|---|---|-----|
| 3D1 | AD<15> | 1 | ⊗ | E24 |
| 3D1 | AD<14> | 1 | ⊗ | E25 |
| 3D1 | AD<13> | 1 | ⊗ | E26 |
| 3D1 | AD<12> | 1 | ⊗ | E27 |
| 3D1 | AD<11> | 1 | ⊗ | E28 |
| 3D1 | AD<10> | 1 | ⊗ | E29 |
| 3D1 | AD<9> | 1 | ⊗ | E30 |
| 3D1 | AD<8> | 1 | ⊗ | E31 |
| 3D1 | AD<7> | 1 | ⊗ | E32 |
| 3D1 | AD<6> | 1 | ⊗ | E33 |
| 3D1 | AD<5> | 1 | ⊗ | E34 |
| 3D1 | AD<4> | 1 | ⊗ | E35 |
| 3D1 | AD<3> | 1 | ⊗ | E36 |
| 3D1 | AD<2> | 1 | ⊗ | E37 |
| 3D1 | AD<1> | 1 | ⊗ | E38 |
| 3D1 | AD<0> | 1 | ⊗ | E39 |

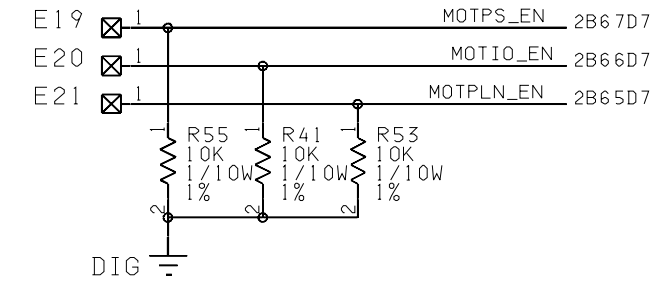
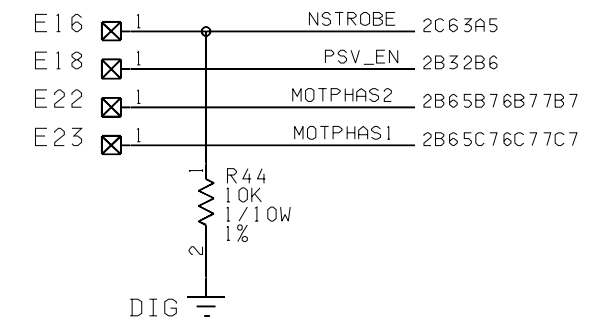

| HOSPIRA, INC. | |
|--|----------------|
| Figure 9-17. MCU PWA Schematic (XLM with DataPort) | |
| DRAWING NO. | Rev. C |
| 249-05701-002 | Sheet 17 of 18 |

This page intentionally left blank.

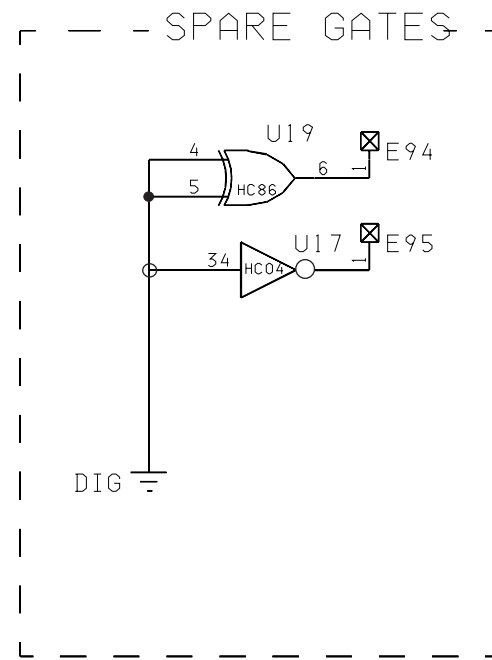
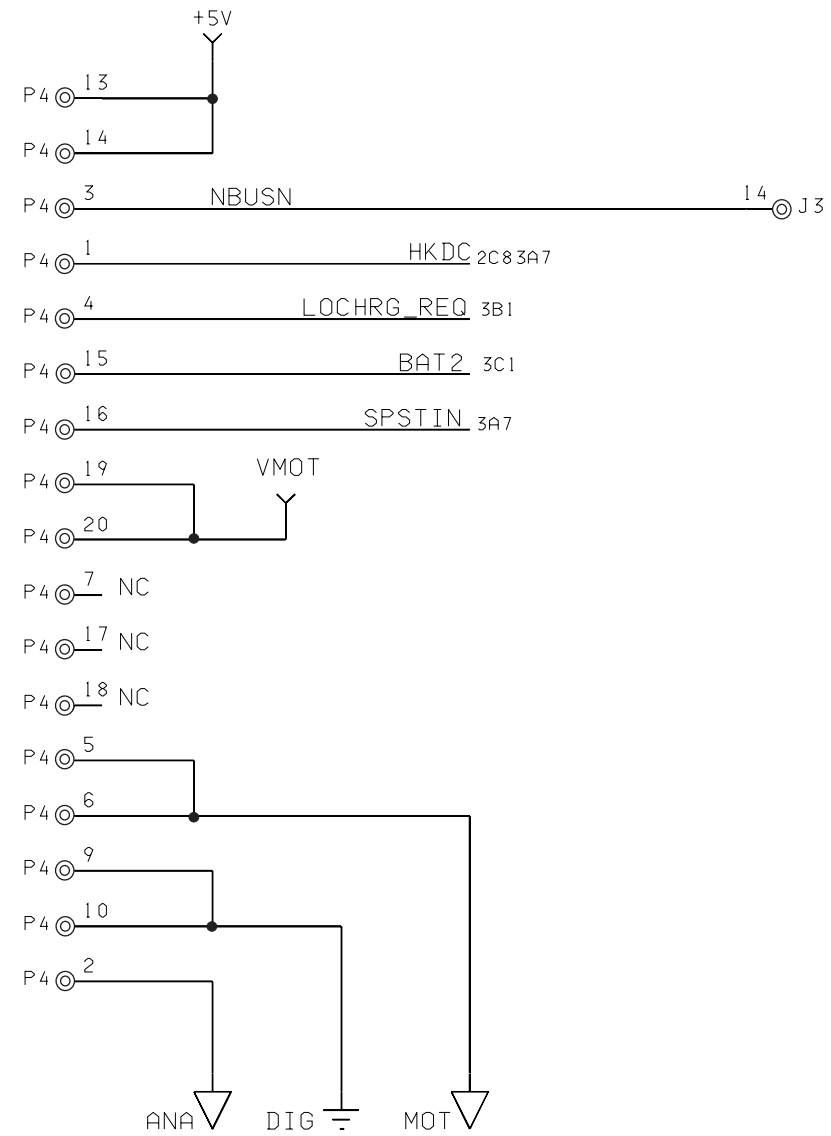
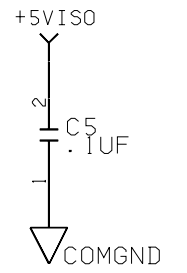
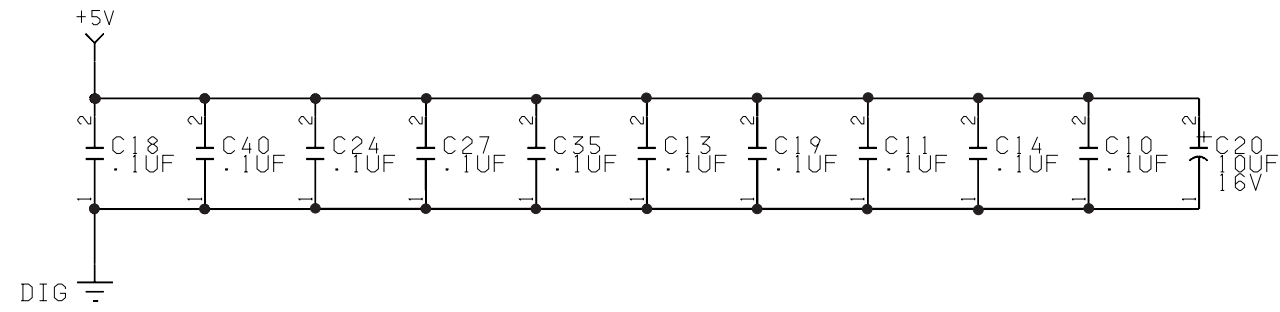
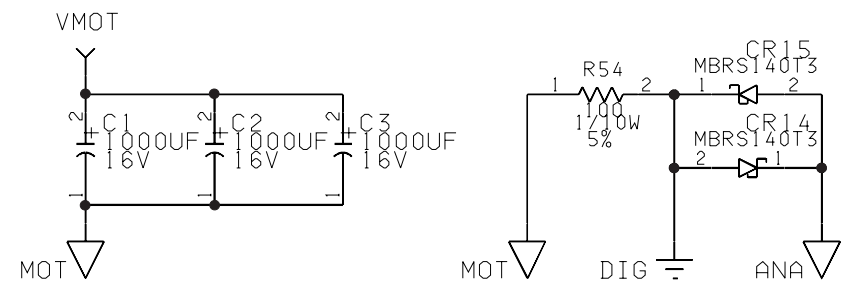

| | |
|---|--------------------------|
| HOSPIRA, INC. | |
| Figure 9-17. MCU PWA Schematic (XLM with DataPort) | |
| DRAWING NO. 249-05701-002 | Rev. C Sheet 18 of 18 |

This page intentionally left blank.

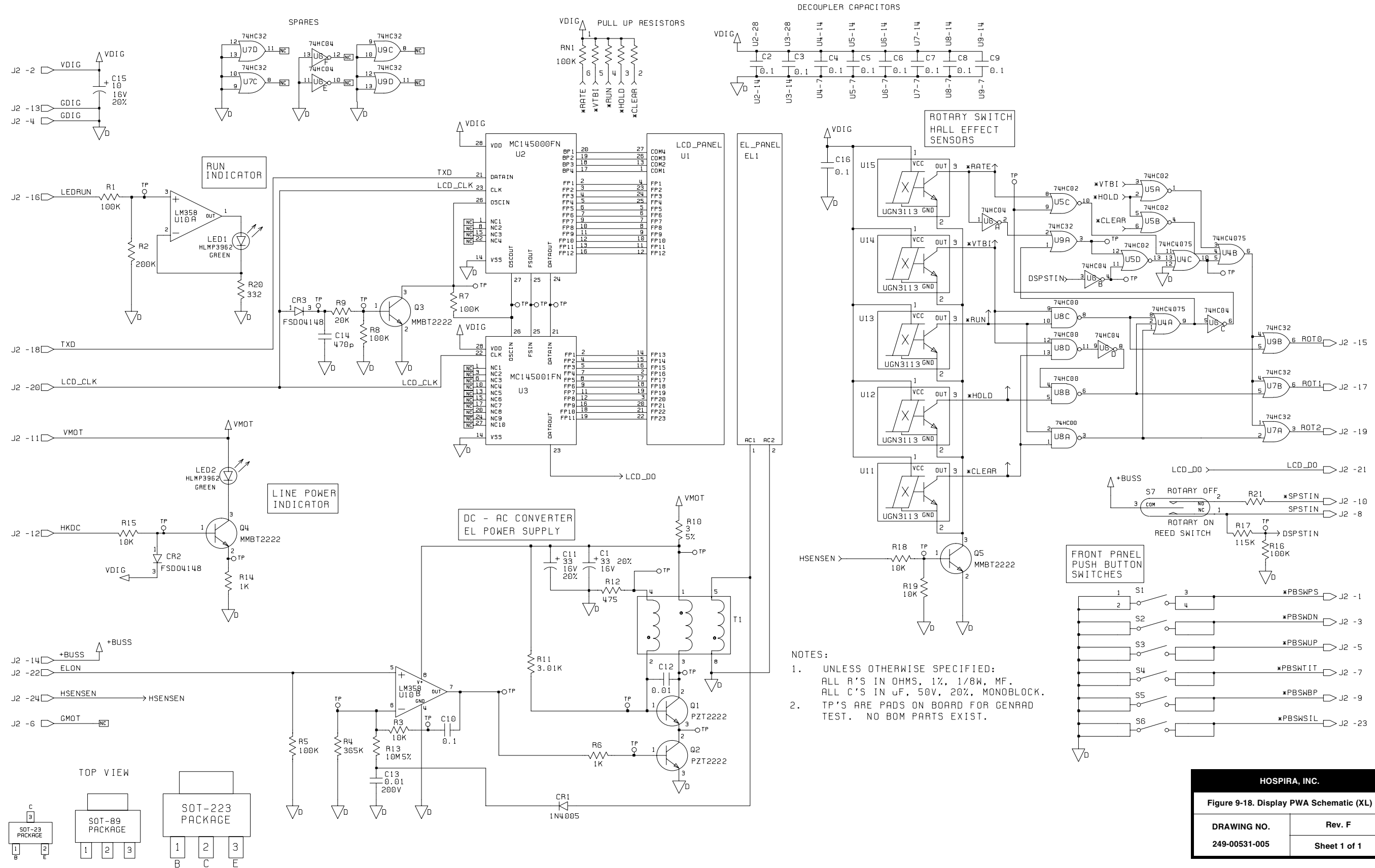

This page intentionally left blank.

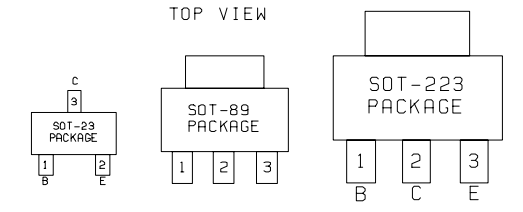
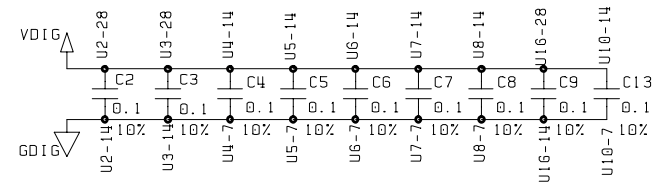
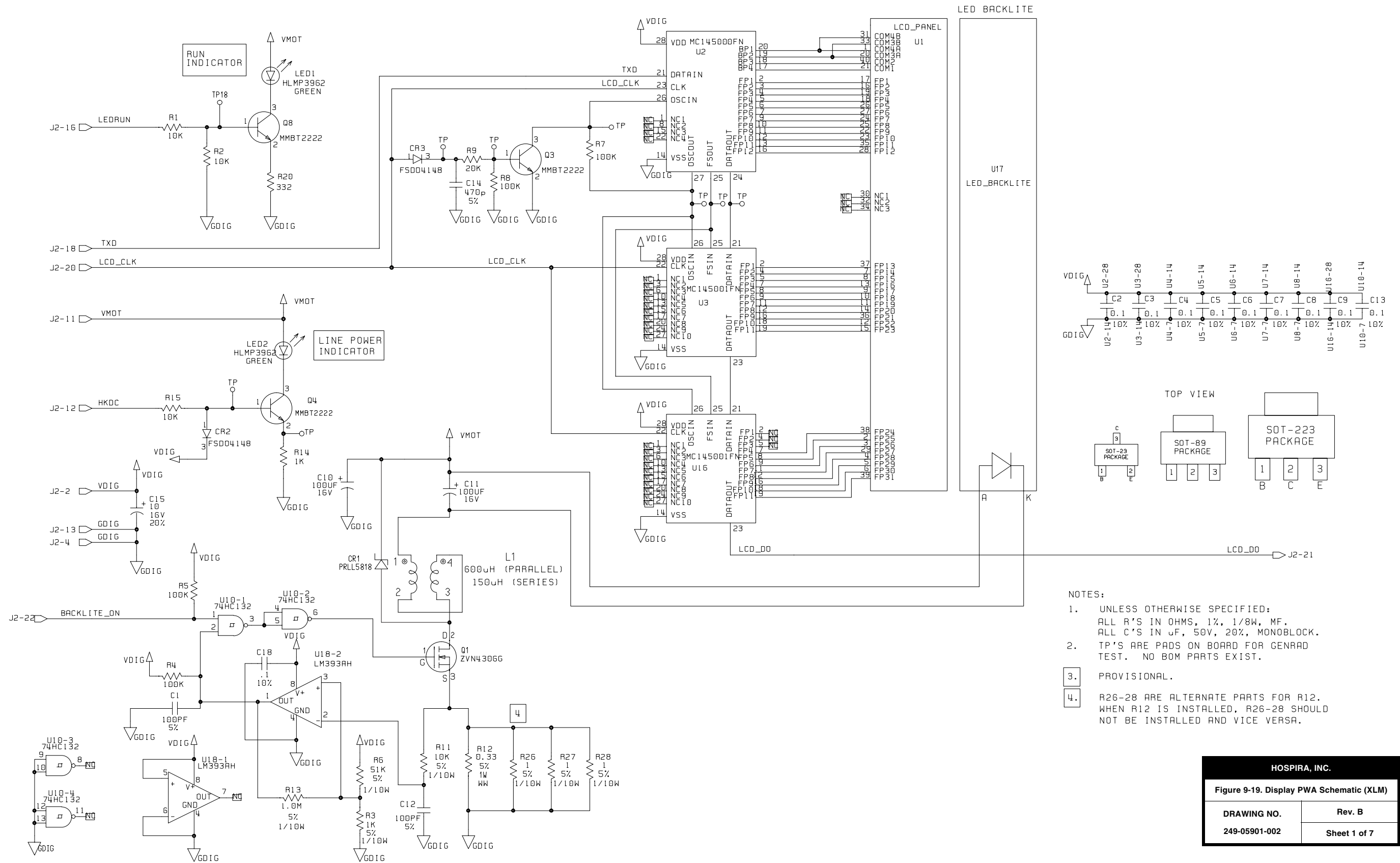

- NOTES:
- UNLESS OTHERWISE SPECIFIED:
ALL R'S IN OHMS, 1%, 1/8W, MF.
ALL C'S IN µF, 50V, 20%, MONOBLOCK.
 - TP'S ARE PADS ON BOARD FOR GENRAD TEST. NO BOM PARTS EXIST.
 - PROVISIONAL.
 - R26-28 ARE ALTERNATE PARTS FOR R12. WHEN R12 IS INSTALLED, R26-28 SHOULD NOT BE INSTALLED AND VICE VERSA.

| HOSPIRA, INC. | |
|--|--------------|
| Figure 9-19. Display PWA Schematic (XLM) | |
| DRAWING NO. | Rev. B |
| 249-05901-002 | Sheet 1 of 7 |

This page intentionally left blank.

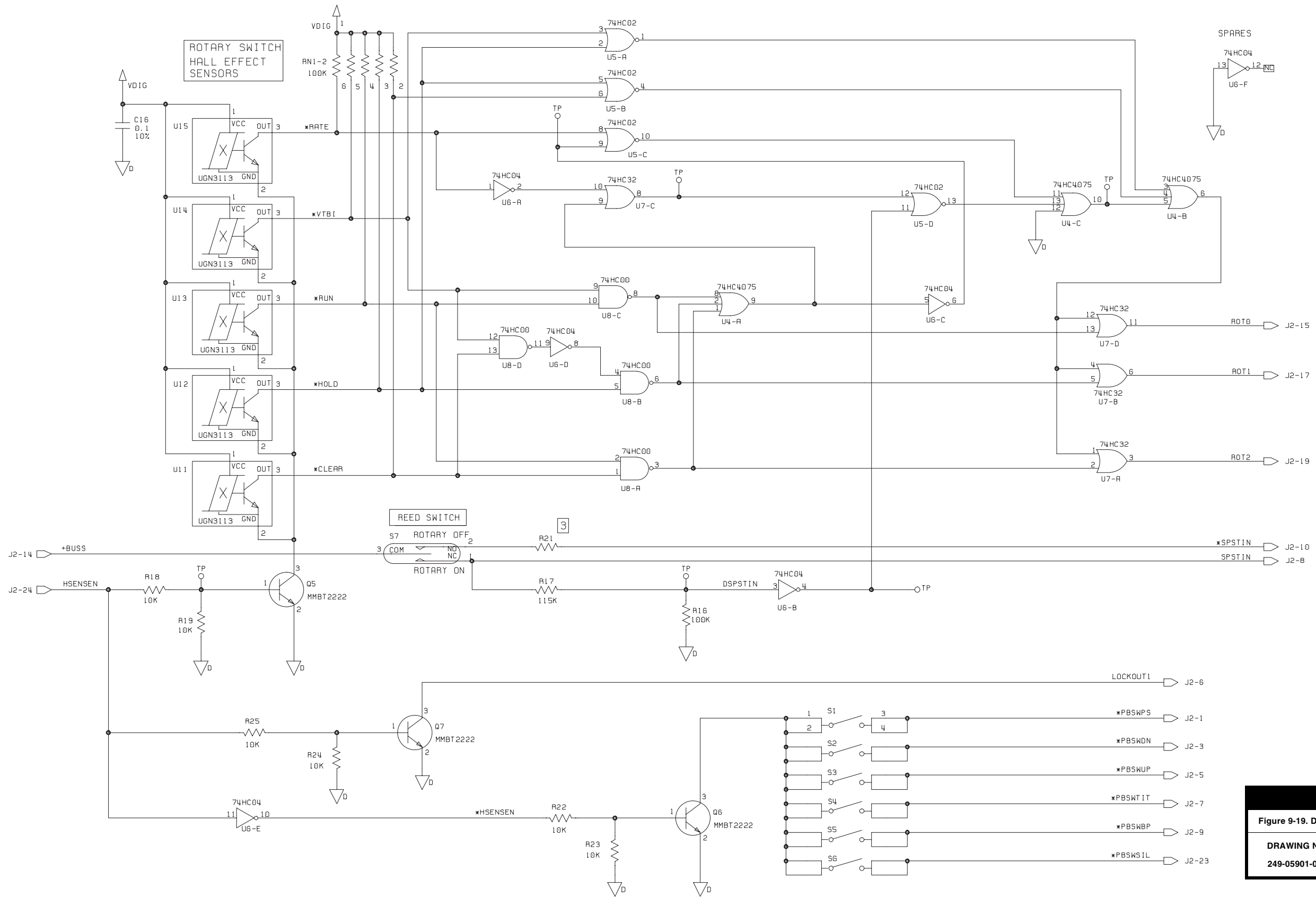

HOSPIRA, INC.
Figure 9-19. Display PWA Schematic (XLM)

| | |
|---------------|--------------|
| DRAWING NO. | Rev. B |
| 249-05901-002 | Sheet 2 of 7 |

This page intentionally left blank.

| POWER AND GROUND LIST - 1 | | | |
|---------------------------|-----------------|-----|-----|
| DESIGNATOR | PART TYPE | GND | VCC |
| U1 | 74HC132-S014 | 7 | 14 |
| U6 | PALCE16V8Z-25JC | 10 | 20 |
| END POWER AND GROUND LIST | | | |

NOTES UNLESS OTHERWISE SPECIFIED

1. ALL CAPACITORS ARE IN μF , 1206, 10%, 50V.
2. ALL RESISTORS ARE IN OHMS, 0805, 5%, 1/10W.

SPARES

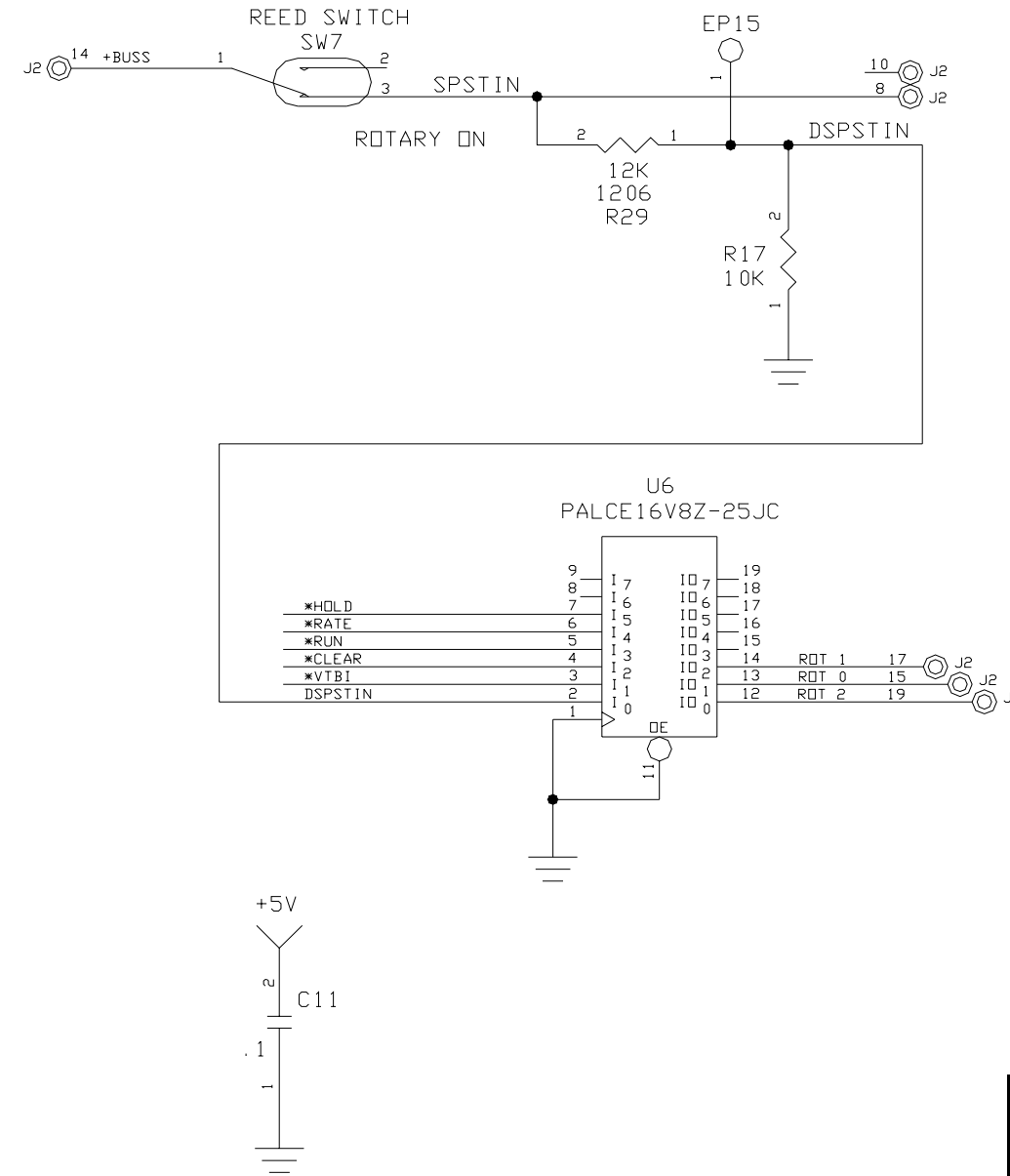
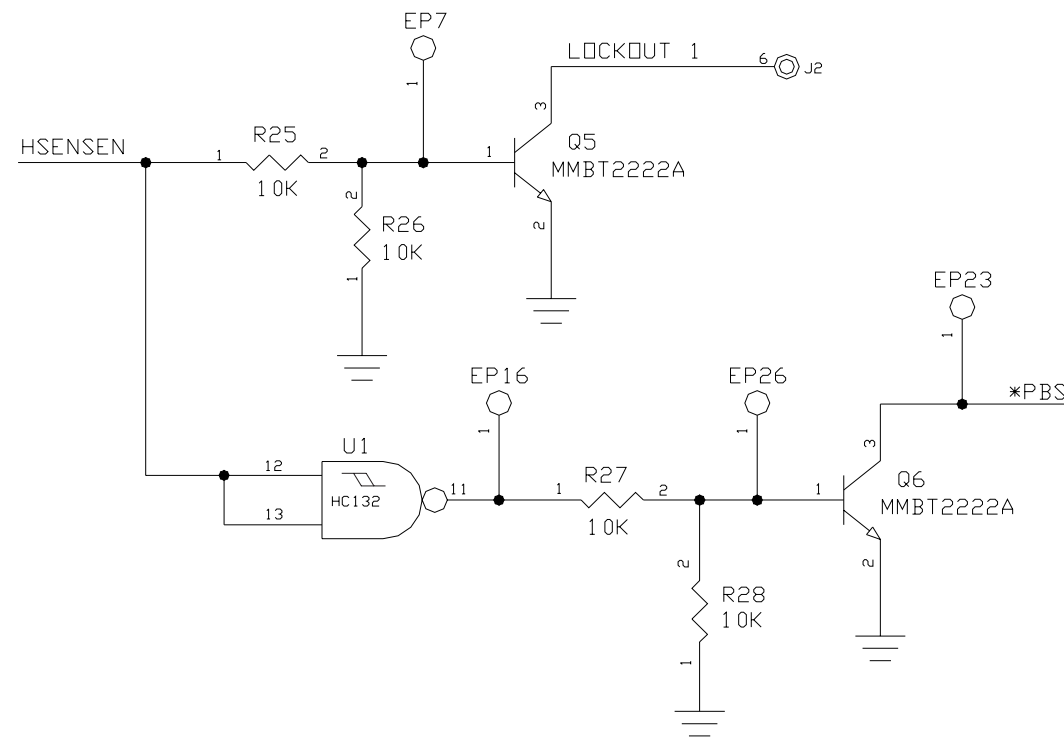
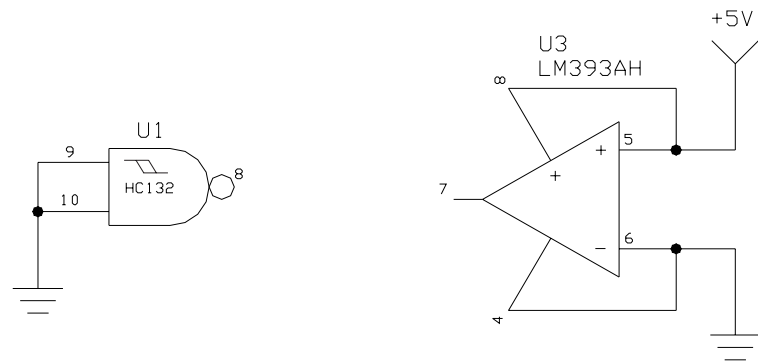

| | |
|--|--------------|
| HOSPIRA, INC. | |
| Figure 9-19. Display PWA Schematic (XLM) | |
| DRAWING NO. | Rev. C |
| 249-05901-003 | Sheet 3 of 7 |

This page intentionally left blank.

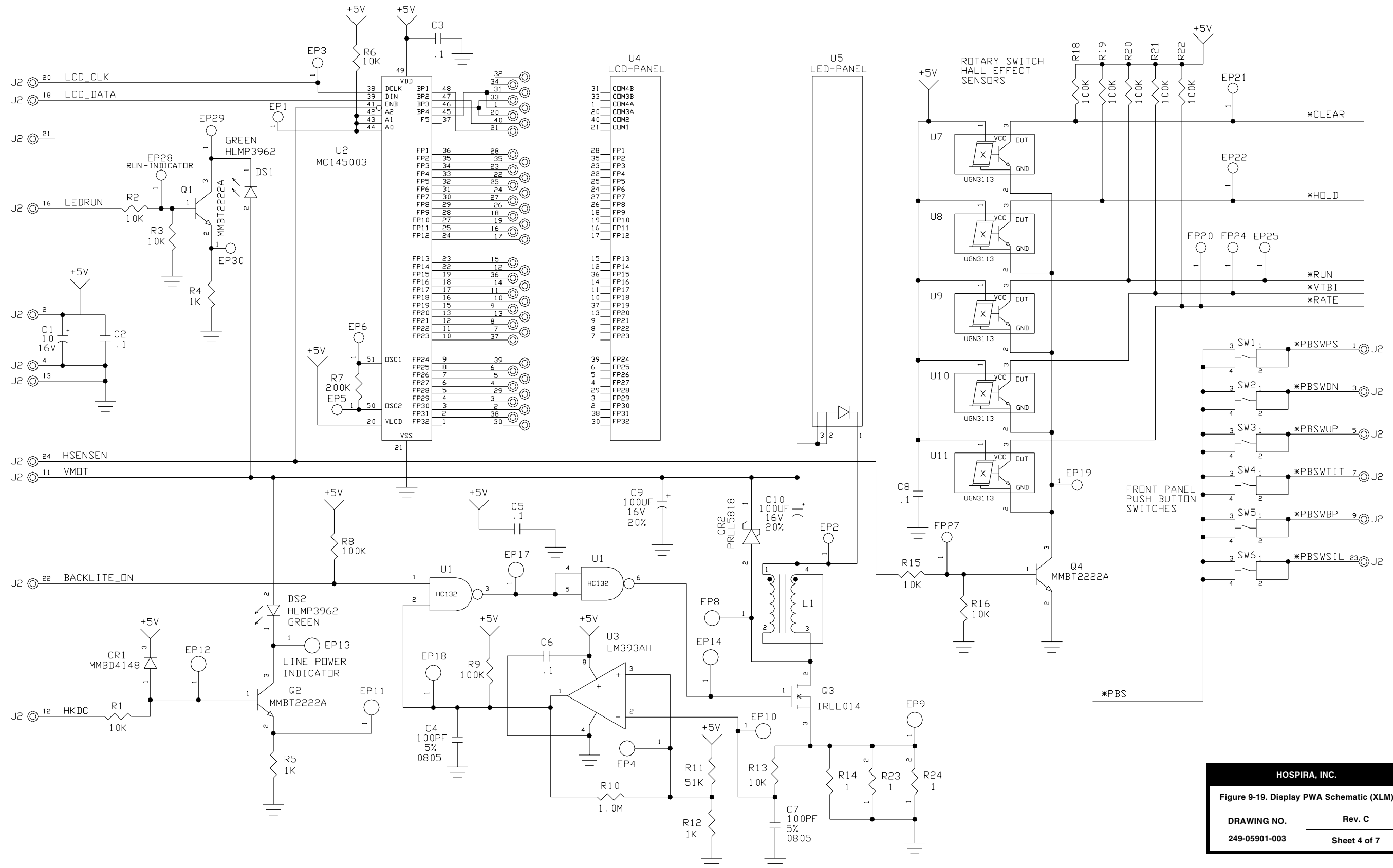

This page intentionally left blank.

SPARES

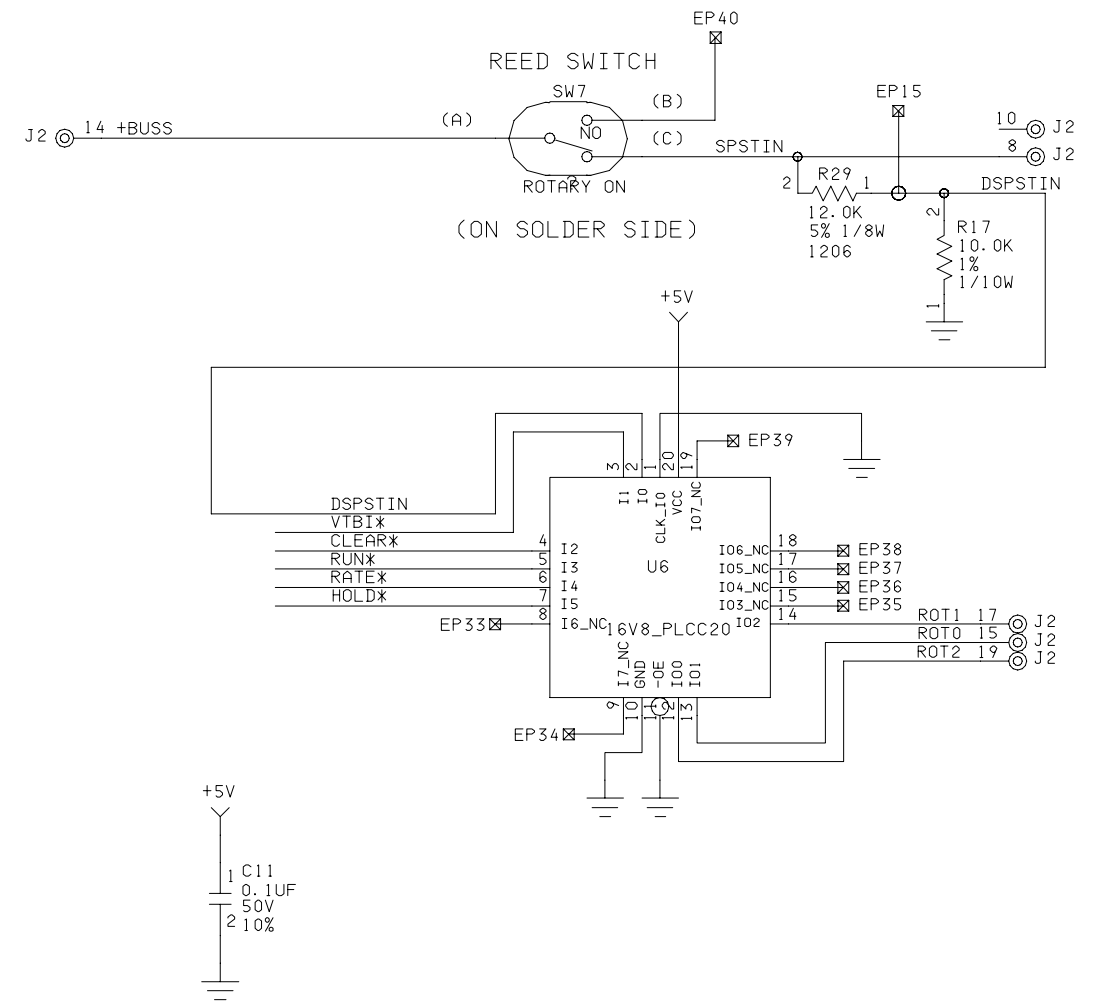
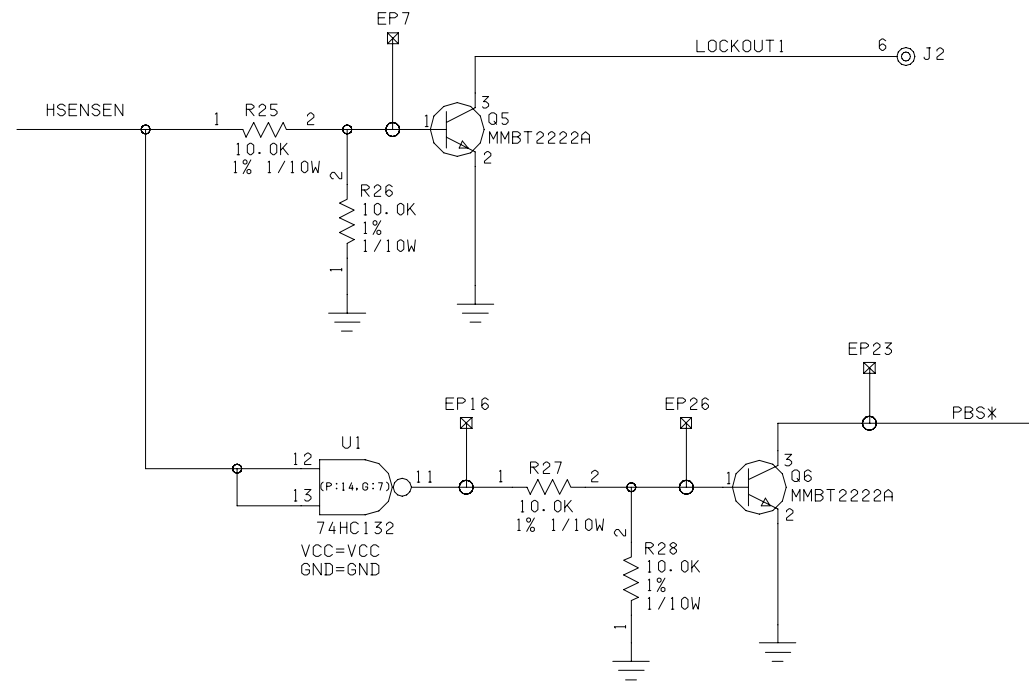
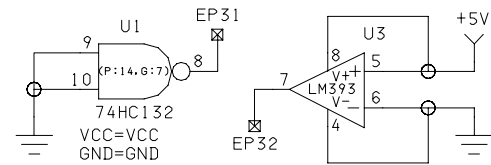

| | |
|--|--------------|
| HOSPIRA, INC. | |
| Figure 9-19. Display PWA Schematic (XLM) | |
| DRAWING NO. | Rev. B |
| 249-05901-004 | Sheet 5 of 7 |

This page intentionally left blank.

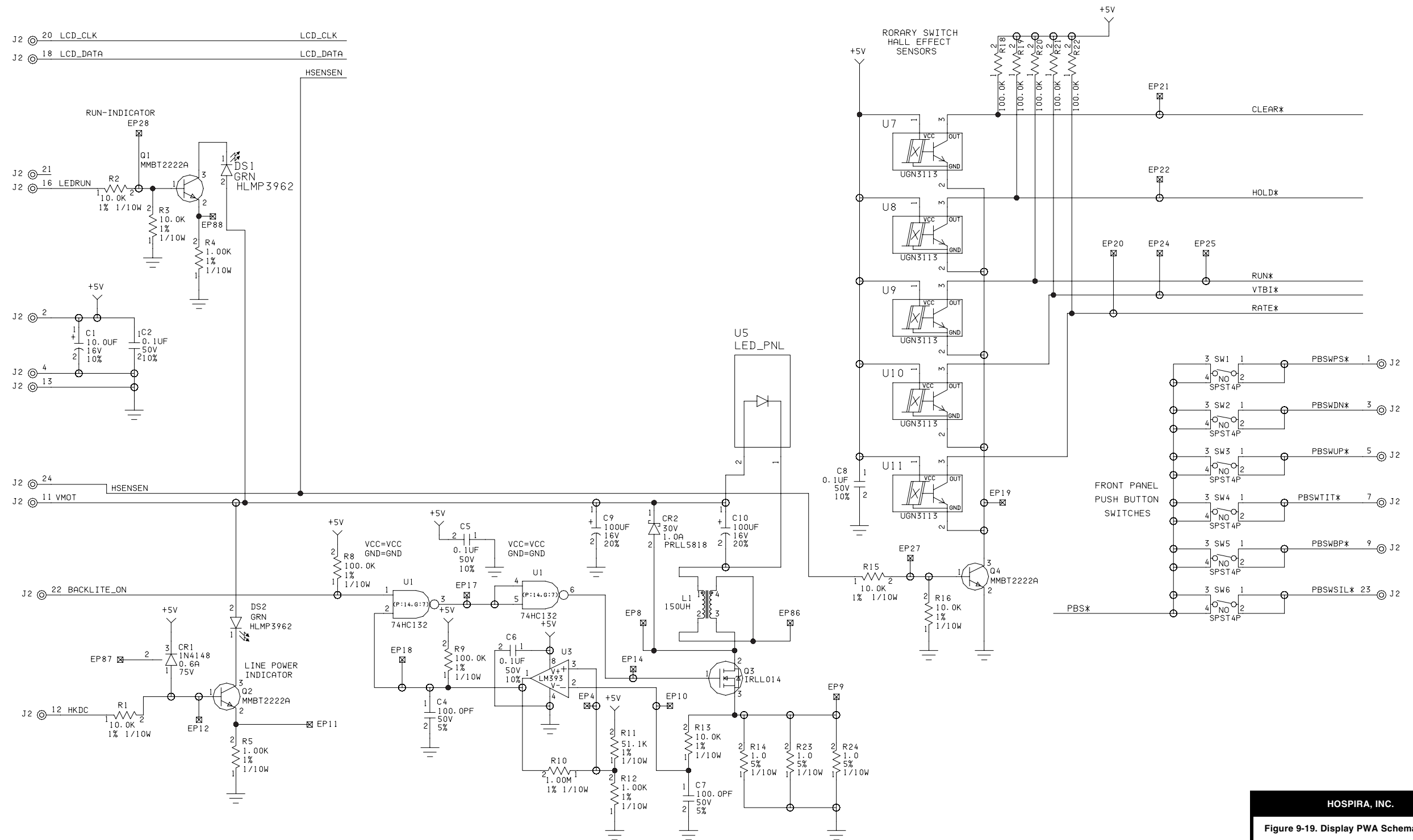

HOSPIRA, INC.

Figure 9-19. Display PWA Schematic (XLM)

| | |
|--------------------|---------------|
| DRAWING NO. | Rev. B |
| 249-05901-004 | Sheet 6 of 7 |

This page intentionally left blank.

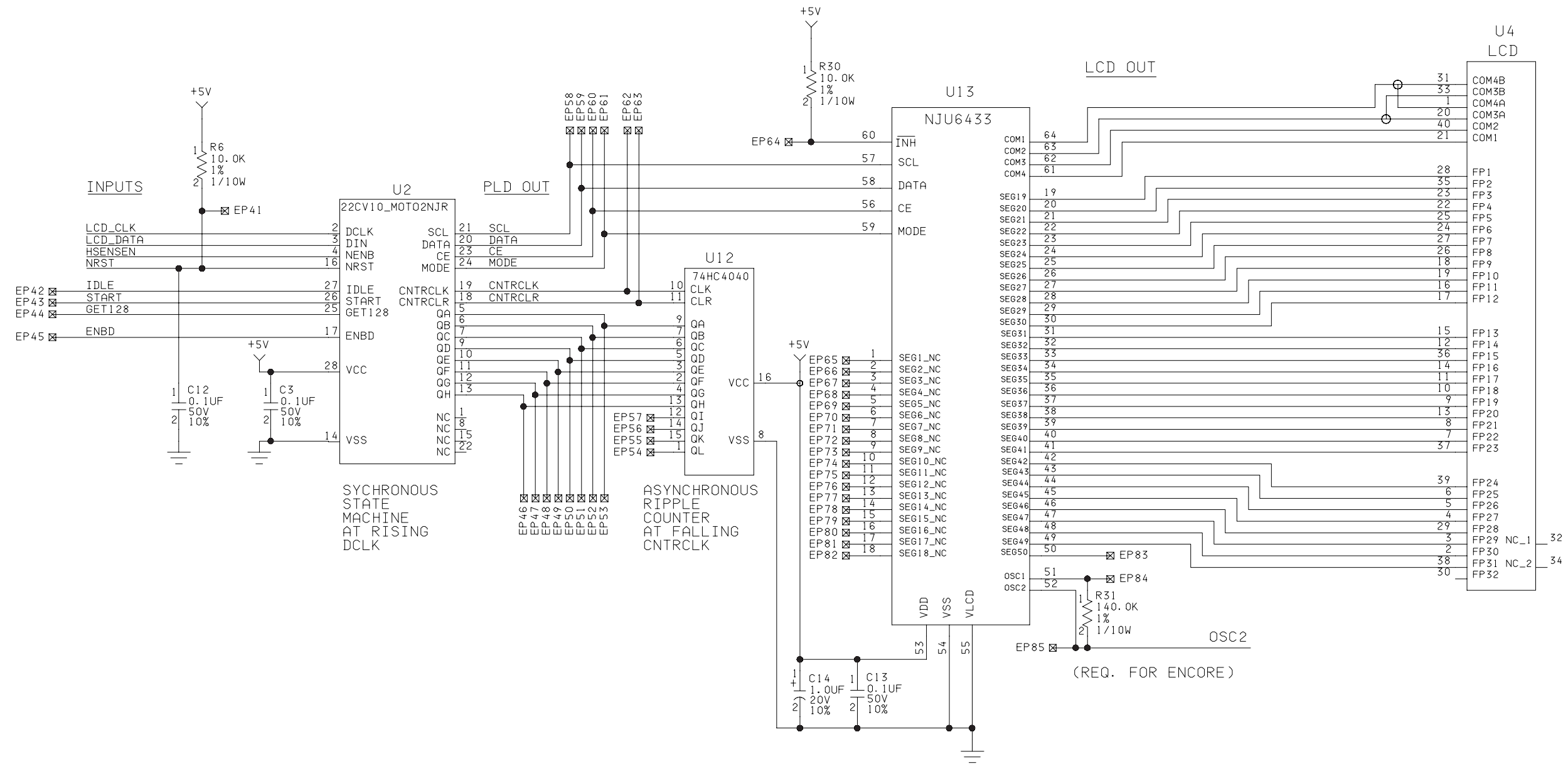

HOSPIRA, INC.
Figure 9-19. Display PWA Schematic (XLM)

| | |
|---------------|--------------|
| DRAWING NO. | Rev. B |
| 249-05901-004 | Sheet 7 of 7 |

This page intentionally left blank.

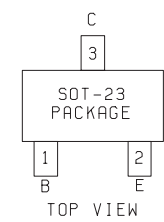
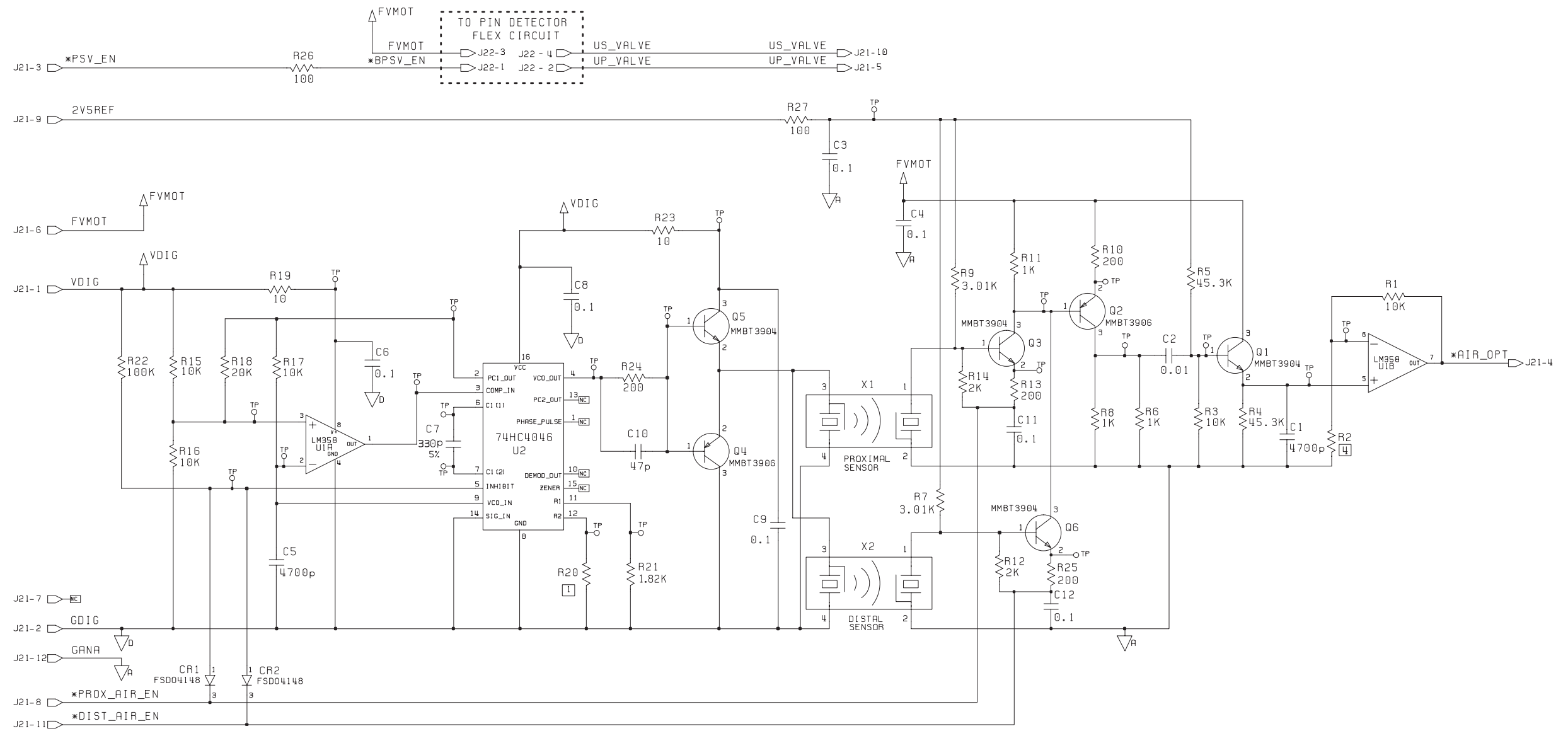

| | |
|--|--------------|
| HOSPIRA, INC. | |
| Figure 9-20. Bubble Sensor PWA Schematic | |
| DRAWING NO. | Rev. L |
| 249-00536-005 | Sheet 1 of 3 |

This page intentionally left blank.

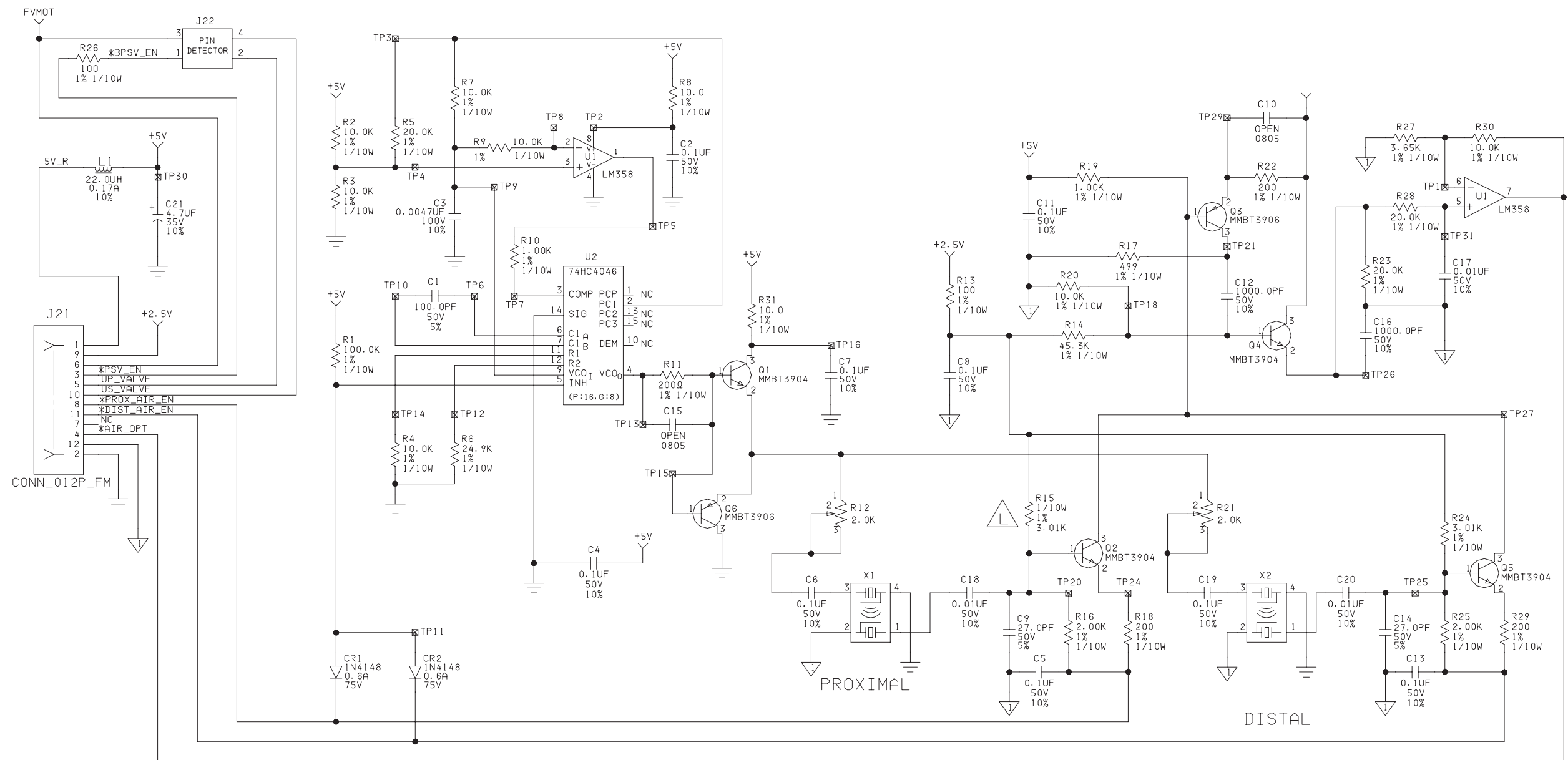

HOSPIRA, INC.

Figure 9-20. Bubble Sensor PWA Schematic

| | |
|--------------------|---------------|
| DRAWING NO. | Rev. L |
| 249-00536-007 | Sheet 2 of 3 |

This page intentionally left blank.

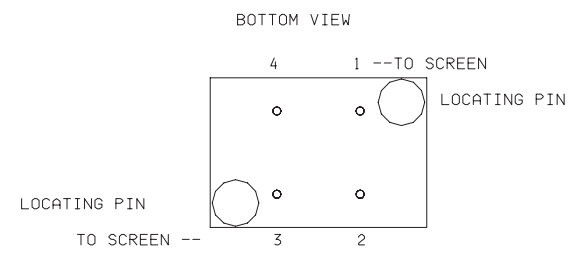
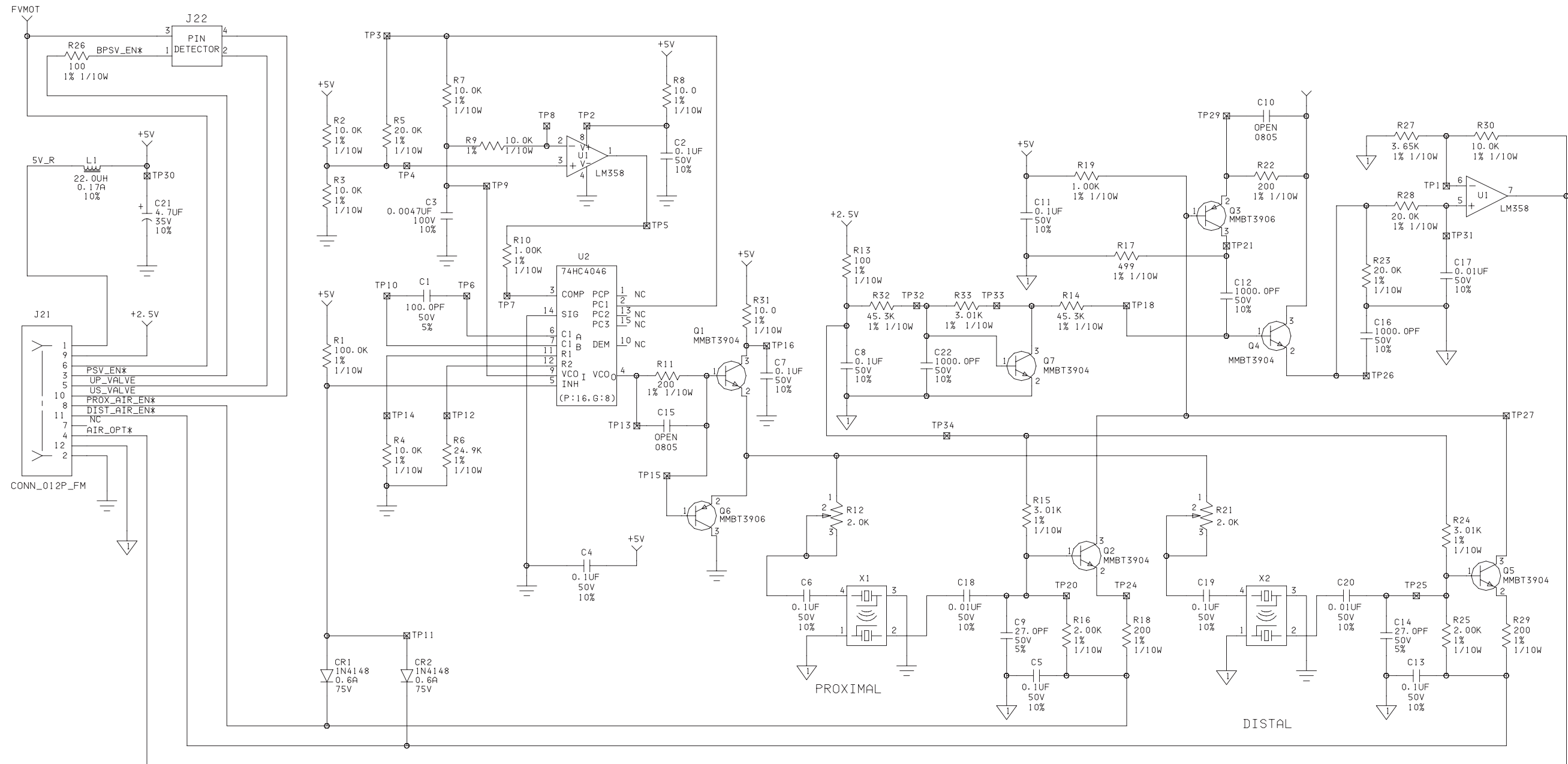

| HOSPIRA, INC. | |
|--|--------------|
| Figure 9-20. Bubble Sensor PWA Schematic | |
| DRAWING NO. | Rev. L |
| 249-00536-008 | Sheet 3 of 3 |

This page intentionally left blank.

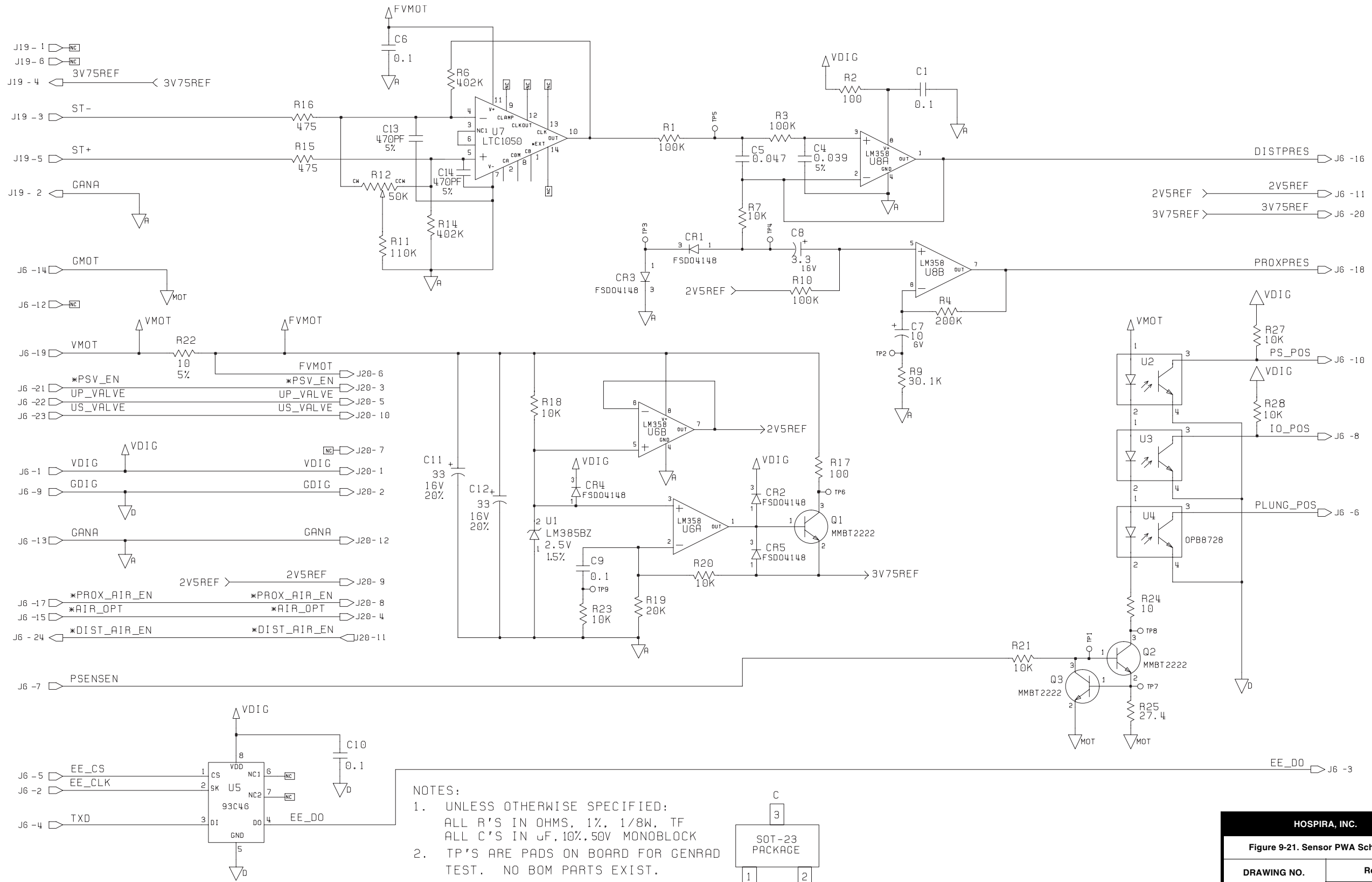

NOTES:
 1. UNLESS OTHERWISE SPECIFIED:
 ALL R'S IN OHMS, 1%, 1/8W, TF
 ALL C'S IN μ F, 10%, 50V MONOBLOCK
 2. TP'S ARE PADS ON BOARD FOR GENRAD
 TEST. NO BOM PARTS EXIST.

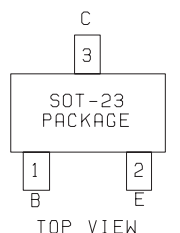

| HOSPIRA, INC. | |
|-----------------------------------|--------------|
| Figure 9-21. Sensor PWA Schematic | |
| DRAWING NO. | Rev. J |
| 249-00538-006 | Sheet 1 of 1 |

This page intentionally left blank.

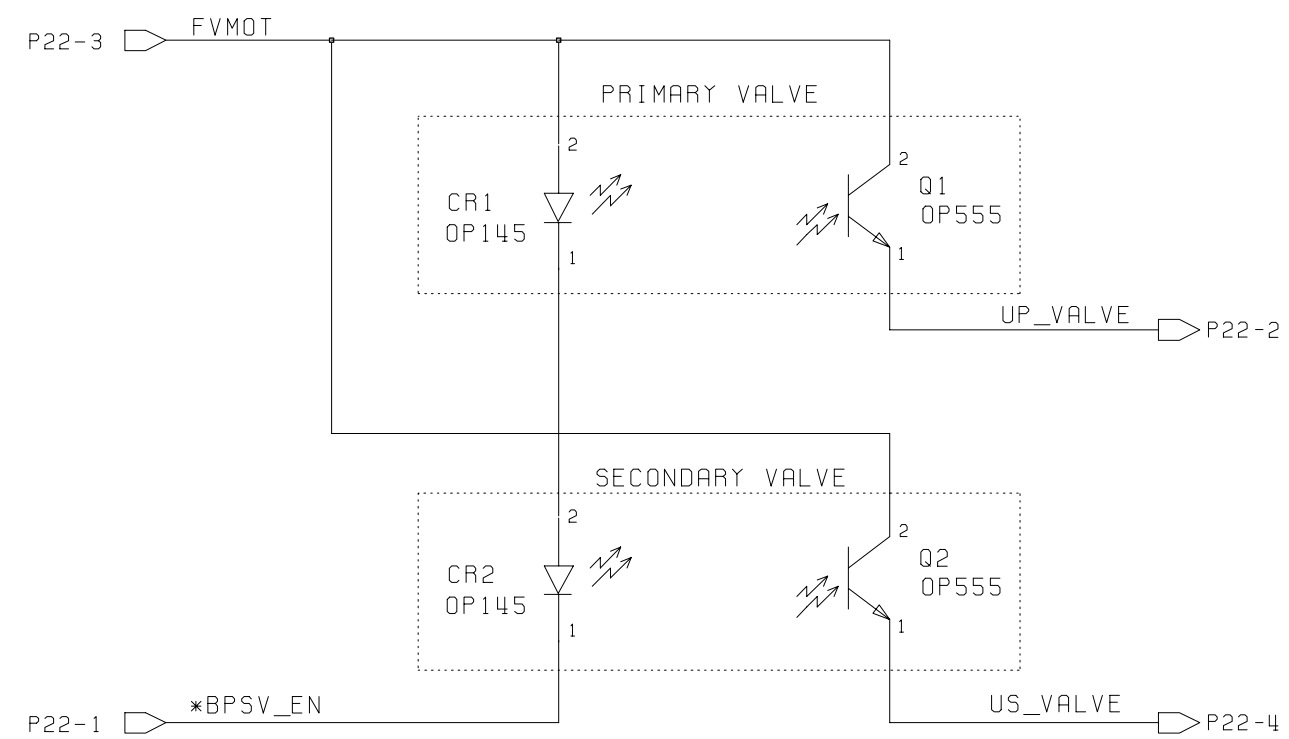

| | |
|--|------------------------|
| HOSPIRA, INC. | |
| Figure 9-22. Pin Detector Flex Circuit Schematic | |
| DRAWING NO. 249-00539-001 | Rev. B Sheet 1 of 1 |

This page intentionally left blank.

This page intentionally left blank.

This page intentionally left blank.

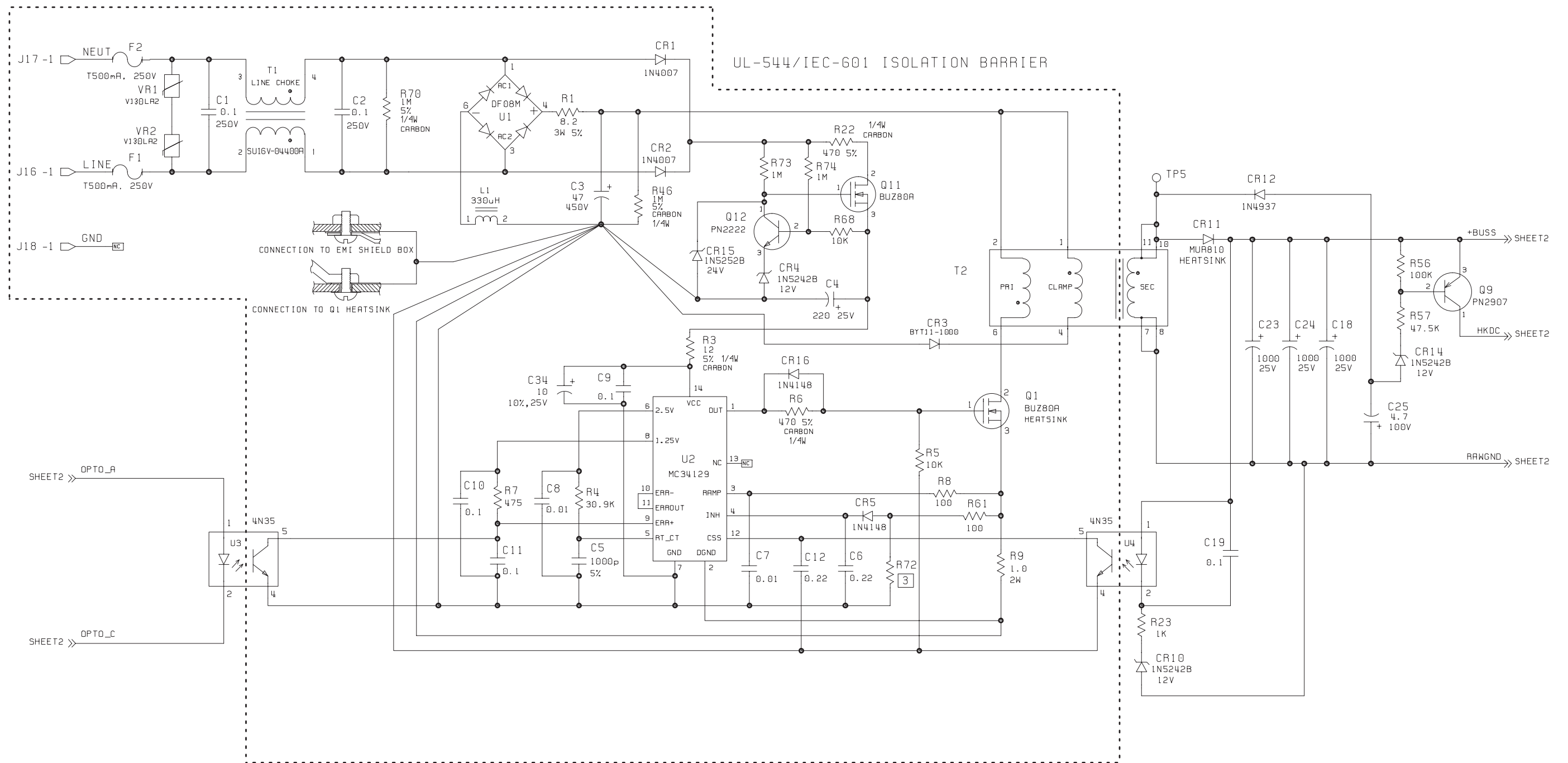

- NOTES:
1. UNLESS OTHERWISE SPECIFIED:
ALL R'S IN OHMS, MF, 1%, 1/8W
ALL C'S IN μ F, 20%, 50V.
 2. J26 PINS 3 AND 4 ARE SHORTED
AT BATTERY'S CONNECTOR WHEN
USING PANASONIC BATTERY.
 3. CR17, R72 PROVISIONAL.

| | |
|---|------------------------|
| HOSPIRA, INC. | |
| Figure 9-24. Power Supply PWA Schematic (XL International) | |
| DRAWING NO. 249-00573-004 | Rev. G Sheet 1 of 2 |

This page intentionally left blank.

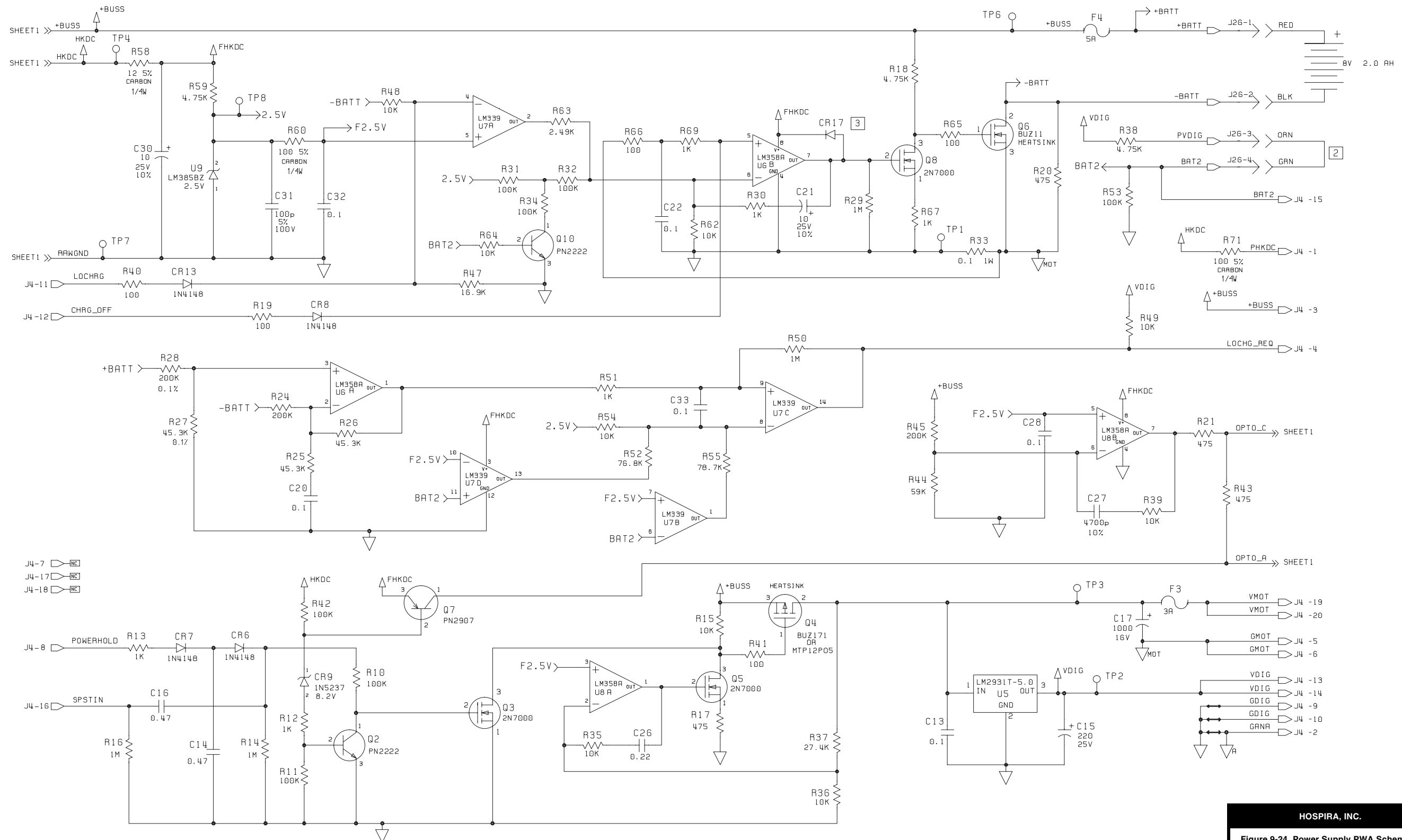

HOSPIRA, INC.
Figure 9-24. Power Supply PWA Schematic (XL - International)

| | |
|---------------|--------------|
| DRAWING NO. | Rev. G |
| 249-00573-004 | Sheet 2 of 2 |

This page intentionally left blank.

This page intentionally left blank.

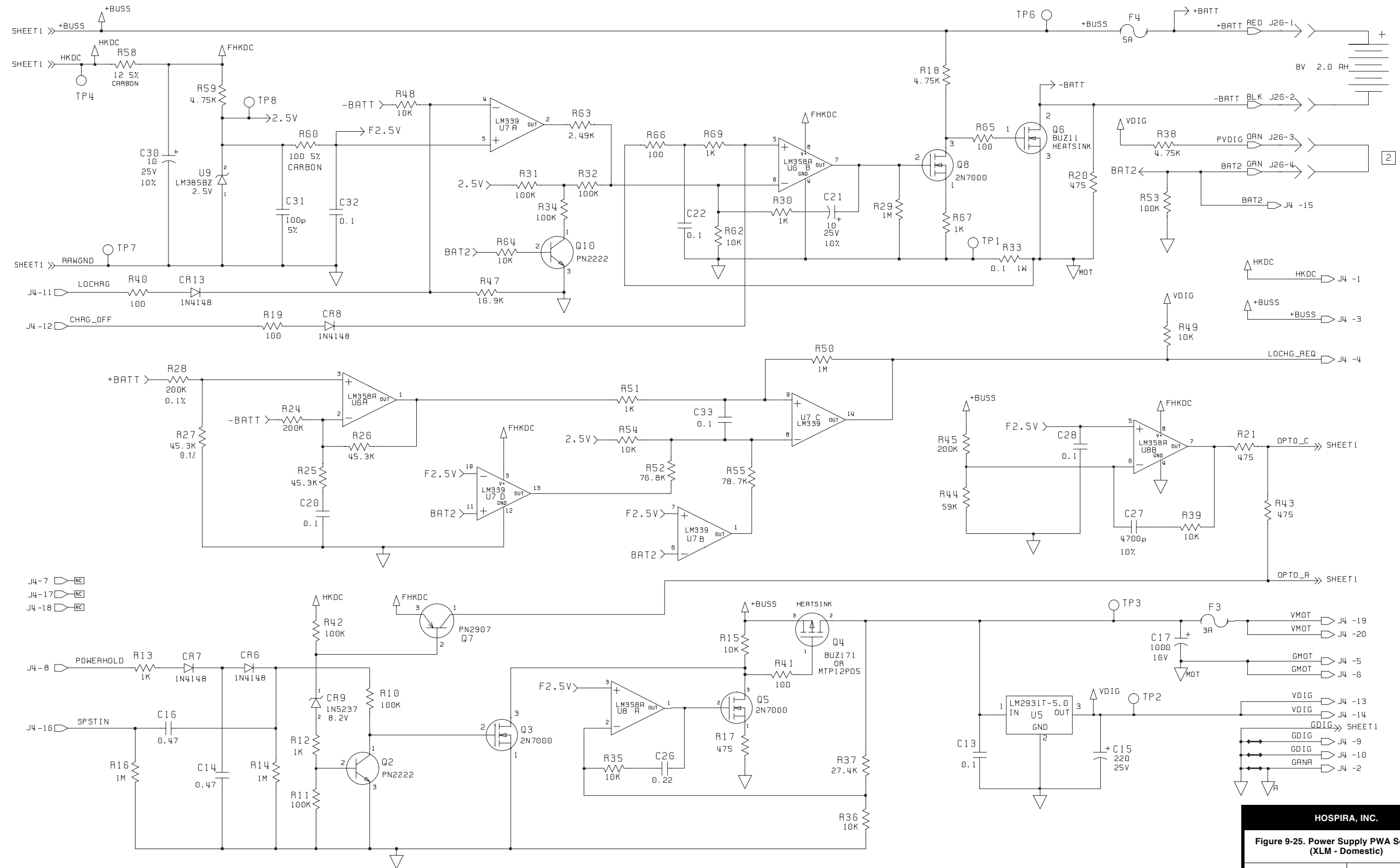

HOSPIRA, INC.
Figure 9-25. Power Supply PWA Schematic (XL8 - Domestic)

| | |
|---------------|--------------|
| DRAWING NO. | Rev. B |
| 249-05920-002 | Sheet 2 of 2 |

This page intentionally left blank.

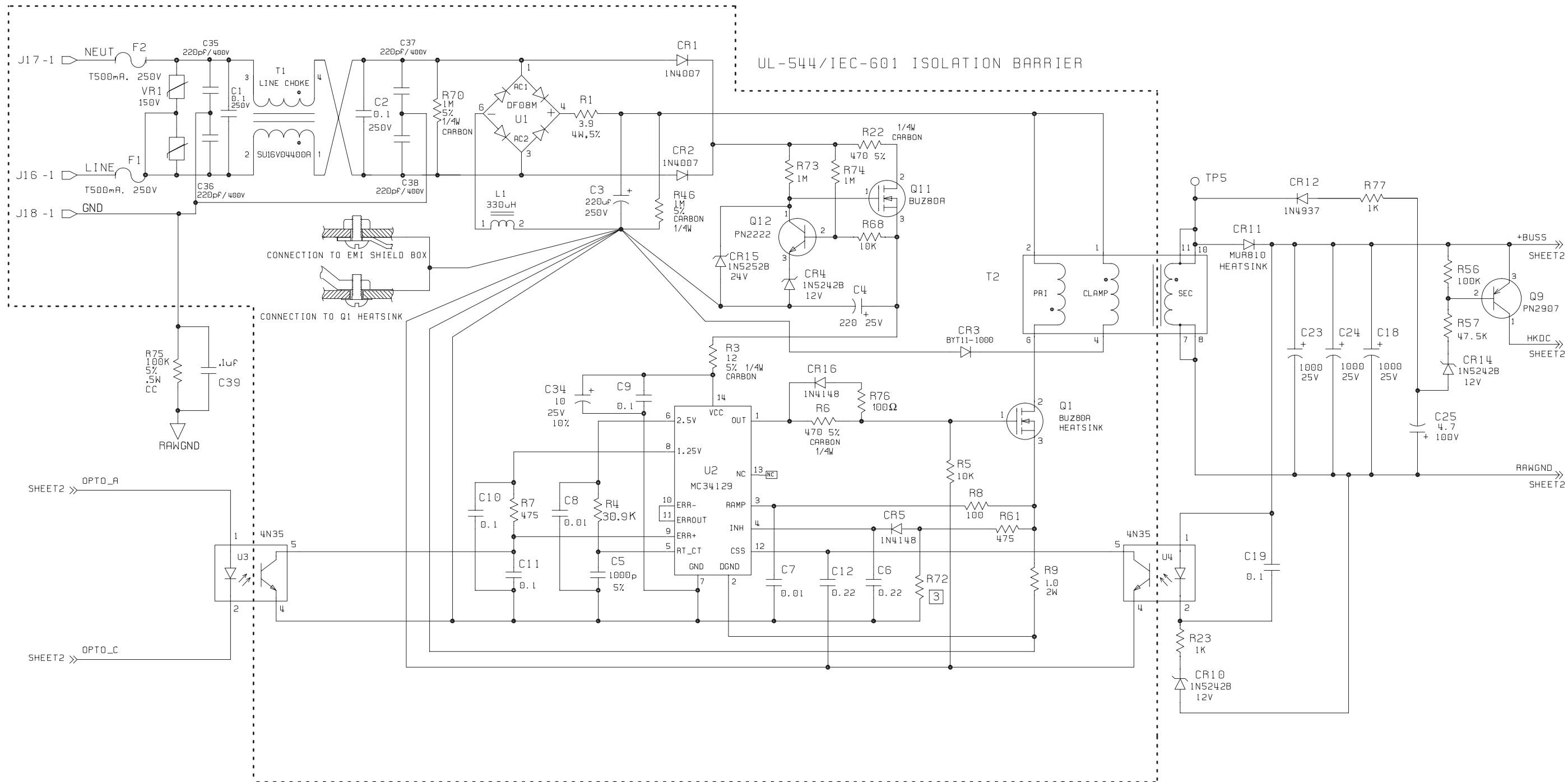

NOTES:

1. UNLESS OTHERWISE SPECIFIED:
ALL R'S IN OHMS, MF, 1%, 1/8W
ALL C'S IN μ F, 20%, 50V.
2. J26 PINS 3 AND 4 ARE SHORTED
AT BATTERY'S CONNECTOR WHEN
USING PANASONIC BATTERY.
3. CR17, R72 PROVISIONAL.

| | |
|--|------------------------|
| HOSPIRA, INC. | |
| Figure 9-26. Power Supply PWA Schematic (XLM International) | |
| DRAWING NO. 249-05916-003 | Rev. H Sheet 1 of 4 |

This page intentionally left blank.

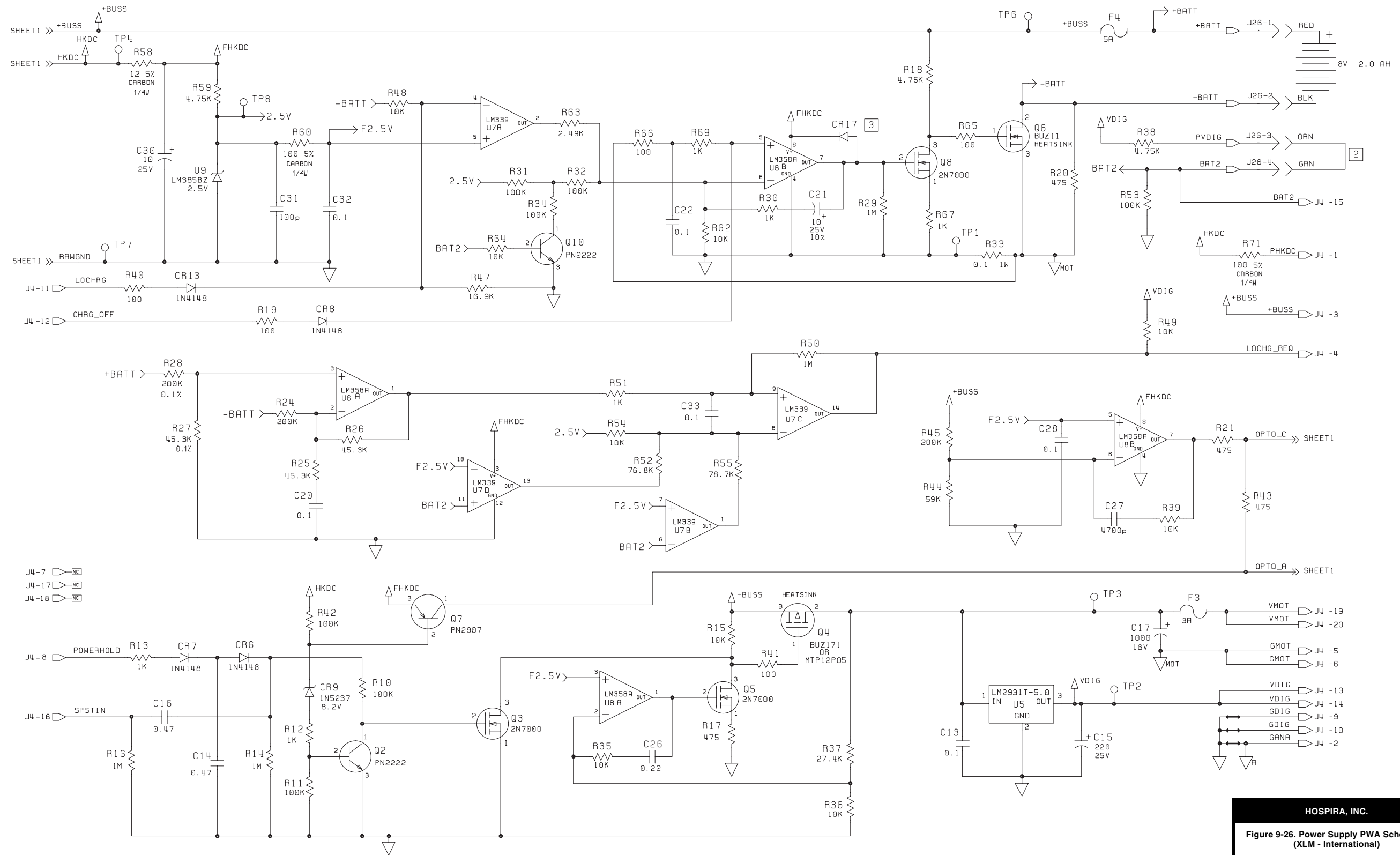

HOSPIRA, INC.
Figure 9-26. Power Supply PWA Schematic (XLM - International)

| | |
|---------------|--------------|
| DRAWING NO. | Rev. H |
| 249-05916-003 | Sheet 2 of 4 |

This page intentionally left blank.

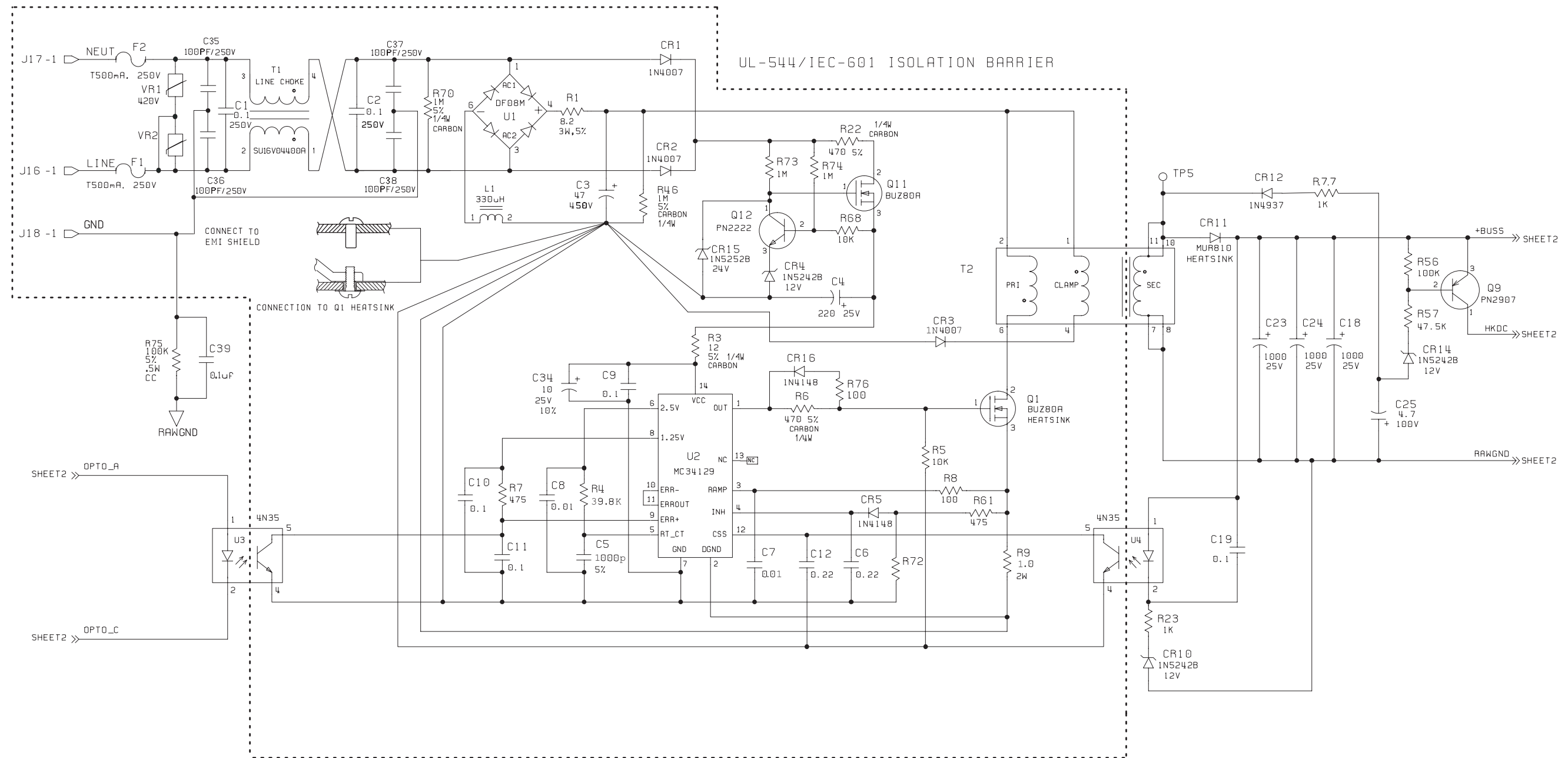

HOSPIRA, INC.
Figure 9-26. Power Supply PWA Schematic (XLM - International)

| | |
|---------------|--------------|
| DRAWING NO. | Rev. H |
| 249-05916-011 | Sheet 3 of 4 |

This page intentionally left blank.

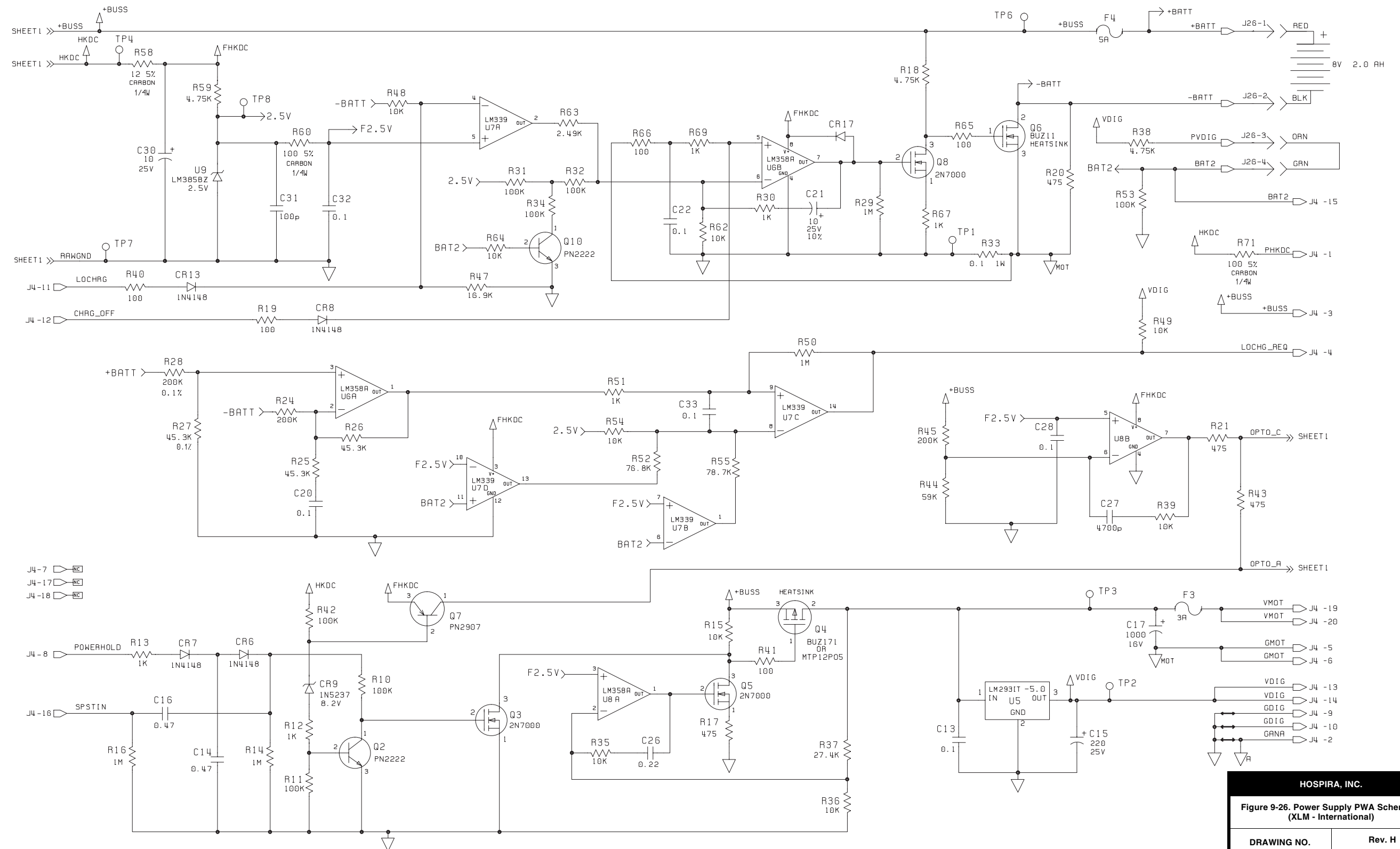

HOSPIRA, INC.
Figure 9-26. Power Supply PWA Schematic (XLM - International)

| | |
|---------------|--------------|
| DRAWING NO. | Rev. H |
| 249-05916-011 | Sheet 4 of 4 |

This page intentionally left blank.

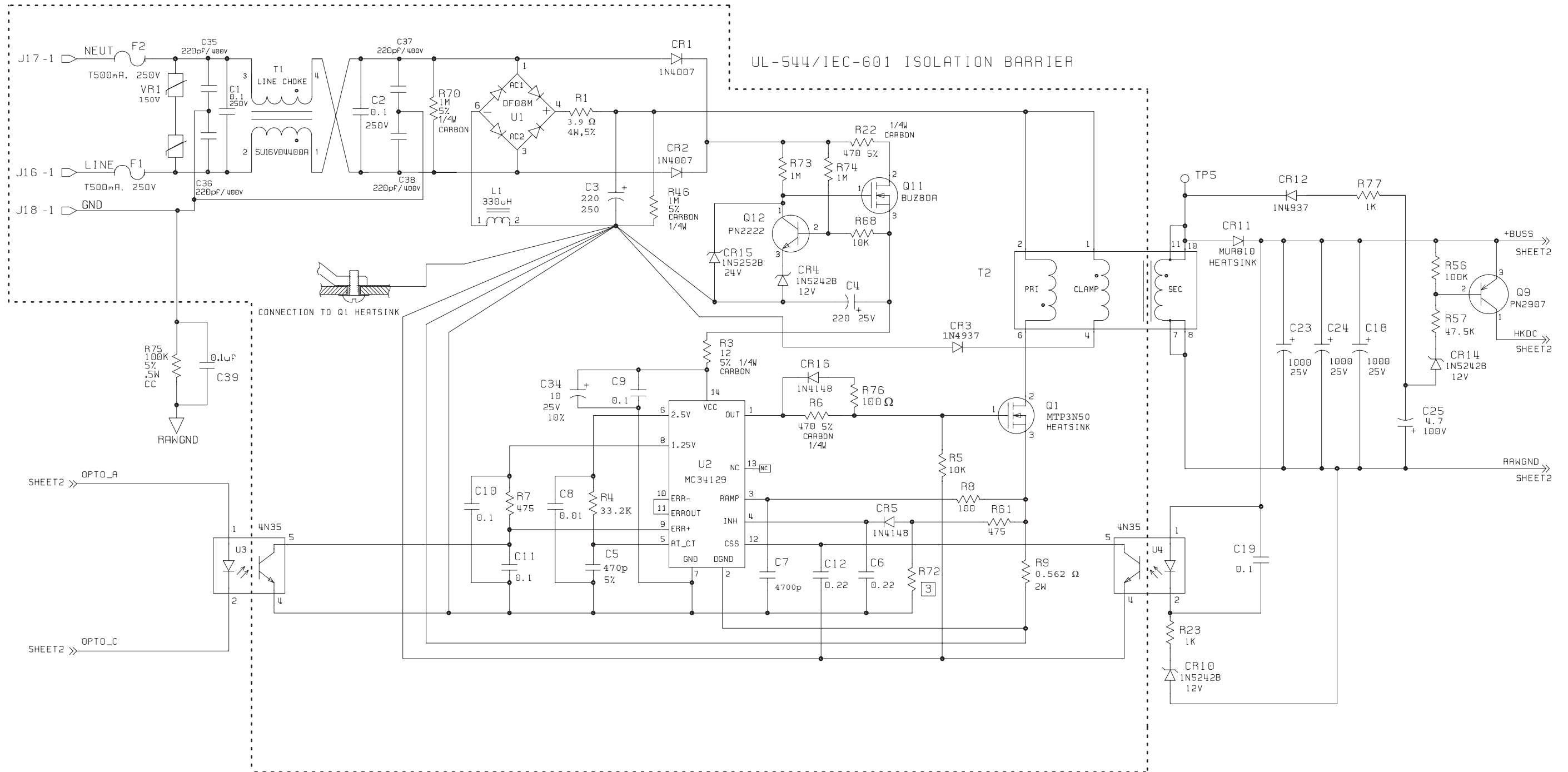

NOTES:

1. UNLESS OTHERWISE SPECIFIED:
ALL R'S IN OHMS, MF, 1%, 1/8W
ALL C'S IN μ F, 20%, 50V.
2. J26 PINS 3 AND 4 ARE SHORTED
AT BATTERY'S CONNECTOR WHEN
USING PANASONIC BATTERY.
3. CR17, R72 PROVISIONAL.

HOSPIRA, INC.

Figure 9-27. Power Supply PWA Schematic (XLM with DataPort)

| | |
|---------------|--------------|
| DRAWING NO. | Rev. F |
| 249-05916-006 | Sheet 1 of 4 |

This page intentionally left blank.

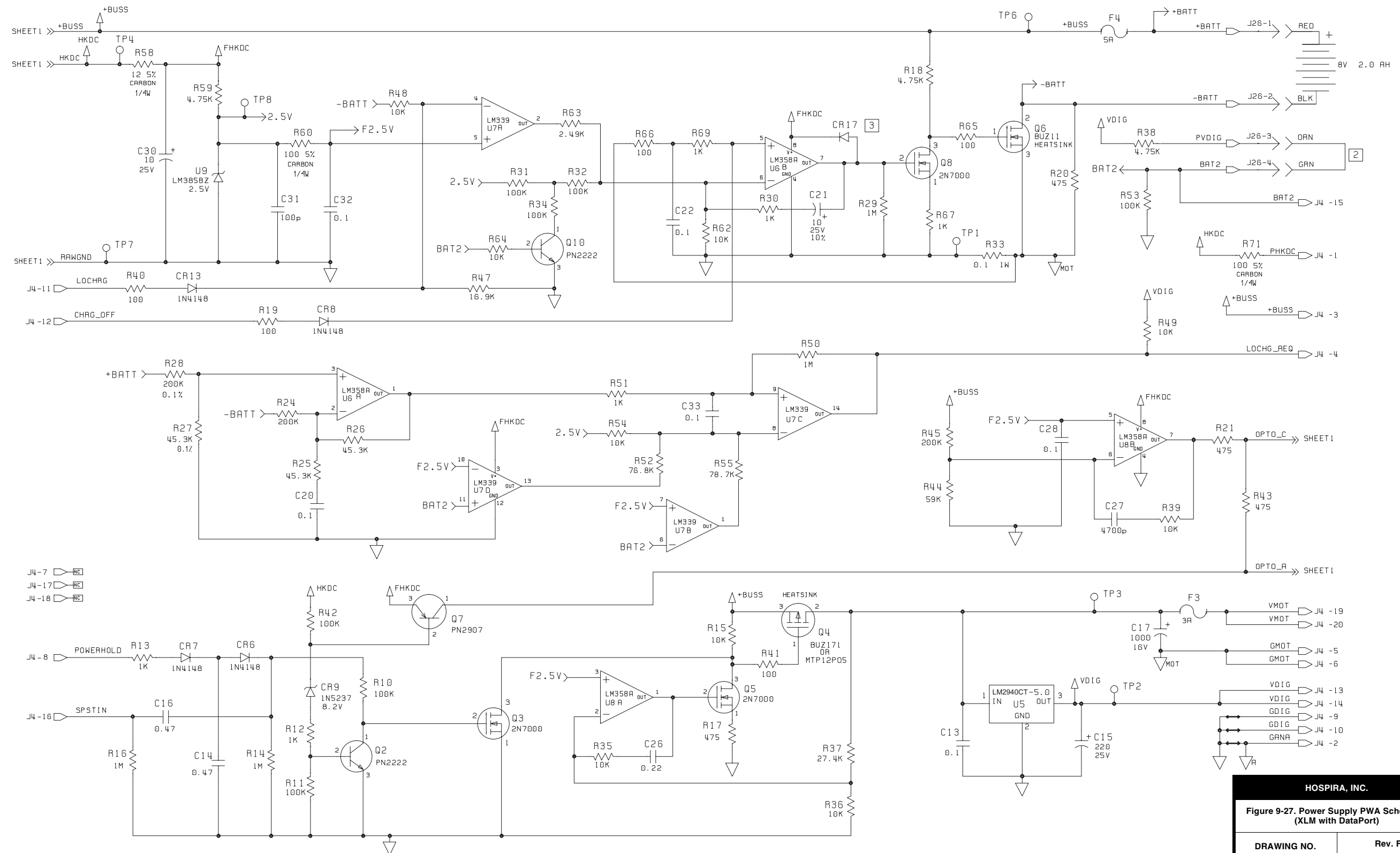

HOSPIRA, INC.
Figure 9-27. Power Supply PWA Schematic (XLM with DataPort)

| | |
|------------------------------|------------------------|
| DRAWING NO. 249-05916-006 | Rev. F Sheet 2 of 4 |
|------------------------------|------------------------|

This page intentionally left blank.

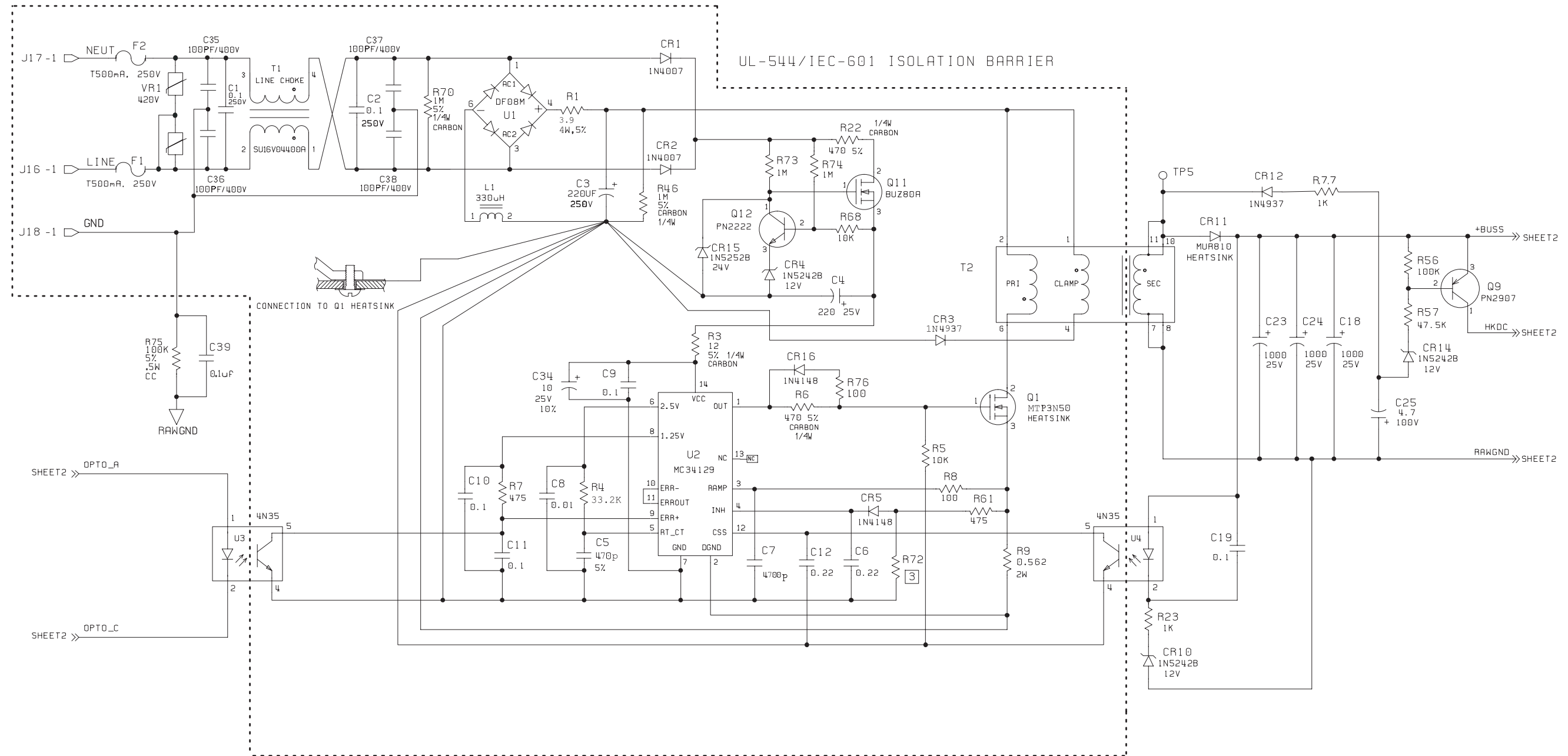

HOSPIRA, INC.
Figure 9-27. Power Supply PWA Schematic (XLM with DataPort)

| | |
|---------------|--------------|
| DRAWING NO. | Rev. G |
| 249-05916-012 | Sheet 3 of 4 |

This page intentionally left blank.

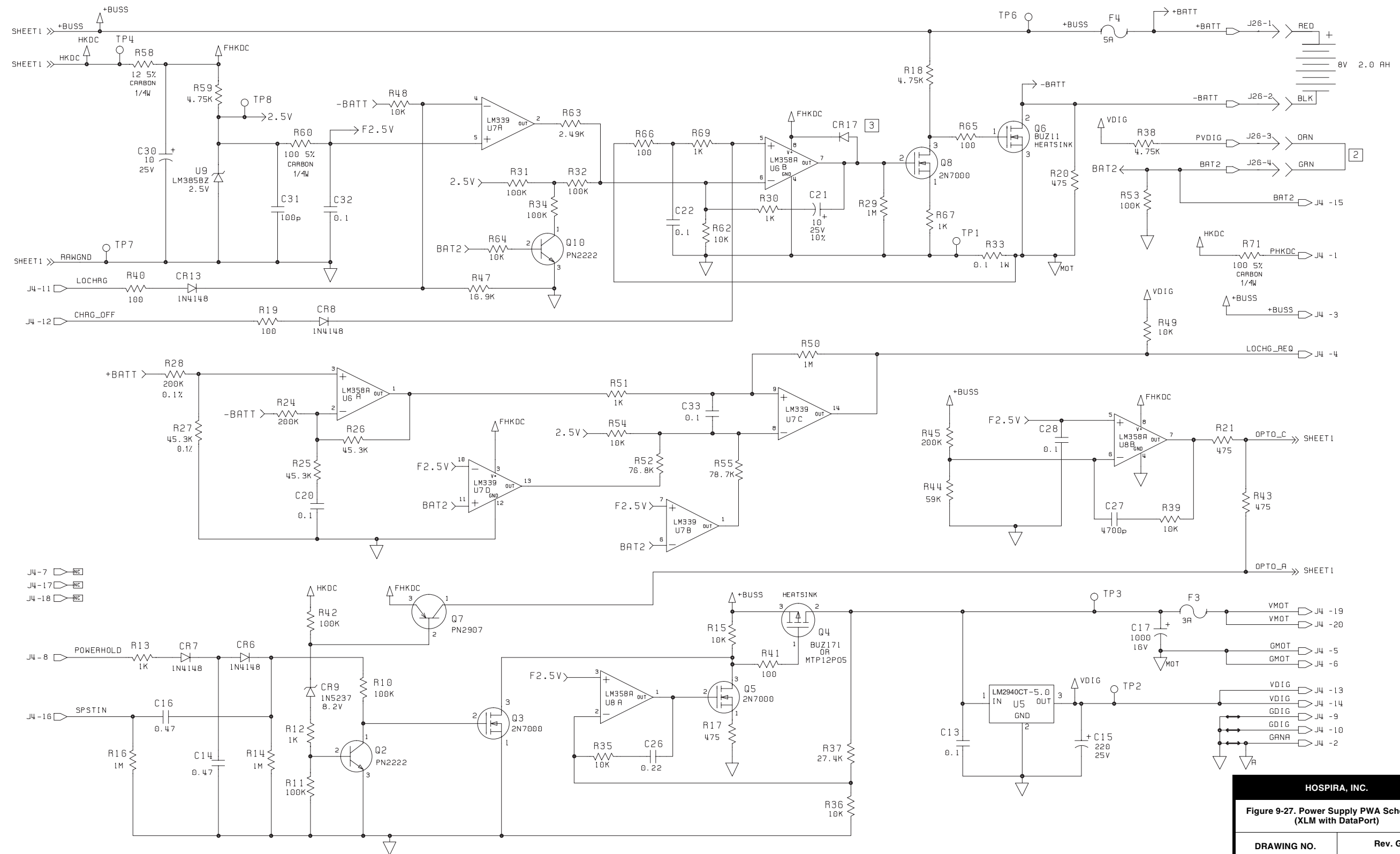

HOSPIRA, INC.
Figure 9-27. Power Supply PWA Schematic (XLM with DataPort)

| | |
|---------------|--------------|
| DRAWING NO. | Rev. G |
| 249-05916-012 | Sheet 4 of 4 |

This page intentionally left blank.

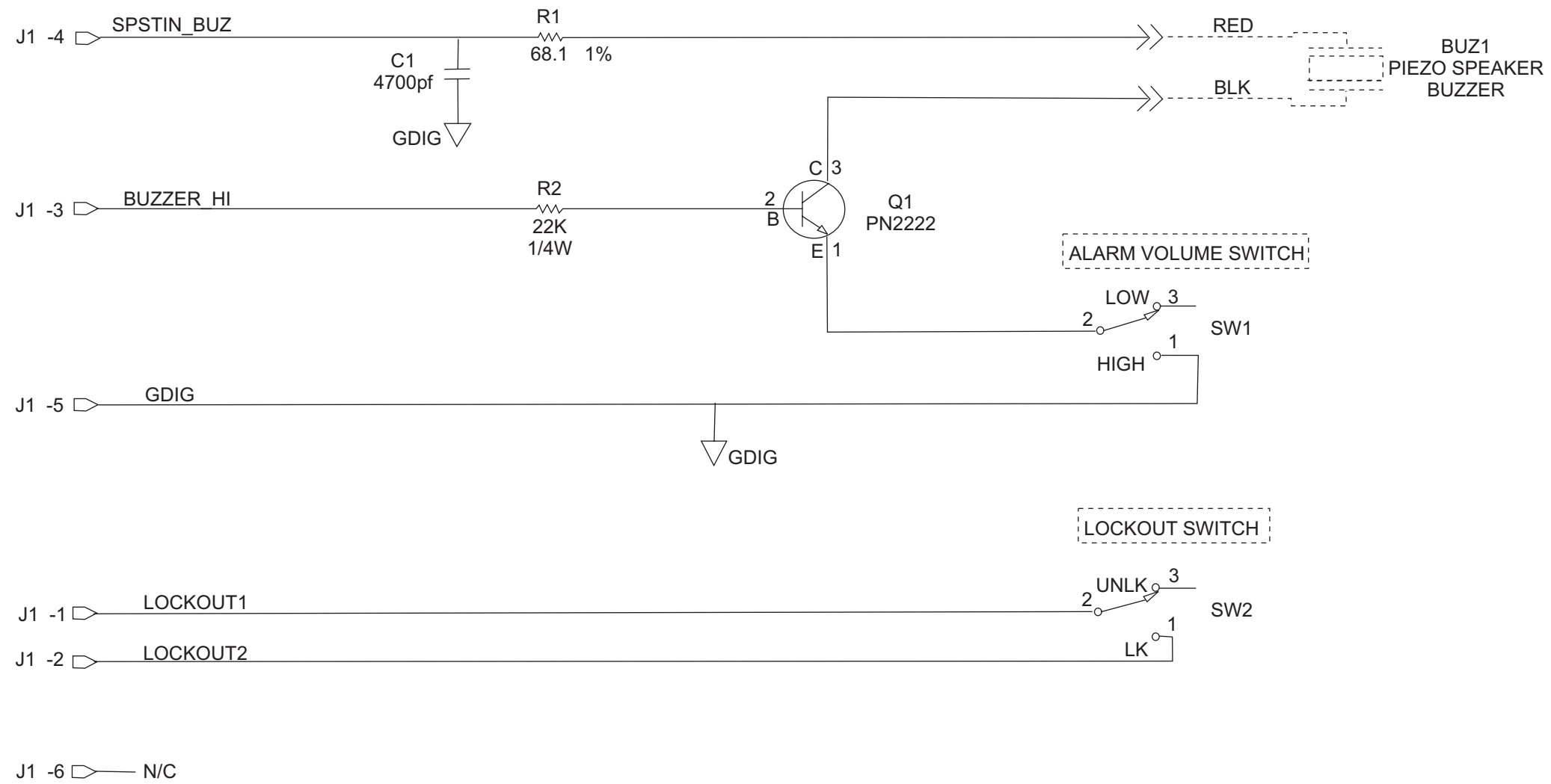

| | |
|-----------------------------------|--------------|
| HOSPIRA, INC. | |
| Figure 9-28. Buzzer PWA Schematic | |
| DRAWING NO. | Rev. B |
| 249-05903-002 | Sheet 1 of 1 |

This page intentionally left blank.

APPENDIX

CONSIDERATIONS FOR USE IN ELECTROMAGNETIC ENVIRONMENTS

 The LifeCare XLM with DataPort (outside of the United States) is intended for use in the electromagnetic environment specified in *Electromagnetic Emissions*, *Electromagnetic Immunity*, and *Electromagnetic Immunity for Life-Supporting Equipment and Systems*. The user of the device should assure that it is used only in the appropriate environment.

 **Note:** Do not connect DataPort when infusing.

ELECTROMAGNETIC EMISSIONS

Table A-1, Guidance and Manufacturer's Declaration - Electromagnetic Emissions details electromagnetic emissions compliance and guidance for XLM Series infusion systems

| Table A-1. Guidance and Manufacturer's Declaration - Electromagnetic Emissions | | |
|--|------------|---|
| Emissions Test | Compliance | Electromagnetic Enforcement - Guidance |
| RF Emissions CISPR 11 | Group 1 | The LifeCare XLM with DataPort uses RF energy only for its internal function. Therefore, its RF emissions are very low and are not likely to cause interference in nearby electronic equipment. |
| RF Emissions CISPR 11 | Class B | The LifeCare XLM with DataPort is suitable for use in all establishments, including domestic establishments and those directly connected to the public low voltage power supply network that supplies buildings used for domestic purposes. |
| Harmonic emissions IEC 61000-3-2 | Class B | |
| Voltage fluctuations/ flicker emissions IEC 61000-3-3 | Complies | |

ELECTROMAGNETIC IMMUNITY

Table A-2, Guidance and Manufacturer's Declaration - Electromagnetic Immunity details guidance for the electromagnetic environment for XL series infusion pumps

| Table A-2. Guidance and Manufacturer's Declaration - Electromagnetic Immunity | | | |
|--|--|--|---|
| Immunity Test | IEC 60601 Test Level | Compliance Level | Electromagnetic Environment Guidance |
| Electrostatic Discharge (ESD) IEC 61000-4-2 | ±6kV Contact ±8kV Air | ±8kV Contact ±15kV Air (See Note 2) | Floors should be wood, concrete or ceramic tile. If floors are covered with synthetic material, the relative humidity should be at least 30% |
| Electrical Fast Transient/Burst IEC 61000-4-4 | ±2kV for power supply lines ±1kV for input/output lines | ±2kV for power supply lines ±1kV for input/output lines | Mains power quality should be that of a typical commercial or hospital environment |
| Surge IEC 61000-4-5 | ±1kV differential mode ±2kV common mode | ±1kV differential mode ±2kV common mode | |
| Voltage dips, short interruptions and voltage variations on power supply input lines IEC 61000-4-11 | <5%U _r (>95% dip in U _r) for 0.5 cycle 40%U _r (60% dip in U _r) for 5 cycles 70%U _r (30% dip in U _r) for 25 cycles 5%U _r (>95% dip in U _r) for 5 seconds | <5%U _r (>95% dip in U _r) for 0.5 cycle 40%U _r (60% dip in U _r) for 5 cycles 70%U _r (30% dip in U _r) for 25 cycles 5%U _r (>95% dip in U _r) for 5 seconds | Mains power quality should be that of a typical commercial or hospital environment. If the user of the LifeCare XLM with DataPort requires continued operation during power mains interruptions, it is recommended that the LifeCare XLM with DataPort be powered from an uninterruptible AC Mains power supply or the battery. |
| Power Frequency (50/60 Hz) magnetic field IEC 61000-4-8 | 3A/m | 400A/m (See Note 3) | Power frequency magnetic fields should be at levels characteristic of a typical location in a typical commercial or hospital environment. |
| Note 1: U _r is the AC Mains voltage prior to application of the test level. | | | |
| Note 2: Compliance levels tested to IEC 60601-2-24 requirements, which are more stringent than IEC 61000-4-2. | | | |
| Note 3: Compliance levels tested to IEC 60601-2-24 requirements, which are more stringent than IEC 61000-4-8. | | | |

ELECTROMAGNETIC IMMUNITY FOR LIFE-SUPPORTING EQUIPMENT AND SYSTEMS

Table A-3, *Guidance and Manufacturer's Declaration - Electromagnetic Immunity for Life-Supporting Equipment and Systems*, provides guidance for use of the XLM with DataPort near communications equipment.

| Table A-3. Guidance and Manufacturer's Declaration - Electromagnetic Immunity for Life-Supporting Equipment and Systems | | | |
|---|---|---------------------|---|
| Immunity Test | IEC 60601 Test Level | Compliance Level | Electromagnetic Immunity-Guidance |
| | | | Portable and mobile RF communications equipment should be used no closer to any part of the LifeCare XLM with DataPort, including cables, than the recommended separation distance calculated from the equation applicable to the frequency of the transmitter. |
| Conducted RF IEC 61000-4-6 | 3 Vrms 150 kHz to 80 MHz outside ISM bands ^a | [V ₁] V | Recommended separation distance $d = \left[\frac{3,5}{V_1} \right] \sqrt{P}$ $d = \left[\frac{12}{V_2} \right] \sqrt{P}$ |
| | 10 Vrms 150 kHz to 80 MHz in ISM bands ^a | [V ₂] V | |

| Table A-3. Guidance and Manufacturer's Declaration - Electromagnetic Immunity for Life-Supporting Equipment and Systems | | | |
|---|-------------------------------|-----------------------|---|
| Immunity Test | IEC 60601 Test Level | Compliance Level | Electromagnetic Immunity-Guidance |
| Radiated RF IEC 61000-4-3 | 10V/m 80 MHz to 2.5 GHz | [E ₁] V/m | <p>Recommended separation distance:</p> $d = \left[\frac{12}{E_1} \right] \sqrt{P} \quad 80 \text{ MHz to } 800 \text{ MHz}$ $d = \left[\frac{23}{E_1} \right] \sqrt{P} \quad 800 \text{ MHz to } 2,5 \text{ GHz}$ <p>Where <i>P</i> is the maximum output power rating of the transmitter in watts (W) according to the transmitter manufacturer and <i>d</i> is the recommended separation distance in meters (m).^b</p> <p>Field strengths from fixed RF transmitters, as determined by an electromagnetic site survey,^c should be less than the compliance level in each frequency range.^d</p> <p>Interference may occur in the vicinity of equipment marked with the following symbol:</p>  |

Note: At 80 MHz and 800 MHz, the higher frequency range applies.

Note: These guidelines may not apply in all situations. Electromagnetic propagation is affected by absorption and reflection from structures, objects and people.

^a The ISM (industrial, scientific and medical) bands between 150 kHz and 80 MHz are 6.765 MHz to 6.795 MHz; 13.553 MHz to 13.567 MHz; 26.957 MHz to 27.283 MHz; and 40.660 MHz to 40.700 MHz.

^b The compliance levels in the ISM frequency bands between 150 kHz and 80 MHz and in the frequency range 80 MHz to 2.5 GHz are intended to decrease the likelihood that mobile/portable communications equipment could cause interference if it is inadvertently brought into patient areas. For this reason, an additional factor of 10/3 is used in calculating the recommended separation distance for transmitters in these frequency ranges.

^c Field strengths from fixed transmitters, such as base stations for radio (cellular and/or cordless) telephones and land mobile radios, amateur radio, AM and FM radio broadcast and TV broadcast cannot be predicted theoretically with accuracy. To assess the electromagnetic environment due to fixed RF transmitters, an electromagnetic site survey should be considered. If the measured field strength in the location in which the LifeCare XLM with DataPort is used exceeds the applicable RF compliance level above, the LifeCare XLM with DataPort should be observed to verify normal operation. If abnormal performance is observed, additional measures may be necessary, such as re-orienting or relocating the LifeCare XLM with DataPort.





^d Over the frequency range 150 kHz to 80 MHz, field strengths should be less than [V₁] V/m.

RECOMMENDED SEPARATION DISTANCES FOR COMMUNICATIONS EQUIPMENT

The LifeCare XLM with DataPort is intended for use in an electromagnetic environment in which radiated RF disturbances are controlled. The recommendations provided in *Table A-4, Recommended Separation Distances Between Portable and Mobile RF Communications Equipment and the LifeCare XLM with DataPort* help the user of the LifeCare XLM with DataPort to prevent electromagnetic interference by maintaining a minimum distance between portable and mobile RF communications equipment (transmitters) and the LifeCare XLM with DataPort, according to the maximum output power of the communications equipment

| Table A-4. Recommended Separation Distances Between Portable and Mobile RF Communications Equipment and the LifeCare XLM with DataPort | | | | |
|--|--|--|---|--|
| Rated Maximum Output Power of Transmitter (Watts) | Separation Distance According to Frequency of Transmitter (Meters) | | | |
| | 150 kHz to 80 MHz outside ISM bands $d = \left[\frac{3.5}{V_1} \right] \sqrt{P}$ | 150 kHz to 80 MHz in ISM bands $d = \left[\frac{12}{V_2} \right] \sqrt{P}$ | 80 MHz to 800 MHz $d = \left[\frac{12}{E_1} \right] \sqrt{P}$ | 800 MHz to 2.5 GHz $d = \left[\frac{23}{E_1} \right] \sqrt{P}$ |
| 0.01 | 0.035 | 0.12 | 0.12 | 0.23 |
| 0.1 | 0.11 | 0.38 | 0.38 | 0.73 |
| 1 | 0.35 | 1.2 | 1.2 | 2.3 |
| 10 | 1.1 | 3.8 | 3.8 | 7.3 |
| 100 | 3.5 | 12 | 12 | 23 |

For transmitters rated at a maximum output power not listed above, the recommended separation distance d in meters (m) can be determined using the equation applicable to the frequency of the transmitter, where p is the maximum output power rating of the transmitter in watts (W) according to the transmitter manufacturer.

-  **Note:** At 80MHz and 800 MHz, the separation distance for the higher frequency range applies.
-  **Note:** The ISM (industrial, scientific and medical) bands between 150 kHz and 80 MHz are 6.765 MHz to 6.695 MHz; 13.553 MHz to 13.567 MHz; 26.957 MHz to 27.283 MHz; and 40.660 MHz to 40.700 MHz.
-  **Note:** An additional factor of 10/3 is used in calculating the recommended separation distance for transmitters in the ISM frequency bands between 150 kHz and 80MHz and in the frequency range 80 MHz to 2.5 GHz to decrease the likelihood that mobile/portable communications equipment could cause interference if it is inadvertently brought into patient areas.
-  **Note:** These guidelines may not apply in all situations. Electromagnetic propagation is affected by absorption and reflection from structure, objects and people.
-  **Note:** $V_1=10V_{rms}$, $V_2=10 V_{rms}$, and $E_1=10 V/meter$.

This page intentionally left blank.

INDEX

A

- AC amplifier circuitry, [4-14](#)
- AC power cord replacement
 - (115V), [7-19](#)
 - (220V), [7-21](#)
- AC receptacle replacement (220V), [7-22](#)
- Acronyms and abbreviations, [1-6](#)
- Adhesive-backed insulator
 - replacement, [7-28](#)
- Alarm circuitry
 - XL, [4-8](#)
 - XLM, [4-8](#)
- Alarm history, [6-11](#)
- Alarm loudness and lock function tests (XLM), [5-9](#)
- Alarm loudness test (XL), [5-9](#)
- Alarm messages and error codes, [6-1](#)
 - Error codes requiring technical service, [6-6](#)
 - Operational alarm messages, [6-2](#)
 - Service mode, [6-11](#)
- Alarm power backup circuitry, [4-8](#)
- Artifacts, [1-8](#)

B

- Battery
 - Charger circuitry
 - 115 volt, [4-4](#)
 - 220 volt, [4-6](#)
 - Charger current test, [5-15](#)
 - Door pad replacement, [7-6](#)
 - Door replacement, [7-6](#)
 - Legend test, [5-10](#)
 - Operation overview, [5-14](#)
 - Replacement, [7-6](#)
 - Run time, [6-12](#)
- Bubble sensor PWA, [4-14](#)
 - Pin detector flex circuitry, [4-15](#)
 - Receiver circuitry, [4-15](#)
 - Schematic, [9-99](#)
 - Transmitter circuitry, [4-15](#)
- Buzzer PWA, [4-10](#)
 - Lockout switch, [4-11](#)
 - Replacement, [7-31](#)
 - Schematic, [9-137](#)

C

- Cassette, [4-16](#)
 - Door replacement, [7-36](#)
- Channel label, [6-13](#)
- Cleaning, [5-1](#)
 - Solutions, [5-2](#)
- Communication selection, [6-13](#)
- Component designators, [1-6](#)
- Considerations for use in electromagnetic environments, [A-1](#)
 - Electromagnetic emissions, [A-1](#)
 - Electromagnetic immunity for life-supporting equipment and systems, [A-3](#)
 - Electromagnetic immunity, [A-2](#)
 - Recommended separation distances for communications equipment, [A-5](#)
- Control knob
 - Circuitry (XL), [4-13](#)
 - Circuitry (XLM), [4-13](#)
 - Replacement, [7-13](#)
- Conventions, [1-5](#)

D

- DataPort connection and ground
 - continuity test, [5-16](#)
- DataPort/MCU cable replacement, [7-25](#)
- Delivery accuracy test, [5-12](#)
- Detent ring replacement, [7-13](#)
- Display circuitry
 - XL, [4-11](#)
 - XLM display PWA -003 and lower, [4-11](#)
 - XLM display PWA -004 and higher, [4-11](#)
- Display PWA, [4-11](#)
 - Control knob circuitry, [4-13](#)
 - Display circuitry (XL), [4-11](#)
 - Display circuitry (XLM display PWA -003 and lower), [4-11](#)
 - Display circuitry (XLM display PWA -004 and higher), [4-11](#)
 - EL panel driver circuitry, [4-12](#)
 - LED backlight panel and driver, [4-12](#)
 - Line power indicator circuitry, [4-12](#)
 - Replacement, [7-11](#)

Run indicator circuitry, [4-12](#)
 Schematic
 XL, [9-83](#)
 XLM, [9-85](#)
 Distal occlusion test, [5-11](#)
 Drawings, [9-1](#)

E

EEPROM circuitry, [4-14](#)
 Electrical safety test, [5-13](#)
 Electroluminescent panel driver circuitry (XL), [4-12](#)
 Electromagnetic
 Emissions, [A-1](#)
 Immunity for life-supporting equipment and systems, [A-3](#)
 Immunity, [A-2](#)
 Electronics overview, [4-2](#)
 Bubble sensor PWA, [4-14](#)
 Buzzer PWA, [4-10](#)
 Display PWA, [4-11](#)
 MCU PWA, [4-7](#)
 Power supply PWA, [4-2](#), [4-5](#)
 Sensor PWA, [4-13](#)
 EMI shield replacement, [7-22](#)
 Empty container/air-in-line alarm test, [5-12](#)
 End of performance verification test, [5-14](#)
 Equipment required, [5-4](#)
 Equipotential post replacement, [7-22](#), [7-23](#)
 Error codes requiring technical service, [6-6](#)

F

Free flow test, [5-10](#)
 Front enclosure assembly
 Component replacement, [7-10](#)
 Display PWA, [7-11](#)
 Front panel key replacement, [7-12](#)
 MCU/display cable, [7-11](#)
 Replacement, [7-9](#)
 Front panel
 Key replacement, [7-12](#)
 Label replacement, [7-14](#)
 Fuse replacement, [7-15](#)

G

General description, [4-1](#)
 Global product configurations, [1-2](#)

H

High volume audible alarm, [4-10](#)
 Hospira, [6-1](#)

I

Icons and english language equivalents, [5-5](#)
 Illustrated parts breakdown, [9-2](#), [9-7](#)
 Inlet/outlet valve subsystem, [4-20](#)
 Inspecting the infusion system, [5-1](#)
 Inspection, [1-9](#), [5-6](#)
 Instrument installation procedure, [1-8](#)
 Inspection, [1-9](#)
 Self test, [1-9](#)
 Unpacking, [1-8](#)
 Introduction, [1-1](#)

K

Keypad and control knob test, [5-8](#)
 Knob
 Detent replacement, [7-13](#)
 Gasket replacement, [7-13](#)
 Washer replacement, [7-13](#)

L

LED backlight panel and driver (XLM), [4-12](#)
 LifeCare AC receptacle
 Bracket replacement, [7-23](#)
 Gasket replacement, [7-23](#)
 Housing seal replacement, [7-23](#)
 Replacement, [7-23](#)
 LifeCare DataPort/MCU cable replacement, [7-27](#)
 Line power indicator circuitry, [4-12](#)
 Lockout switch, [4-11](#)

M

Main chassis assembly
 Component replacement, [7-32](#)
 Replacement, [7-9](#)
 Maintenance and service tests, [5-1](#)
 Battery operation overview, [5-14](#)
 DataPort connection and ground continuity test, [5-16](#)
 Nurse call function test, [5-18](#)

- Performance verification test, 5-4
 - Periodic maintenance inspection, 5-14
 - Routine maintenance, 5-1
 - MCU PWA, 4-7
 - Alarm circuitry (XL), 4-8
 - Alarm circuitry (XLM), 4-8
 - Alarm power backup circuitry, 4-8
 - Motor driver circuitry, 4-9
 - Nurse call alarm
 - (XLM with DataPort), 4-10
 - Pin detector circuitry, 4-9
 - Replacement, 7-33
 - Schematic (XL), 9-39
 - Schematic (XLM with DataPort), 9-47
 - Schematic, XLM, 9-43
 - Serial communication circuitry, 4-7
 - UART (XLM with Dataport), 4-9
 - Watchdog circuitry, 4-7
 - MCU/buzzer cable replacement, 7-31
 - MCU/display cable replacement, 7-11
 - Mechanical overview, 4-16
 - Cassette, 4-16
 - Mechanism assembly, 4-18
 - Mechanism assembly, 4-18
 - Inlet/outlet valve subsystem, 4-20
 - Motor and valve assemblies, 4-19
 - Plunger drive subsystem, 4-20
 - Primary/secondary valve subsystem, 4-19
 - Replacement, 7-35
 - Mechanism shield replacement, 7-36
 - Motor and valve assemblies, 4-19
 - Motor driver circuitry, 4-9
- N**
- Nurse call alarm
 - (XLM with DataPort), 4-10
 - Nurse call function test, 5-18
- O**
- Open door alarm test, 5-9
 - Opener handle assembly replacement, 7-41
 - Operational alarm messages, 6-2
 - Opto interrupter circuitry, 4-14
- P**
- Parameter programming (XLM with DataPort), 6-12
 - Channel label, 6-13
 - Communication selection, 6-13
 - Soft ID, 6-13
 - Performance verification test, 5-4
 - Alarm loudness and lock function (XLM), 5-9
 - Alarm loudness test (XL), 5-9
 - Battery legend test, 5-10
 - Delivery accuracy test, 5-12
 - Distal occlusion test, 5-11
 - Electrical safety test, 5-13
 - Empty container/air-in-line alarm test, 5-12
 - End of performance verification test, 5-14
 - Equipment required, 5-4
 - Free flow test, 5-10
 - Icons and english language equivalents, 5-5
 - Inspection, 5-6
 - Keypad and control knob test, 5-8
 - Open door alarm test, 5-9
 - Proximal occlusion test, 5-10
 - Self test, 5-7
 - Test setup, 5-6
 - Periodic maintenance inspection, 5-14
 - Pin detector
 - Circuitry, 4-9
 - Flex circuitry, 4-15
 - Schematic, 9-107
 - Plum XL block diagram, 9-37
 - Plunger drive subsystem, 4-20
 - Pole clamp
 - Backing plate replacement, 7-28
 - Extrusion replacement, 7-28
 - Shaft tip replacement, 7-30
 - Shaft/knob assembly replacement, 7-30
 - Power supply PWA
 - 115 volt, 4-2
 - 220 volt, 4-5
 - Schematic
 - XL Domestic, 9-109
 - XL International, 9-113
 - XLM Domestic, 9-117
 - XLM International, 9-121
 - XLM with DataPort, 9-129
 - Power supply PWA replacement, 7-17
 - Power supply PWA,
 - Battery charger circuitry, 4-4, 4-6
 - Switcher circuitry, 4-2, 4-5
 - Voltage regulator circuitry, 4-3, 4-6
 - Pressure amplifier/filter circuitry, 4-13
 - Primary/secondary valve subsystem, 4-19
 - Procedures
 - Instrument installation, 1-8
 - Troubleshooting, 6-14
 - Proximal occlusion test, 5-10

R

- Rear enclosure assembly
 - Component replacement, [7-14](#)
 - Replacement, [7-9](#)
- Receiver circuitry, [4-15](#)
- Recommended separation distances for communications equipment, [A-5](#)
- Replaceable parts and repairs, [7-1](#)
- Replacement procedures, [7-3](#)
 - AC power cord (115V), [7-19](#)
 - AC power cord (220 volt), [7-21](#)
 - AC receptacle, [7-22](#)
 - Battery door pad, [7-6](#)
 - Battery door, [7-6](#)
 - Battery, [7-6](#)
 - Buzzer PWA, [7-31](#)
 - Cassette door, [7-36](#)
 - Control knob, [7-13](#)
 - DataPort/MCU cable replacement, [7-25](#)
 - EMI shield, [7-22](#)
 - Equipotential post, [7-22](#)
 - Front enclosure assembly components, [7-10](#)
 - Front enclosure assembly, [7-9](#)
 - Front panel label, [7-14](#)
 - Fuse, [7-15](#)
 - LifeCare AC receptacle, [7-23](#)
 - LifeCare DataPort/MCU cable, [7-27](#)
 - Main chassis assembly components, [7-32](#)
 - Main chassis assembly, [7-9](#)
 - MCU PWA, [7-33](#)
 - MCU/buzzer cable replacement, [7-31](#)
 - Mechanism assembly, [7-35](#)
 - Mechanism shield replacement, [7-36](#)
 - Opener handle assembly, [7-41](#)
 - Pole clamp components, [7-28](#)
 - Pole clamp shaft tip, [7-30](#)
 - Pole clamp shaft/knob assembly, [7-30](#)
 - Power supply PWA, [7-17](#)
 - Rear enclosure assembly components, [7-14](#)
 - Rear enclosure assembly, [7-9](#)
 - Required tools and materials, [7-3](#)
 - Rubber foot pad replacement, [7-4](#)
 - Safety and equipment precautions, [7-3](#)
 - Sensor/MCU cable assembly, [7-33](#)
 - Separating the front, rear, and main chassis assemblies, [7-7](#)
 - Strain relief bushing, [7-19](#)
 - Velcro retainer strap, [7-19](#)
- Required tools and materials, [7-3](#)
- Routine maintenance, [5-1](#)
 - Cleaning, [5-1](#)

- Inspecting the infusion system, [5-1](#)
- Sanitizing the infusion system, [5-2](#)
- Rubber foot pad replacement, [7-4](#)
- Run indicator circuitry, [4-12](#)
- Run time, [6-12](#)

S

- Safety and equipment precautions, [7-3](#)
- Sanitizing the infusion system, [5-2](#)
- Schematics
 - Bubble sensor PWA, [9-99](#)
 - Buzzer PWA, [9-137](#)
 - Display PWA (XL), [9-83](#)
 - Display PWA (XLM), [9-85](#)
 - MCU PWA (XL), [9-39](#)
 - MCU PWA (XLM with DataPort), [9-47](#)
 - MCU PWA (XLM), [9-43](#)
 - Pin detector flex circuit, [9-107](#)
 - Plum XL block diagram, [9-37](#)
 - Power supply PWA
 - XL Domestic, [9-109](#)
 - XL International, [9-113](#)
 - XLM Domestic, [9-117](#)
 - XLM International, [9-121](#)
 - XLM with DataPort, [9-129](#)
- Scope, [1-1](#)
- Self test, [1-9](#), [5-7](#)
- Sensor PWA, [4-13](#)
 - AC amplifier circuitry, [4-14](#)
 - EEPROM Circuitry, [4-14](#)
 - Opto interrupter circuitry, [4-14](#)
 - Pressure amplifier/filter circuitry, [4-13](#)
 - Voltage reference circuitry, [4-14](#)
- Sensor/MCU cable assembly replacement, [7-33](#)
- Separating the front, rear, and main chassis assemblies, [7-7](#)
- Serial communication circuitry, [4-7](#)
- Service mode, [6-11](#)
 - Alarm history, [6-11](#)
 - Battery run time, [6-12](#)
 - Parameter programming, [6-12](#)
 - Run time, [6-12](#)
 - Software revision number, [6-12](#)
- Snap retainer replacement, [7-13](#)
- Soft ID, [6-13](#)
- Software revision number, [6-12](#)
- Specifications, [8-1](#)
 - LifeCare XL and XLM, [8-2](#)
 - Plum XL and XLM, [8-1](#)
- Strain relief bushing replacement, [7-19](#)

Switcher circuitry
 115 volt, [4-2](#)
 220 volt, [4-5](#)
 System operating manual, [3-1](#)

T

Technical assistance, [6-1](#)
 Test setup, [5-6](#)
 Tests
 Alarm loudness (XL), [5-9](#)
 Alarm loudness and lock function (XLM), [5-9](#)
 Battery charger current, [5-15](#)
 Battery legend, [5-10](#)
 DataPort connection and ground continuity, [5-16](#)
 Delivery accuracy, [5-12](#)
 Distal occlusion, [5-11](#)
 Electrical safety, [5-13](#)
 Empty container/air-in-line alarm, [5-12](#)
 Free flow, [5-10](#)
 Keypad and control knob, [5-8](#)
 Nurse call function, [5-18](#)
 Open door alarm, [5-9](#)
 Performance verification, [5-4](#)
 Proximal occlusion, [5-10](#)
 Self, [1-9](#), [5-7](#)
 Theory of operation, [4-1](#)
 Electronics overview, [4-2](#)
 General description, [4-1](#)
 Mechanical overview, [4-16](#)
 Transmitter circuitry, [4-15](#)
 Troubleshooting, [6-1](#)
 Alarm messages and error codes, [6-1](#)
 Procedures, [6-14](#)
 Technical assistance, [6-1](#)

U

Universal Asynchronous Receiver/
 Transmitter, [4-9](#)
 Unpacking, [1-8](#)
 User qualification, [1-7](#)

V

Velcro retainer strap, [7-19](#)
 Voltage reference circuitry, [4-14](#)
 Voltage regulator circuitry
 115 volt, [4-3](#)
 220 volt, [4-6](#)

W

Warranty, [2-1](#)
 Watchdog circuitry, [4-7](#)

This page intentionally left blank.

For technical assistance, product return authorization, and to order parts, accessories, or manuals within the United States, [contact Hospira](#) Technical Support Operations.

1-800-241-4002

For additional technical assistance, technical training, and product information, visit the website at: www.hospira.com

Send all authorized, prepaid returns within the United States to the following address:

**Hospira, Inc.
Technical Support Operations
755 Jarvis Drive
Morgan Hill, California 95037**

For technical assistance and services outside the United States, contact the local Hospira sales office.

CAUTION: Federal (USA) law restricts this device to sale by or on the order of a physician or other licensed practitioner.

WARNING: POSSIBLE EXPLOSION HAZARD EXISTS IF THE COMPUTER IS USED IN THE PRESENCE OF FLAMMABLE ANESTHETICS.

PATENTS

Covered by one or more of the following U.S. patents: 5,277,191; 5,261,411; 5,285,796; 5,217,019; 5,341,476

Vesphene Iise, Manu-Klenz, Coverage HB, Dispatch, Precise, Formula C, Sporicidin, Fluke, Fluke Biomedical, X-acto, and Velcro are not trademarks of Hospira, Inc.



Type CF

Equipment providing an adequate degree of protection against electrical shock and suitable for application to patient

IPX1

Drip Proof Medical Equipment

Class 1

Mains supply equipment using protective earth



Authorized Representative:
Hospira
Donegal Town
Co. Donegal, Ireland



CSA is a registered trademark of the Canadian Standards Association. The use of NRTL/C adjacent to the CSA mark indicates that the product has been certified by CSA to U.S. and Canadian standards. CSA has been accredited by the U.S. Occupational Safety and Health Administration (OSHA), as a Nationally Recognized Test Laboratory (NRTL).

Printed in USA

Hospira, Inc. □ Lake Forest □ Illinois 60045 USA